

New Energy Technologies

Magazine

Scientific news on advanced propulsion systems for aerospace industry and new energy technologies

Issue #1 (16) January-March 2004

CONTENTS

Torsion Technologies Are Technologies of The XXI st Century, A.E.Akimov, Russia	2
The Antigravitational Platform, Review	12
Potapov's Vortex Heat Generator, Yu.S.Potapov	15
Fuelless Air Combustion, Alexander V. Frolov	17
A Free Energy Generator, Zoltan Losonc, Hungary	19
Society for Development of Free Energy Technologies (GFE, Germany)	25
The "Confined B-field" Homopolar Dynamotor, J. Guala-Valverde, and Pedro Mazzoni, Argentina	28
A Hydroelectric Heat Generator, F.M. Kanarev, Russia	34
Conversion of Environmental Energy, B.M.Kondrashov, Russia	39
The World of Free Energy, Peter Lindemann, USA	46
The LUTEC Free Energy Generator, Australia	54
Pulsed Direct Current for Light Circuits, Gary Magratten, USA	56
Patent Applications on Thermo-Gravitation, Russia	61
An Electrogravitational Engine	62
"BREEZE 5000" Wind Energy Installation, T.A Pungas, Russia	63
Silicon-Based Power Engineering	65
A Method of Extraction (Restitution) of Energy, V.F Markelov, Russia	66
Asymmetric Capacitors, Alexander V. Frolov	73
Force on An Asymmetric Capacitor, Chris Fazi, CIIIA	75
The Working Principle of Frolov's T-Capacitor, Zoltan Losonc, Hungary	76
A Precession Free Energy Generator, V.I. Bogomolov, Russia	83
On The Way To A New Astronautics, A.V. Perfiliev, Russia	89
An Energy Converter, Review	91
CD "New Energy Technologies"	92
What Ever Happened To Black Light Power? Patrick Bailey, USA	95
The subscriber's page	96

Publisher: Faraday Lab Ltd

4 issues in 2004

Editor-in-Chief Alexander V. Frolov, **Scientific Advisor** Kirill P. Butusov,
Designer Elena I. Ostrova, **Translator** Nickolay I. Ovtcharenko

Correspondence Address: Lev Tolstoy Str., 7 St-Petersburg 197376 Russia,
Tel/fax : 7 (812) 380-3844, net@faraday.ru, http://www.faraday.ru

Subscription: \$46 (printed copy), \$26 (CD with PDF files of all the back issues). Air mail delivery included

Printed in Russia Copyright © 2004 by Faraday Lab Ltd.

Circulation: 500 printed copies

Information reported in New Energy Technologies magazine is not necessary endorsed by the publisher or staff.
In many cases information received cannot be verified, though we try to report the news as accurately as possible.

Torsion Technologies Are Technologies Of The XXIst Century

Director General of the International Institute of Theoretical and Applied Physics of the Russian Academy of Natural Sciences,
A. AKIMOV, Ph.D.

Note: the article is published with minor abridgements.

Over the past three hundred years scientists have been aware of two universal long-range types of field: gravitational and electromagnetic fields. The significance of universal long-range fields can be easily manifested by the example of electromagnetic fields. The twentieth century clearly showed that it is difficult to find any technical, scientific or household problem which could not be solved by means of electromagnetism. The fields of its implementation include the electric power industry, electric transport, radio communication, computers, navigation, etc. Take a look at your apartment and you are sure to see an electromagnetic device, be it a refrigerator, a TV, a vacuum cleaner, a microwave oven and so on. When a patient enters a physiotherapy room, he is greeted by a lot of equipment, most of which are electromagnetic instruments. Not a single universal long-range field that can find such an impressive list of practical applications as electromagnetism has been discovered for the last three hundred years.

At the beginning of the twentieth century a French scientist, E. Cartan, postulated the existence of torsion fields in nature, i.e. fields generated by the angular momentum of rotation [1]. Before spin was discovered, the nature of the torsion field had been explained by the rotation of huge objects. Within the framework of such an approach, torsion fields are viewed as a manifes-

tation of a gravitational field of huge rotating objects [2]. Later on, when spin, a quantum analog of the angular momentum of rotation, was discovered, it became clear that torsion fields, unlike electromagnetic fields generated by charges and gravitational fields generated by mass, at quantum level are generated by spin. From this standpoint, torsion fields can be viewed as independent physical objects similar to electromagnetic and gravitational fields.

By the mid-1970s, the theoretical research into torsion fields had resulted in the appearance of an independent line of theoretical physics called the Einstein-Cartan theory. Practically all the experts working within the framework of the Einstein-Cartan Theory postulate that torsion fields are but a specific manifestation of gravitational fields. The most prominent of these experts are E. Fradkin, D. Gitman, V. Ponomarev and U. Obukhov from Russia, R. Hammond from the USA, R. Hehl from Germany, V. De Sabbata and C. Sivaram from Italy, M. Karmeli from Israel and others.

The Einstein-Cartan Theory has remained a theoretical discipline that has not found practical application since it proved that torsion fields are weak and cannot cause the creation of visible phenomena or effects. It was not until the 80s, that G. Shipov created the Theory of The Physical Vacuum (TPV). It proved the Einstein-Cartan theory to be a phenomenological theory, primarily due to its relation to the phenomenological nature of Cartan's geometry. A fundamental theory of torsion fields based on Ricci's geometry was developed within the framework of the Theory of The Physical Vacuum. The theory

of torsion fields in TPV does not impose any restrictions on the constant of spin-torsion interactions, i.e. torsion fields can manifest themselves intensively. It is worth noting that even the Einstein-Cartan Theory does not impose any restrictions on the constant of spin-torsion interactions for dynamic torsion (for radiating torsion sources). This does not prove that torsion fields have strong manifestations. The importance of this lies in the fact that the theory does not demand that the constant of spin-torsion interactions necessarily be small. In this case, the answer to the question as to whether this constant is small or big and, consequently, whether possible effects are strong or weak, can be obtained only by means of direct experimental measurements.

What is the basic interpretation of the Physical Vacuum? Imagine a limited volume of space from which the air is removed. Traditionally, we would say there is nothing there, which means that there is a vacuum. However, according to modern understanding, this space represents a technical vacuum since, physically speaking, it is not totally empty. Let us imagine now that we have managed to remove all the fundamental particles from this space and to screen it so that no particles from outside can get in. But even in this case, from the point of view of modern physics, it is impossible to assert that the space is empty. So-called virtual electron-positron pairs can appear at random locations of this volume of space. Material objects, which are electron-positron pairs, cannot appear from nowhere. They can only be produced by a substance of some sort, and if we do not register it directly in the specified space, from which the virtual pairs arise, this will indicate that we are dealing with a specific substance that cannot be observed under usual conditions. This specific substance was called the Physical Vacuum. Apart from producing electron-positron pairs, the Physical Vacuum manifests itself in a number of experimentally observed phenomena. The Physical Vacuum is known to manifest itself in the so-called Lamb Shift in a hyperfine structure of hydrogen atom radiation, determining the so-called Kazemir Effect.

The standard interpretation describes the Physical Vacuum as a complex quantum dynamic object, which manifests itself through fluctuations. Such an approach of scientific description of the Physical Vacuum derives from the concept of S. Winberg, A. Salam and S. Glashow. G. Shipov's Theory of the Physical Vacuum is based on rigorous fundamental postulates. This theory provides an ana-

lytical description of the Physical Vacuum on the basis of three vacuum equations: the equation of Einstein, the equation of Geisenberg and the equation of Young-Mills, representing the structural equations of Weitzenbock's geometry. G. Shipov's Theory of the Physical Vacuum has allowed us to reconsider the structure of creation. Reality, of which we are an integral part, is divided into seven hierarchical levels.

The topmost level, the Absolute Nothing, is a level which does not have any strict analytical description within the framework of the Theory of the Physical Vacuum. The problem will need to be solved by future theories. **However, there are grounds to believe that this level of reality contains information defining the necessity of generating a subsequent level of reality** to determine the way (laws) this generation should take place, which, in its turn, determines the properties of still another level of reality. Shipov called this next level of reality a "primary torsion field". **A primary torsion field is a special form of existence of substance, representing quantum vortices that do not possess and transmit energy. These quantum vortices interact on the level of information.** If there is no quantum vortice interaction energy in the primary torsion field, the perturbation transfer rate in the medium of this level can only equal infinity. The primary torsion field should contain information defining the necessity of generating the subsequent level of reality, which determines the way (laws) this generation should take place, which, in its turn, determines the properties of still another level of reality. This level of reality is known to modern physics as the Physical Vacuum. The Physical Vacuum might have a lot of components and various structural elements. As well as the primary torsion field, it contains ring vortex structures that do not transfer energy. Perturbation propagates instantly in the Physical Vacuum, i.e. its speed equals infinity. The properties of the Physical Vacuum must include information, defining the mechanism of originating virtual pairs of specific rather than somewhat random particles and antiparticles. **Particles that originate from the Physical Vacuum constitute the following level of the hierarchy of reality, i.e. plasma.** Properties of such particles as electrons, protons and neutrons, coupled with those of the Physical Vacuum, with which they interact, determine the appearance of specific rather than random atoms generated from the specified particles. These atoms and the molecules they make up constitute the following three levels

of reality, depending on the state of the phase – gases, fluids and solids. Shipov called the four lower levels of this seven-leveled reality structure “Objective Physics”, which is a subject of traditional schools of Physics. The upper two levels were called “Subjective Physics”. A number of theoretical experimental results testify to the fact that these two levels, together with the level of the Physical Vacuum, are responsible not only for many physical phenomena and processes, but also play a role of primary importance in human consciousness. **It is possible that the Absolute Nothing is a level connected with the global manifestation of the Spirit as a cosmic factor.** The level of the Spirit needs to be creative and strong-willed. The inevitability of the existence of the creative nature of the Spirit is determined by the fact that the whole vertical structure and properties of all the horizontal levels need to be first “formulated” at the level of Absolute Nothing. The inevitability of the volitional nature of the Spirit of the Absolute Nothing level is determined by the fact that there must have been an Impulse that started the mechanism of creation of the above-mentioned reality levels. **In the end, it turned out that the Theory of the Physical Vacuum, as well as the physical models constructed, not only gives ground to set up a Physics of Consciousness, but also allows us to approach physical representations of the role of the Spirit.**

Phenomenological models of the Physical Vacuum appeared in Russia in the early 1980s and later turned out to correspond to the conclusions of the Theory of the Physical Vacuum. The fact that these models did not contradict to known experimental results was also of great importance.

When models of the Physical Vacuum were created it was considered expedient to return to the electron-positron model of P. Dirac in its changed interpretation. This approach may be considered justified if it allows us to formulate conclusions that do not follow directly from standard notions.

At the same time, by considering the vacuum as a state without particles, and, proceeding from the model of the classical spin, which Ya. Frenkel and I. Ternov consider to be a ring undulatory package (a circulating energy flow, according to Belinfante’s terminology [6]), we shall view the vacuum as a system consisting of ring undulatory packages corresponding to electrons and positrons, rather than electron-positron pairs carrying information about the properties of these particles.

It follows from the above suggestions that the true electroneutrality of such an electron-positron vacuum will only be possible if the ring undulatory packages of electrons and positrons are enclosed one into another, as you see it in Fig. 1A. If the spins of these enclosed ring packages are opposite each other, such a system will be self-compensated not only with respect to charges, but also with respect to the classical spin and magnetic moment. The system comprising the enclosed ring undulatory packages, as is shown in Fig. 1A, will be referred to as a **fiton**.

Let us consider the most practically important cases of Physical Vacuum perturbation by different external sources within the framework of the proposed model. This may help demonstrate the feasibility of the suggested approach.

1. Let the charge (q) be the perturbation source. If the vacuum has a fiton structure, the activity of the charge will be expressed in the charge polarization of the Physical Vacuum, as is shown in Fig. 1C. This case is well known in quantum electrodynamics. In particular, the Lamb Shift is traditionally explained through charge polarization of the electron-positron Physical Vacuum.
2. Let the mass (m) be the perturbation source. Unlike the previous case, where we face a well-known situation, we will come up with a hypothetical supposition here. Perturbation of the Physical Vacuum by the mass m will be expressed in symmetric oscillations of the fiton elements along the axis on the center of the object of perturbation, as is shown in Fig. 1D. Such a state of the Physical Vacuum can be characterized as a gravitational field (G-field).
If the mechanism of gravitation really relates to longitudinal spin polarization of the Physical Vacuum, we will have to admit then that the nature of gravitation bans precludes existence of antigravity.
3. Let the classical spin be the perturbation source. Presumably, the action of the classical spin on the Physical Vacuum will consist in the following. If the source has a spin oriented in the manner shown in Fig. 1e, spins of fitons that coincide with the orientation of the source’s spin retain their orientation. Spins of fitons that are opposite to the source’s spin undergo an inversion enforced by the activity of the source. As a result, the Physical Vacuum will adopt a state of transverse spin polarization. This polarization state

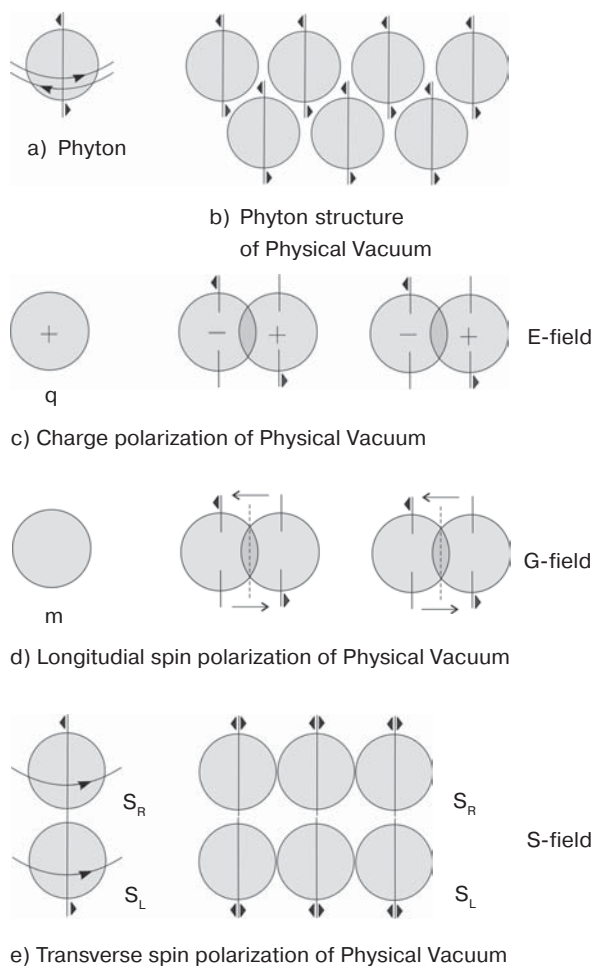

Fig. 1. Diagrams of polarization states of the Physical Vacuum

can be interpreted as a spin field (S-field), a field generated by the classical spin, i.e. a torsion field. The above approach tallies with notions of torsion fields as a condensate of fermion pairs.

The S_R and S_L polarization spin states contradict Pauli's exclusion. However, according to Academician M. Makarov' concept [7], fundamental physical laws can alternate at densities close to Planck's densities. Rejection of Pauli's exclusion in a specific material medium, such as the Physical Vacuum, is permissible, and probably to no less extent than it is the case with the concept of quarks.

According to the above approach, we can state that the uniform medium, the Physical Vacuum, can be in a different phase, or, to be more precise, polarization states, i.e. EGS states. This medium in the state of charge polarization manifests itself

as an electromagnetic field (E). The same medium in the state of spin longitudinal polarization manifests itself as a gravitational field (G). Finally, the Physical Vacuum in the state of spin transverse polarization manifests itself as a spin (torsion) field (S). Thus, EGS-fields correspond to the EGS-polarization states of the Physical Vacuum.

In the early 1980s, A. Akimov predicted and experimentally confirmed the existence of a special class of torsion fields – electrotorsion fields [9]. In the mid-1990s, the author of the Theory of the Physical Vacuum, G. Shipov, gave a fundamentally rigorous substantiation of electrotorsion fields [3].

The model of polarization states of the Physical Vacuum has allowed us to establish an important circumstance. It has already been reported that a torsion field can be registered in cases when the Physical Vacuum adopts a state of spin transverse polarization. However, we can formulate a more general approach based on synergetic criteria. Presumably, a torsion field can be registered in all cases when the Physical Vacuum is in a non-equilibrium spin state.

It is clear that the charge scission of fitons also causes spin spatial scission in the process of charge polarization of the Physical Vacuum, as you see in Fig. 1c. As a result, the spins appear to be non-compensated, which is an equivalent of the torsion component in an electromagnetic field. Gravitational and torsion fields manifest themselves “purely”, whereas electromagnetic fields always contain a torsion component, which is an important fundamental fact. A torsion field can be observed both in an electrostatic field and in electromagnetic radiation.

The inability to understand this has frequently resulted to that many tried to explain phenomena generated by electromagnetic sources by means of electromagnetic phenomena. In this connection, it is necessary to mention the works of explorer Zen Kanzhen, inventor Hideo Uchida, etc. Uchida experimentally proved [8] that a device, which he had designed responded when the generator was switched on at a frequency of 13.0 GHz, with the detector shielded and waveguide outlet closed by a metal blank flange. It is possible to explain this phenomenon considering the fact that the electromagnetic signal in the waveguide excites a torsion signal at the same frequency and that the latter is not screened.

It is noteworthy that the reaction of operators of biological detectors to electromagnetic radiation is probably connected with the specified ability of an electromagnetic field to generate a torsion component.

Shipov's fundamental theory of torsion fields [3], which has allowed us to show the possibility of intensive manifestation of torsion fields, and, hence, provided us with the opportunity to observe strong effects, and, consequently, to solve a wide range of applied problems, has played a very important role in the new revolution in physics. The creation of the world's first torsion generators in Russia in the 1980s [9] was a landmark of this new revolution. A torsion generator is a device generating static torsion fields and undulatory torsion radiation. A number of laboratories united under the auspices of the International Institute of Theoretical and Applied Physics (Russia, Moscow), which is working on a considerable number of projects together with TORTECH USA, have made more than 20 torsion generators of different design over the past 20 years.

The torsion generators make up two groups of devices. The first group includes torsion generators that create static torsion fields of variable intensity and spatial configuration, with different spacing and range. The other group consists of torsion generators that create undulatory torsion radiation of various intensity, different frequencies (with a frequency range from a fraction of a hertz up to hundreds of gigahertz), different frequency spectrums, different types of modulation, and different methods of sending information to different objects. Universal torsion generators have been designed, which, apart from undulatory torsion radiation, can create static torsion fields and torsion currents. In some practical situations, different types of torsion generators have to be used simultaneously.

For 20 years, torsion fields and torsion generators have been widely used to create torsion energy sources, torsion transport, torsion metallurgy, torsion systems of data transfer communication, torsion systems of medical diagnostics, etc. [10]. The feasibility and practical effectiveness of torsion fields has been experimentally proved in a number of areas of application. In some fields, that use torsion technologies (such as nuclear waste processing), a scientific foundation has been laid and preliminary experimental results have been achieved. Technological experience has been gained in some areas.

The peculiar features of a torsion field's properties to a great extent entrain the significant efficiency of torsion technologies and simplicity of the physical and technical means that implement these technologies. I will only outline their basic properties. However, it is noteworthy that all the properties of torsion fields were predicted theoretically and have been confirmed experimentally.

1. Classical spin or macroscopic rotation is the source of torsion fields. A torsion field can be generated by torsion of space or arise as a consequence of perturbation of Physical Vacuum of a geometrical or topological nature. It also can arise as an integral component of electromagnetic field. Torsion field can be of self-generating nature.

The above cases describe torsion fields generated at the level of matter. However, according to the Theory of the Physical Vacuum, there are primary torsion fields that are generated by Absolute Nothingness. Compared with the source material of the world of matter, the fundamental particles appear from Physical Vacuum, which, in turn, arises from the primary torsion field.

2. Tordions are quanta of torsion fields. There are grounds to believe that tordions are neutrinos with energy as low as unities of eV. These neutrinos make up a special class.
3. Since torsion fields are generated by the classical spin, its influence on this or that object is confined only to changing its spin state (the state of nuclear or atomic spins).
4. Unlike sources of electromagnetic and gravitational fields, which create fields with central symmetry, sources of torsion fields create fields with axial symmetry, as shown in Fig. 2.

A spinning object establishes polarization in two spatial cones corresponding to the left torsion field (S_L) in one direction and the right torsion field Fig. 2 (S_R) in the other. Moreover, there is an area of the torsion field that looks like a disk that is perpendicular to the spin axis and passes through the spin center. The axial torsion field appears in the areas described as cones (T_a), while the radial torsion field (T_r) arises in the disk. Each of these torsion fields can be either right (T_{aR} , T_{rR}) or left (T_{aL} , T_{rL}).

5. Compared to electrical charges, like torsion charges (like classical spins ($S_R S_R$ or $S_L S_L$)) attract, while unlike charges ($S_R S_L$) repel.
6. A stationary spinning object creates a static torsion field. If the spinning object has non-

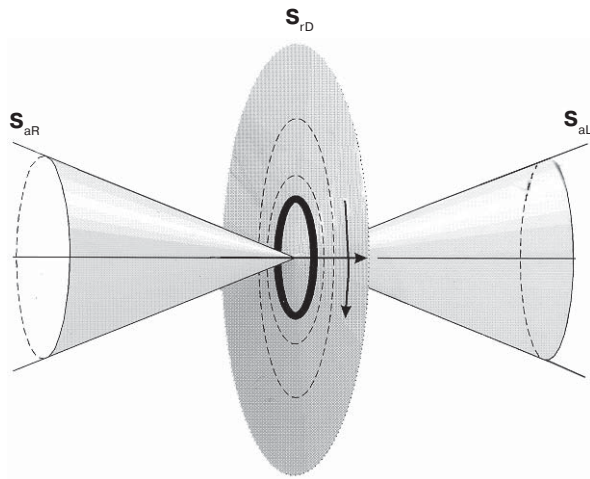

S_{aR} , S_{aL} — right and left axial torsion field of a spinning object
 S_{rD} — radial torsion field of a spinning object

Fig. 2. A spatial diagram of the static torsion field of a spinning object

equilibrium, that is features a change of angular rotational velocity, precession, nutation or moments of greater order in massive objects and a non-uniform distribution of masses with respect to the spin axis, then such a dynamic spinning object creates undulatory torsion radiation.

7. A static torsion field has a limited range of r_0 where the intensity of the torsion field may slightly vary, remaining almost the same as you can see in Fig. 3. Conventionally, by analogy with electromagnetism, although the physics of processes is different here, we can call the r_0 range a short-range zone. Undulatory torsion radiation is not limited by the r_0 range and its intensity does not depend on the distance.
8. The potential of torsion fields identically equals zero, which proves that they are not energetic in nature. This is one of the factors that explain why torsion signals (torsion influence) are transferred informationally rather than energetically, i.e. without transmission of energy and at superlight (infinite) velocity.
9. The Physical Vacuum is the medium in which torsion radiation propagates. Its relation to torsion waves can be compared with a holographic medium. In this medium, torsion waves propagate through the phase portrait of a hologram. This is the second fundamental physical factor that explains the informa-

tional rather than energetic nature of signals transfer, as well as the indefinitely great transfer rate.

10. The constant of spin-torsion interactions, in relation to static torsion fields with Cartan's torsion, is less than 10^{-50} , according to the existing assessments, i.e. such fields cannot produce effects that can be observed. Theoretically, the constant of spin-torsion interactions, as regards undulatory torsion fields with Cartan's torsion (dynamic torsion), is not limited. As far as torsion fields with Ricci's or Weitzenbock's torsion are concerned, they also have no restrictions as to the value of the constant of interactions, and, hence, to the intensity of manifestation of these fields. Torsion fields with torsion that is generated as a component of electromagnetic fields (electrotorsion interaction) have a value of the constant of interactions amounting to $10^{-3} - 10^{-4}$ [3]. This is a theoretical value that has been experimentally confirmed by Professor R. Kuzmin.
11. Since the constant of electrotorsion interactions ($10^{-3} - 10^{-4}$) is slightly less than that of electromagnetic interactions ($\sim 7.3 \cdot 10^{-3}$), in natural conditions such a torsion influence can cause observable changes only in objects in a non-equilibrium state, for example, phase transitions that attenuate electromagnetic connections.
12. A torsion field passes through natural mediums without losses. This is a normal factor, considering that neutrinos are quanta of torsion fields.
13. Theoretically, as it has been pointed out above, the speed of torsion waves equals in-

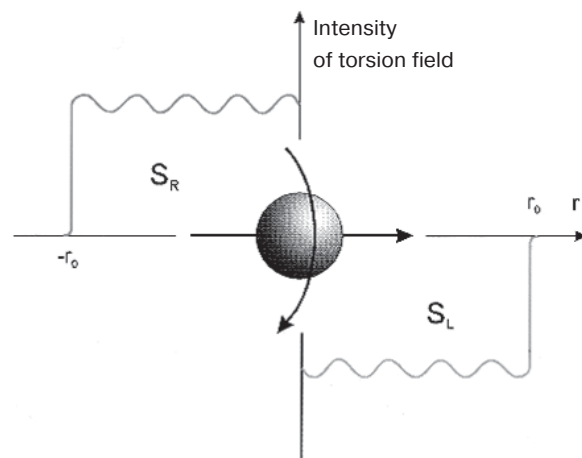

S_R , S_L — right and left torsion field of a spinning object

Fig. 3. Intensity of static torsion field of spin object as function of r

finity. Superlight velocity is not something unusual in physics. It was present in Newton's theory of gravitation, and it makes up the basis of the concept of tachyons. But for them, there would be no Goldstone's theory of the spontaneous disturbance of symmetry. Superlight velocity was first experimentally observed by N. Kozyrev [11], and later confirmed by two other teams. Zeilinger [12] confirmed it at the quantum level. It is worth mentioning here that Soviet physicists noticed more than a decade ago that spin perturbations in spin mediums propagate so that they cannot be screened, which has no relation to torsion fields whatsoever. This means that there is a possibility of underwater and underground connection, as well as connection through any other natural medium.

14. All organic and inorganic bodies consist of atoms, most of which have non-zero atomic or nuclear classical spins. Taking into account that all bodies are placed in the magnetic field of the Earth, considering the presence of magnetic moments of atoms and nuclei caused by classical spins, and charges, precession appears, which generates undulatory torsion radiation. Thus, all bodies have their own torsion fields (radiation).
15. Since different bodies consist of different chemical elements and feature different chemical compounds with different stereochemistry, i.e. different spacing of atoms and chemical compounds in these bodies, each body has a unique torsion field (radiation), i.e. a typical frequency and spatial-frequency torsion field.

No matter how unusual the properties of torsion fields may seem, they should not only be accepted, but also strictly obeyed, since these properties are an objective reality of nature confirmed experimentally.

Many properties of torsion fields, now that they have been formulated, almost automatically allow us to find a property that can be used as the basis for any specific application of torsion fields, given a mere formulation.

We can demonstrate peculiar properties, and hence, manifestations of torsion fields by the following example. Many think that it does not take a scientist to know that physics knows everything about mechanics. In particular, inertia is much spoken about but there is no definition of inertia.

Orthodox physics not only lacks an interpretation of inertia, it cannot even explain whether the forces of inertia are internal or external with respect to moving bodies. The Theory of the Physical Vacuum has shown pretty clearly that inertia is a manifestation of torsion fields in mechanics [13]. It follows from here that if torsion fields can be controlled, it is also possible to control the forces of inertia and, on this basis, make universal propulsion devices that would not feature reactive thrust or friction.

Presumably, Newton's mechanics is based on Euclidean geometry, whereas torsion fields derive from Ricci's geometry, i.e. the geometry of torsion. It is, therefore, quite obvious that Newton's mechanics cannot be applied to systems with spin, just as it cannot be used to describe objects moving at relativistic speeds. In this case, the theory of relativity, based on Riemannian geometry, must be resorted to. It is a special sort of mechanics, i.e. torsion mechanics, that must be applied to systems with torsion rather than Newton's mechanics. The foundation of torsion mechanics was laid by the Russian physicist-theoretician Shipov. Torsion mechanics observes effects that are impossible from the standpoint of Newton's mechanics, just as in the case of quantum mechanics, where phenomena also seem impossible if viewed within the framework of Newton's mechanics. The most unusual factor is the possibility to create, not only theoretically, but also practically, systems that can move using internal forces. A picture of a device that employs the above principle is presented in Fig. 4

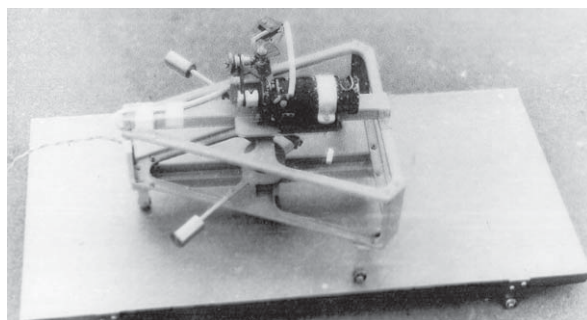

Fig. 4. General view of Tolchin's inertioid

Great emphasis has been placed since the first half of the 1980s on experimental and practical work aimed at changing the properties of different materials by influencing these materials in their various phase states with torsion fields. An example

of such work is research into the influence of torsion waves on smelted metal.

Each experiment features two sorts of smelting, a test and an experimental one. In both cases the conditions remain the same. The only difference is that in the second case the metal in the smelting crucible is influenced by a torsion generator producing torsion waves ranging from 1 to 150 Hz and placed about one meter from the Tamman's furnace. The time of exposure is 15–20 minutes. As soon as the smelting is over, each furnace is left to cool down. Then the ingots are removed from the crucible and sections are taken to study the structure of the metal.

We would like to point out that in such experiments the torsion field made metal grains almost identical with respect to their dimension, they became bigger, and the structure of the metal became almost completely isotropic. Such metal is stronger and more ductile. The results were obtained in the late 1980s. In the ensuing years, a number of alloy production torsion technologies have been developed and patented. Torsion modes have been established that help reduce the size of grains, and in some cases change the crystal lattice.

A new torsion technology for production of silumin, a mixture of aluminum and silicon, has been developed in Russia. Unlike standard silumin production technologies, torsion technology does not require employment of alloying additives to increase the metal's strength. Nor does it require special chemical additives to fix gases in the silumin. If torsion technology is used, torsion waves of a certain spectrum alone force gas bubbles out and increase the strength by 1.3 times and ductility by 2.5 times. The simultaneous increase in strength and ductility by means of torsion radiation is impossible from the point of view of standard technologies.

Considering the pressing nature of the global energy crisis, coupled with the impossibility of a radical solution to this crisis using solar energy, wind, thermal sources etc., there have been quite frequent suggestions that the energy of the Physical Vacuum should be used instead.

Physicist-theoreticians have two points of view on this issue. One point of view boils down to the statement, that since the Physical Vacuum is an object with minimum energy, the idea per se to use it as an energy source makes no sense.

The other point of view recognizes that elements of the Physical Vacuum, the oscillators, which do not interact, possess energy that is infinite. A number of Russian physicists, including Academician Ya. Zeldovich [15], have pointed out that this infinite energy has usually been overlooked, have announced it unobservable and called it a "zero level", making this indefinitely high level a benchmark, for example, to calculate the energy of particles. J.A. Wheeler [16] is known for his estimation of the energy of fluctuations of the Physical Vacuum, which can be viewed as the lower boundary of this energy, amounting to 10^{95} g/cm³. For comparison, we shall note that nuclear energy is estimated at the density of the nucleus, making 10^{14} g/cm³, and the energy produced by burning oil is estimated at a density of about 1 g/cm³.

If the energy of the Physical Vacuum is unlimited, then increase in power consumption for the needs of the Earth (not mentioning here the problem of heat balance), with the help of the energy of the Physical Vacuum cannot affect it in any way.

Recognizing that the theory lets in the possibility to develop energy from the Physical Vacuum, the problem consists in detecting the physical principles that need to be used as the basis to make equipment capable of solving the problem and subsequently searching of technical solutions of an appropriate commercial nature. These physical principles are the focus of a number of research groups. However, I have not heard that anyone has solved this problem. At the same time, there are many devices, which, according to their inventors, have an efficiency factor exceeding unity [17].

Usually, the psychological power of physics as it is taught in schools asserting that an efficiency factor cannot exceed unity, appears to be stronger than data obtained in higher educational institutions. Any standard course of thermodynamics contains strict proof that closed systems truly can never have an efficiency factor greater than 100 percent. However, if the system is of an open type and thus can get energy from outside, such a system can have arbitrary large efficiency. Thus, if an inventor asserts that he has designed a system with efficiency of more than 100 percent, it seems senseless to discuss whether or not it is possible. There are only two questions that matter. The first is whether the procedure is correct and whether the equipment complies with the requirements for definition of a system's efficiency. In a great

number of cases, inventors declare 100 percent-plus efficiency because either the method of measurement or the equipment has been improperly chosen or used.

If the system's efficiency is measured correctly and efficiency is indeed more than 100 percent, this automatically means that the system is of an open type and this is the case when the second question needs to be answered: **What kind of energy gets into this system and through what channel?** When the research discloses the channel and the kind of energy and as soon as this energy is incorporated into the total system's energy balance, its efficiency again drops below 100 percent.

Thus, when the efficiency of a system is measured to be more than 100 percent, it only means that we do not know very well how this system works. In this connection there is a proposal that it would be more logical to use the term "effectiveness ratio" rather than efficiency when dealing with open type systems. In terms of standard terminology, some systems of an electrostatic, magnetic, electromagnetic or thermal type are known to have an efficiency of up to 500 percent. In most cases, the figure is declared by inventors in patents. In one patent, for example, the device was declared to have an efficiency of 3,000 percent. However, as a rule, the evaluation (by an independent expert) does not confirm such high figures. This might happen if inventors conceal their methods know-how or because the system is hard to produce.

Russian inventors, as well as those in the CIS nations, have focused on thermal systems with an efficiency greater than 100 percent. Among the great number of such systems there are ones whose efficiency reaches 400 percent. However, only one design of a thermal system whose mass production variants passed independent expert evaluation several years ago, proved to have an efficiency greater than 120 percent. Construction of such a system is scheduled for 2001.

Since spiral movement generates a torsion field, which is registered by torsion field measurement devices, it can serve as the grounds to consider that interaction of the system's torsion field with torsion fields of spin clusters (clusters of fitons [18]) of the Physical Vacuum causes a small amount of the energy of the fluctuations of the Physical Vacuum to be shared with the object that generates the torsion field of the system, i.e. the water spiral. This makes the temperature of

the water rise. One could think that the water heats itself. Considering that the energy that heats the water is caused by torsion effects, and also taking into account that this mechanism is implemented through a spiral, vortical process, and that the system is designed to obtain extra energy, this thermal heating installation was called the Torsion Vortex Generator (TVG).

It follows from the above that the Torsion Vortex Generator has two energy sources: the electric mains supplying power to the electromotor, which is necessary to pump the water through the system, and Physical Vacuum, which gives out the energy to heat the water. In the future, when the efficiency of such systems is considerably higher, i.e. more energy is taken from the Physical Vacuum, part of the thermal energy, taken from the Physical Vacuum, might be transformed into electrical energy and supplied to the electromotor. In this case, the mains will not be necessary any longer and such a thermal system will become completely independent. Such a system will become an independent source of energy. When this happens, it will be a revolution in power engineering in general. It is not important whether this system is going to be thermal, electric, magnetic or of any other construction.

An important direction of the work connected with the Physical Vacuum and torsion fields has consisted in fundamental and applied medicobiological research. Of great importance has been the research into the influence of static torsion fields and undulatory torsion radiation on various sorts of living organisms, as well as research into the integral and characteristic torsion fields inherent in various living organisms. The latter has become possible due to creation of highly sensitive quantum systems recording torsion radiation and its frequency spectrums.

A database containing spectrums of torsion radiation of different tissues at various stages of different diseases has been being collected for a long time. It gives us the opportunity to make equipment to check a person's health, measuring characteristic spectrums of torsion frequencies of specific groups of cells or tissues of any part of a human organ and comparing them with the respective spectrums of healthy cells or cells with different degrees of pathology.

A system designed to diagnose a person based on the records of his torsion fields is called the Torsion Diagnostics system (TORDI). To correctly

understand how it works, a number of things must be explained. Van Hoven's theory features the following conclusion: in order to obtain complete information about any system, it must be destroyed. However, destruction of a person's tissues in order to get information about their state is too high a price to pay for the information about his health. However, Van Hoven's criterion can be satisfied with the minimum influence, when the cells are not destroyed and the atoms of these cells, being primary sources of torsion spectrums to be registered, are rendered as non-equilibrium by means of an outside disturbing influence. In order to choose the frequency of the disturbing torsion influence correctly, it is necessary to take account of the role played by water in the physical and biochemical organization of tissues of the human body. At the same time, it is necessary to take account of resonance torsion frequencies of various human organs. Finally, it turns out that the signal of torsion disturbance must be rather sophisticated, considering both these factors.

The TORDI system is a ready-to-use production device. Nevertheless, it is important to understand that the model is not a limit of the scientific and technical potential incorporated in it and that enhanced versions of the system are sure to appear in the course of time.

Summing up, I would like to draw your attention once more to the fact that work on torsion technologies is not limited by the lines of research that have been discussed here. Actually, as it was pointed out in the beginning, on-going development embraces all branches of economics, including industry, agriculture and medicine, as well as all problems that arise in everyday life.

The torsion technologies that have been touched upon here signify that mankind is on the threshold of the age of torsion technologies, which, we believe, will change our life in the 21st century more than all the scientific and technical revolutions of the 20th century.

REFERENCES

1. Cartan E. Comptes Rendus. Akad.Sci., Paris, 1922, v.174.
2. V.Melnikov, P.Pronin. The problem of gravitation constant stability and additional interactions. Itogi Nauki I Tekniki, ser. Astronomy, v.41, Gravitation and Astronomy, Moscow, VINTI, 1991.
3. G.I.Shipov The Theory of the Physical Vacuum. Gard, Moscow 1998
4. I.Ternov, V.Bordovitsin. On the modern interpretation of the classical spin theory of Ya.Frenkel. UFN, 1980, v.132, No.2.
5. V.Bagrov, V.Bordovitsin. Classical spin theory. Izvestiya VUZ, Phys.Series, 1980, No.2.
6. F.I.Belinfante. On the spin angular momentum of mesons. Physica VI, 1939, v-6, No.9.
7. M.Markov. The very early universe. Proc of the Nuttfield Workshop, Eds. G.V.Gibbson, S.W.Hawking, S.T.Siklov, Cambridge, 1988.
8. Hideo Uchida. A apparatus for detecting a fluid. Patent England, No 511662, May 24, 1978.
9. Anatoly Akimov. A heuristic discussion of the problem of finding long-range interactions. EGS-concepts. CISE VENT, preprint N7A, Moscow, 1992.
10. IITAP RANS, TORTECH USA, Horizons of the Science and Technology XXI age Proc, Editor A.E.Akimov, Folium, Moscow, 2000, vol.1 (in Russian).
11. N.Kozyrev, Astronomical observations by means of the physical properties of time. In "Flarestars" International Symposium in Byurakan, 1976, Armenian Academy of Sciences Publ., Yerevan, 1977 (in Russian)
12. Bouwmeester D. et.al. Nature, v.390, 11 dec, 1997.
13. G.I.Shipov. Theoretical and Experimental Research of the Inertial Mass of the Four-Dimensional Gyroscope. ITTAP RANS, preprint N10, Moscow, 2001, (in Russia).
14. The way of correction of metal alloy microstructure. Patent Russian, RU 2107105, 1998.
15. A.Dolgov, Yu.Zel'dovich, M.Sazhin. Cosmology of the Early Universe. MGU Publ., Moscow, 1988.
16. I.A.Wheeler. Fiustein's vision. Springer Verlag, 1968.
17. Convegno Internazionale:Quale Fisica per 2000, Proc. Bologna, 1991. see: The Manual of Energy Derices and Systems. Compiled D.A.Kelly, D.A.K. WLFUB, Burband, California, 1986, Publ. N1269/F-289.
18. Daytlov V.L. Polarization Model of the Ungomogendous Physic Vacuum. Institute Mathematical, Sibirians Academic Science, 1998 (in Russian).

The Antigravitational Platform And Experiments With the Effect Of Multi-Cavity Structures

Reviewed by **N. OVTCHARENKO**

Meeting our readers' wishes halfway, we publish a review of works by V.S. Grebennikov and V.F. Zolotarev, who in 1985 applied for a patent for discovering "The phenomenon of the interaction of multi-cavity structures with living systems" (Russian Federation patent priority #32-OT-11170 of 03.09.1985).

In issue #1, 2001 of our magazine, we published an article containing Professor Zolotarev's calculations of the effects observed in multi-cavity systems. The essence of the present effect lies in the interaction of biological systems with de Broglie waves. The appearance of the latter is related, in Professor Zolotarev's opinion, to the group movement of electrons inside solid bodies containing cavities that act as de Broglie wave resonators. This, in turn, results in the appearance of standing de Broglie waves. The amplification of the observed effect is caused by the rhythmic spatial structure of field-generating cavities.

Professor Zolotarev assumed that since only interrelated natural categories may interact, the physical mechanism of nerve impulses has much in common with de Broglie material waves, which are, supposedly, longitudinal.

Technical application of the effect in question can be realized by means of several methods. "The walls of multi-cavity structures... are usually con-

sidered to be the boundaries of a potential electron well. In general, this is true for dielectrics as well as for metals. Group movement of electrons results in the appearance of a system of de Broglie standing waves, having **classical frequencies**, in the potential space". (B.N. Rodimov, *Self-Oscillatory Quantum Mechanics*, Tomsk, TSU, 1976).

According to Zolotarev's calculations, the length of a standing wave is twice as large as the size of a potential well. The frequency of a standing wave equaling 2 Hz constitutes a threat to a person's health since it can result in interaction with central nervous system impulse frequencies. Thus, taking into consideration the experimenter's sensations, we come to the conclusion that the human body interacts with de Broglie waves that "pierce" it. The character of resonant interaction implies the diversity of wave lengths and frequencies, determined by the geometric dimensions of the interacting structures.

It is difficult to overestimate Professor Zolotarev's contribution to the theoretical study of the essence of the present effect, but the variety of methods of its practical implementation can be found in the works of V.S. Grebennikov.

In his book "*My world*", the scientist gives a description of numerous experiments, making it possible to reveal the manifestation of the effect of multi-cavity structures. The effect was discovered by Grebennikov during his study of the morphology of insects, in particular of chitinous covers of some parts of their corpora. He

writes that an “unusually rhythmic microstructure” of one of the insects’ wings roused his interest. He observed an unusual effect when he tried to juxtapose two identical details under a microscope: the detail “...broke loose from his tweezers; for a few seconds it hung suspended above the other plate on the microscope shelf, turned a few degrees clockwise, slid to the right, turned counterclockwise, swung, and only then abruptly fell on the desk”.

The effect of antigravity, discovered by Grebennikov and caused by multi-cavity structures, was implemented by him during the creation of his most interesting, in our opinion, invention — the antigravitational platform. In his book, the scientist describes his experience of flying the platform (its main view is shown in Fig. 1 and 2).



Fig. 1

Grebennikov writes that during the flight (Fig.3) he was standing on a flat rectangular platform, slightly exceeding the seat of a chair in size. A steering column with two handles (field regulators), by means of which the device was controlled, was mounted on the platform. He also mentions other parts of the antigravitational platform. Thus, Grebennikov writes that the descending and braking of the platform is achieved by means of “cross-shifting filter blinds” (which the author also calls “micro-cellular gravitational filter blocks”) situated beneath it. The author also



Fig. 2

mentions “blocking panels”, the malfunction of which was the cause of difficulties experienced by the inventor during his first test flight.

The steering of the antigravitational platform was performed by both handles in the following way. The left handle was used to control the gravitational filter blinds. By means of joining or parting these blinds, the ascending or landing of the device was performed. The right handle was used for a horizontal, onward movement that was achieved by inclining of both groups of “wing case” blinds via a flexible cable situated inside the steering column. In his book, the author declares that he was able to achieve a speed of 150 km/h, which can be easily increased up to 1500 km/h.

During the test flight, performed by the author on March, 18, 1990, such anomalous effects as the slowing of time and spoiling of photographic films were observed by him.

The effect of multi-cavity structures was studied by the author during numerous other experiments. Our readers can carry out the majority of these experiments themselves since they do not require the use of any special equipment. A description of some of these experiments is given below.

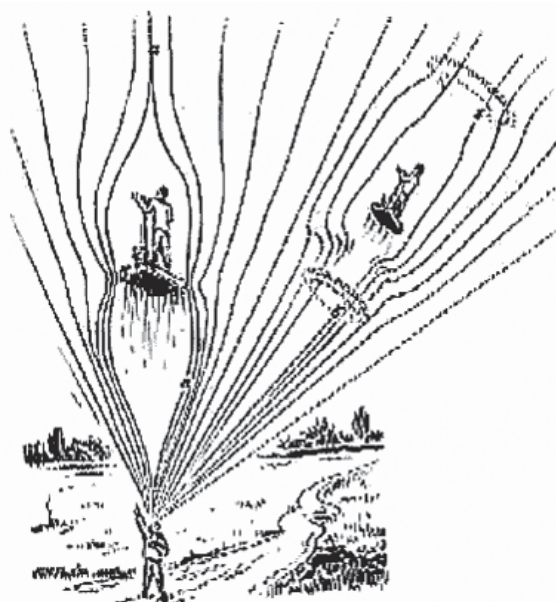

Fig. 3

Note: all the pictures and photos, which the present article comprises are taken from V.S. Grebennikov’s book “My World”.

“Perpetuum Mobile”

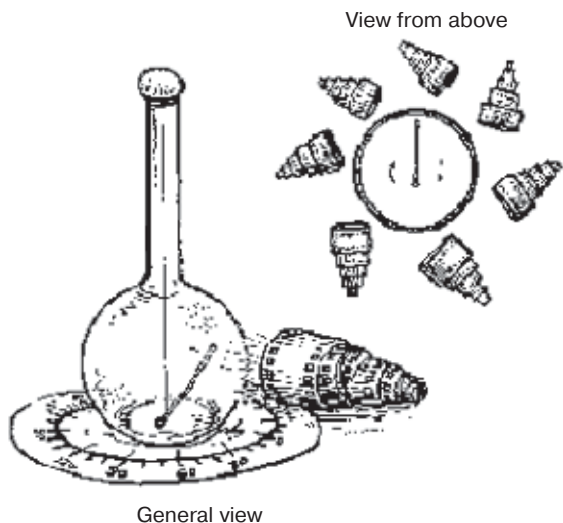

Fig. 4

In order to carry out this experiment, seven rolls of used film should be arranged in the way shown in Fig. 4. The rolled-up films should be placed around the apparatus shown here. The device also has an inclined single-arm straw indicator, hung on a thin thread (a small piece of plasticine was used as a counterbalance). Slowly leaving the zone of impact of one roll, the straw would enter the power field of the second, then the third, and so on... This experiment is most successful in a sound-insulated chamber, away from wires and pipes, as well as of sources of heat, cold, and bright light.

Artificial Honeycomb

Take a dozen and a half papier-mache supermarket egg cases (the 30-egg variety), tie them up or glue them together (one on top of another) in such a way as to join the “teeth” to one another (Fig. 5). Fix the whole set (it can be enclosed in a case) over the head of a person sitting in a chair, with the bottom “comb” 10-20 cm above the head. Leave the person there for

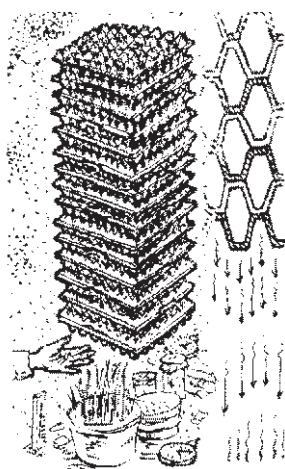

Fig. 5

10-15 min. The “unnatural”, unusual transformation of the spatial shape formed by the set can be picked up even by the palm of a hand. Experiment with couching seeds, or breeding microorganisms and insects, under a “macrocomb” and compare the results with those of identical experiments conducted at least 2 m away from the comb. Repeat each pair of experiments several times.

Paper Emanators of The Effect of Multi-Cavity Structures

6 sheets of office paper should be cut in two, then lengthwise and folded accordion-like so as to get 10 edges and 20 surfaces. Squeeze the “accordions” to make them square and glue them on top of one another, turning each horizontally 30 degrees clockwise against the bottom one (Fig. 6).

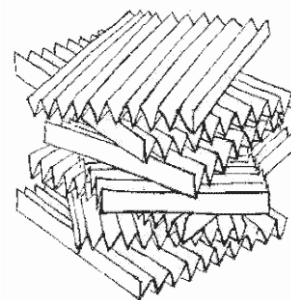

Fig. 6

Moving “Combs”

Make a wooden spinning top and drill several holes on its sides, making sure to go all way through. They should be pencil-width in diameter or a bit wider (Fig. 7). Their cavity effect will significantly increase if the top is rotated, and this can be easily perceived by the palm of one’s hand. This is due to the fact that the number of holes is numerically multiplying in space.



Fig. 7

The complete text of Grebennikov’s book “My World”, comprising descriptions of his unique experiments, can be found on the web-site: <http://www.keelynet.com/greb/greb.htm>.

Vortex Heat Generators (VHG)

Yu.S.POTAPOV, Russia

The author is a Doctor of Technical Sciences, a professor, an Academician of the Russian Academy of Natural Sciences; an Academician of the International Academy for Leadership in Business and Administration, USA; an Honorary Inventor, a Birmingham Torch Award winner, USA; an All-Russian Exhibition Center Award Winner and an Honorary Doctor of Sciences.

Application of vortex heat generators

Vortex heat generators of the seventh generation are designed to provide autonomous heating and hot water supply for households and industrial buildings. They may also be used by specialists for practical and research needs. The generators are operated in direct, automatic and remote modes depending on outdoor conditions. A vortex heat generator's load percentage amounts to 10% a day. The efficiency factor of a vortex heat generator (the efficiency of energy conversion according to EEC standards) is 220%. It has demonstrated a two-fold reduction in energy consumption. The system has a payback period equaling no more than a single heating season.

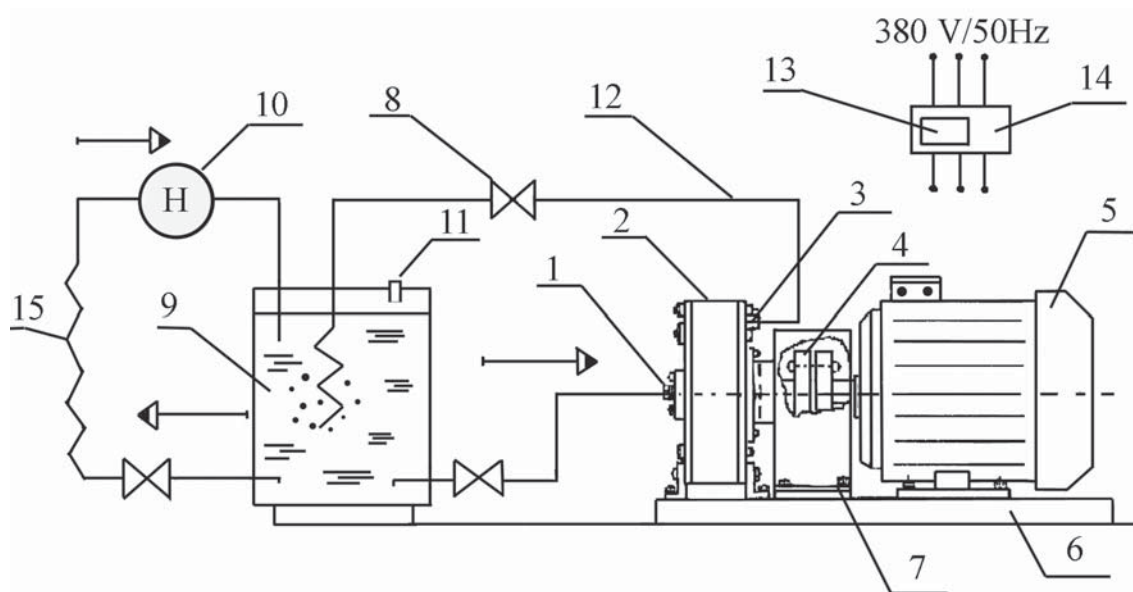

Fig. 1. Vortex heat generator operation scheme

- | | |
|----------------------------|-------------------------------|
| 1. Inlet connection | 9. Boiler |
| 2. Vortical heat generator | 10. Circulation pump |
| 3. Output connection | 11. Air valve |
| 4. Coupling | 12. Pipeline |
| 5. Motor (electric motor) | 13. Microprocessor |
| 6. Frame | 14. Starter |
| 7. Casing | 15. Radiator (heat exchanger) |
| 8. Cock | |

The conception and design of a VHG

A vortex heat generator consists of a cylindrical case and a rotor. The rotor is rotated by an electric motor. The generator has an accumulating cell for night operation. Working fluid (water) is tangentially directed to the vortex heat generator's inlet. Then the water, run along a complex route, gets hot. By the time this happens, more than 500,000 cycles of compression and expansion of the water have taken place. The heating is performed due to the friction of water molecules and the processes of cavitation and fusion.

The system, equipped with a microprocessor, operates in a pulse mode and maintains the assigned temperature regime at different outdoor temperature values. Two-year operation of a new generation VHG in Moscow has shown that no complex and expensive service is needed. The difference between a new VHG and a VHG of the first generation lies in the fact that the new VHG operates without an electric pump, heating water up to 95°C in one operation. Steam formation is also available. The experience operating of a VHG (by implementing the new technology in factory conditions) has demonstrated that the cost of heating of 1m³ of a premise's volume averaged \$ 0.63 a year. Compare:

- Average cost of heating by means of an electric boiler – \$ 16.18
- Average cost of heating by means of a boiler operating on burning liquid fuel – \$ 8.81
- Average cost of heating by means of a gas boiler – \$ 1.23

Potapov's vortex engine

The new type of vortex engine is intended to be installed in vehicles (cars, buses, boats, submarines, aircraft, locomotives, helicopters, armored vehicles, electric power stations etc.). It is a fully autonomous electric power station. It operates on ordinary air. When the engine rotor reaches the design number of rotations, the electric generator is switched on. About 30% of the total output power is used to keep the engine running, while the remaining 70% are supplied to the consumer.

It is well known that the efficiency of a combustion engine averages 40%; of a steam engine 12%; of an atomic engine 34%; of a gas engine 30% and of a hydrogen-fuelled engine 45%. All types of engines operating on the principle of combustion (including hydrogen combustion) pose danger to humanity since 1 kg of fuel consumes about 300 liters of air while burning. A 50 kW engine exhausts about 3,000 liters of odorless gas during operation. The exhausted gas comprises 200 poisonous elements harmful to human health.

A catalyst doesn't help solve the problem. The use of hydrogen causes the greenhouse effect, which could lead to global disaster. A hydrogen-fuelled engine releases steam into the atmosphere. This steam is responsible for 90% of the greenhouse effect on the Earth. Besides, hydrogen consumes the same volume of air as gasoline while burning; the processed air being exhausted is irrespirable.

In Potapov's new engine (a picture of it can be seen on the cover) the inlet air pressure amounts to 0.01–0.09 Atm. This range of pressure values defines the number of rotations per minute at which power take-off takes place: 960–16,700 rpm. Air consumption is minimal (Table 1).

Potapov's engine does not affect the chemical or physical state of the air during operation. The exhausted air is respirable without any limitations. The engine goes through a bench test, first at idling speed and then with a load. The output engine power amounts to 700 kW. The total mass of the engine with a reduction gearbox is about 80 kg. The overall dimensions of the 700 kW engine (without an electric generator) are: 900×500×750 mm. The noise level, which is adjusted by shock absorbers and a noise-absorbing bonnet, accounts for 2–35 dB.

The patent for Potapov's engine and the method of power generation used in the engine are protected by law. Anybody reproducing the present method or the construction of this engine will be prosecuted according to international law and the laws of the Russian Federation. The cost of a production license is agreed by contract. The cost of a demonstration is also agreed by contract.

Table 1

№	Air temperature, °C	Turbine acceleration time, sec	Turbine overtravel time, sec	Inlet pressure, Atm	Revolution number, rot/min
1.	20	5	68	0.01	964
2.	21	3.5	87	0.03	4,100
3.	21	2.7	160	0.05	8,120
4.	23	2.0	180	0.07	12,100
5.	23	1.5	195	0.09	16,700

Fuelless Air Combustion

Alexander V. FROLOV

Faraday Lab Ltd., Director General
Lev Tolstoy Str., 7–601, Saint-Petersburg,
197376, Russia
7-812-3803844

Air autothermia – the effect of fuelless air combustion, which is used, in particular, in a modernized automobile engine, is described in detail in a book called “*Natural Power Engineering*” written by E.I. Andreev [1]. Experiments carried out by a group of researchers in 2001 showed that it is possible for carburetor engines to function with minimal fuel consumption due to the fact that the engine’s air-fuel mixture is processed in a certain way.

According to Andreev’s theory, fuelless air combustion starts when there is a minimal quantity of hydrocarbons and is based on an avalanche-type reaction when, for example, the hydrocarbons’ free electrons interact with oxygen atoms. One of the best-known examples of this effect is the explosion of an oxygen cylinder when oil is present on its external surface. The chemical reaction of the combustion or explosion of pure oxygen can be represented as a dissociation of an oxygen molecule into atoms and electrons, followed by a recombination of the oxygen atoms accompanied by an energy output. It is important to emphasize that the present cycle has earlier been studied as applied to hydrogen. The effect of heat liberation during the process of recombination of atomic hydrogen is used in hydrogenous welding sets for the creation of temperatures of about 5000–8000 degrees Celsius. Developing this method, our company has created a device in which a closed

circuit of dissociation and recombination of hydrogen can provide for a high efficiency heat output.

The change in the composition of exhaust gases of the engine, which consumes less fuel during its operation [1, page 11], leads us to the conclusion that nitrogen is involved in the process of combustion, since its percentage diminishes. The percentage of water vapor increases at the output; the presence of carbon in the form of small-sized graphite particles has been registered. With a large quantity of hydrocarbonic fuel (a rich air-fuel mixture) the excess of binding electrons in the fuel impedes air autothermia; that is, the combustion of the fuel itself with oxide formation can usually be observed. According to Andreev’s method of autothermia, catalysis can be achieved by means of magnetic treatment of air. Not fuel electrons but binding electrons of air itself are used during the process.

Let us consider the role played by the magnetic field in detail. As shown in the book [1], the magnetic field represents a flux of small positive particles called “electrino”, which are considered in detail by D.H.Baziev [2]. I believe that we should consider the magnetic field as a flux of aether particles instead of introducing new concepts; I find it to be more traditional and promising. Thus, Andreev writes: “...by means of a magnetic flux, the electrino vortex around the atoms in the catalyst may be amplified... which will make it possible to amplify the processing, for example, of air...”. On the other hand, we can do without considering the electrino if the physical essence of magnetic flux is presented from the classical point of view of aetherodynamics. Particles of a substance are considered as vor-

tex structures. Since in the area of the magnetic flux the aether's pressure changes, the conditions of chemical reactions change as well.

Moreover, aetherodynamics does not consider charges of aether particles. Andreev shows [1, page 75] that the effect of leakage of the magnetic induction between poles (the divergence of magnetic field power lines in air) is determined by the fact that molecules of a substance (nitrogen, for example) capture the electrino from the magnetic flux, set them spinning and throw them out of the main flux. It deforms magnetic field power lines. It is obvious that the charge of the electrino does not make any difference and we can simplify the situation by considering molecules as vortex processes taking place in aether. The magnetic field should be regarded as a flux of aether particles.

The example of rare earth metal combustion in open air, considered in the book [1], is also regarded as a catalytic reaction. Rare earth metals, due to their specific structure, can be regarded as powerful concentrated vortex processes taking place in aether. Due to this, they represent catalysts of the transformation of oxygen into an atomic state (dissociation), while the ensuing oxygen recombination leads to heat output.

It is evident that research in the field of air autothermia is one of the most promising trends of al-

ternative energetics. One of the major advantages of this approach lies in the possibility of using standard carburetor internal combustion engines as a base for new energy installations. On the other hand, the understanding of the processes of air autothermia draws our attention to other natural physical mechanisms that could be used in fuelless power engineering. The analogy between the processes of dissociation and recombination according to the theory of Andreev and similar processes observed in our laboratory has been drawn above. The common point of these two approaches lies in the fact that special dissociation conditions allow achieving the transmission of a substance into an atomic state with minimal energy consumption, while the process of recombination provides for heat output. By means of such a natural method of using a symmetrical fuelless dissociation-recombination cycle, the problem of heat emission or heat absorption could be solved.

Faraday Lab Ltd. is interested in the development of contacts with investors in this particular field of research.

REFERENCES:

1. E.I. Andreev, Natural Power Engineering-3, Saint-Petersburg, 2003.
2. D.H. Baziev, The Charge and Mass of a Photon, Moscow, 2001.

New Energy Technologies

Printed edition advertizing rates

<p>Full page ad</p> <p>B/W – \$400 In colour – \$800</p>	<p>Half-page ad</p> <p>B/W – \$200 In colour – \$400</p>	<p>A quarter page ad</p> <p>B/W – \$100 In colour – \$200</p>
---	---	--

tel/fax 7-812-380-3844
<http://www.faraday.ru>
office@faraday.ru

A Free Energy Generator Based On Mechanically Changed Capacitance

Zoltan LOSONC, Hungary
feprinciples@on.mailshell.com

Editor: *In the present article the author reinvents the principles of designing parametric capacitors. These principles were developed way back in the middle of the XXth century by Academician N.D. Papalexi. He proved that, according to his own words, the “effectiveness of obtaining electrical energy using my method may amount to 99% and higher...”.*

There are several types of energy converters that convert mechanical energy into electrical energy by changing the capacitance of a charged condenser. The energy content of a capacitor can be calculated with the simple formula of $W=Q^2/(2C)$. We can conclude from this correlation that if the capacitance C of the condenser is decreased while the stored charge Q is kept constant (i.e. while the capacitor is disconnected from the power supply) the energy stored in the capacitor will increase.

The capacitance of a condenser can be changed by mechanical means in different ways. The formula of a flat capacitor $C=eS/d$ shows that the capacitance depends on 3 parameters: the permittivity e of the dielectric between the plates, the surface area of one side of one plate S , and on the

distance between the plates d . By changing one or more of these parameters the mechanical energy can be converted into electrical energy. These methods are illustrated in *fig. 1*.

- In the first example (*fig. 1a*, which corresponds to the changing of e) the capacitance is decreased by removing the solid dielectric from the capacitor with a mechanical force F . This force is opposed by the edge effect forces F_{ee} at the edge of the capacitor, because the dielectrophoretic forces tend to pull the dielectric back into the capacitor.
- In the second case (*fig. 1b*) the capacitance is decreased by increasing the distance d between the plates. This movement is opposed by the electrostatic pressure forces F_{ep} that pull the plates together.
- In the third example (*fig. 1c*) the distance d between the plates remains constant, but the upper plate is moved in horizontal direction parallel with the lower electrode, and by this the effective adjacent surface areas S facing each other will be diminished. Since in electrostatics the electric field lines are always perpendicular to the surface of a conductor, and the electric forces act along these E-field lines on that surface, the only places where braking F_{ep} forces can appear are the edges of

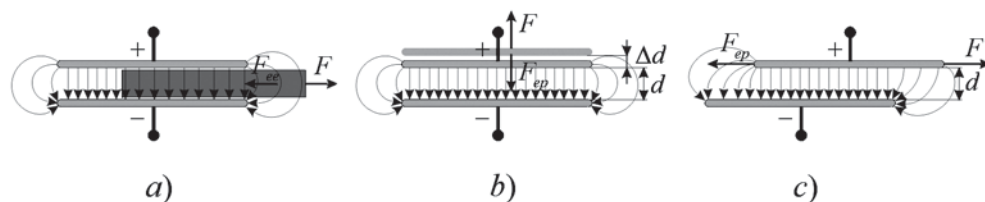

Fig. 1

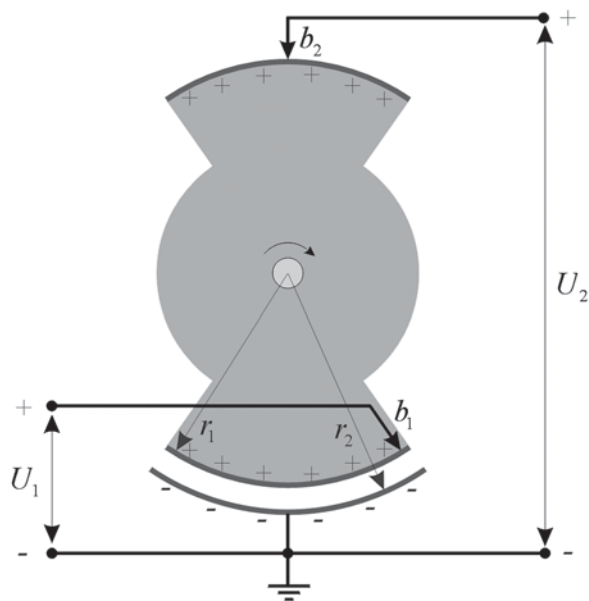

Fig. 2

the moving electrode. The edges are the only places where these force lines can have horizontal component parallel to the movement's direction.

A practical realization of a simple electrostatic energy converter is shown on *fig. 2*. This device is a mechanical DC/DC converter, when a lower input voltage U_1 is converted into a higher output voltage U_2 while the input and the output currents are the same, and consequently the output power is greater than the input electric power. However, this is not a free energy generator since no excess energy is generated, but only mechanical energy is converted into electric energy. The law of energy conservation remains valid in this case since the electrostatic retarding forces unnecessarily waste the driving mechanical energy.

The rotor is made of an insulator material mounted on a shaft so that they can rotate together. On the two opposite sides of the rotor two metal electrodes are mounted. When one electrode of the rotor is facing the grounded stator segment below, they represent a capacitor that is charged to voltage U_1 through the lower brush b_1 . By turning the rotor clockwise the charged electrode on the rotor is disconnected from the brush b_1 and moved to the upper position. This rotation is opposed by the attracting F_{ep} forces shown on *fig. 1c*. When the charged electrode touches the upper brush b_2 the car-

ried charge can be extracted under a higher voltage U_2 , since the distance to the grounded electrode have increased and their mutual capacitance have decreased.

It is important to recognize the principal similarity of this converter with the case shown in *fig. 1c*. The key feature of both cases is that the only place on the moving electrodes where the unwanted braking forces can appear is the edge of the moving electrode. The main horizontal surface of the electrode does not contribute to the retarding electric forces, since the E-field and force lines are perpendicular to the surface. On *fig. 1c* this is perpendicular to the movement, and in the last example the forces point in radial direction, thus they can not develop retarding torque on the shaft. This observation readily offers **a possibility that if we can eliminate the retarding electrostatic forces at the edges, then we can construct a generator that will produce more output energy than the total sum of the input electrical and mechanical energies.**

The unwanted electrostatic drag

Let us examine a little deeper these unwanted retarding forces at the edge of the moving electrode. A modified version of the discussed converter with double grounded stator plates is shown on *fig. 3a*. The double stator electrodes ensure greater capacitance, higher energy density per volume, and a beneficial symmetrical configuration. On the top and bottom flat surfaces of the moving electrode (between the two stator plates) the electric forces are perpendicular to the movement, thus they can not exert any retarding force. The only places where the electric forces can have a horizontal component parallel to the movement are the edges. At the front edge f only a minor accelerating force F_a can appear since the E-field intensity is much weaker here than at the back edge b between the plates. Thus the retarding electrostatic force upon the aft edge F_r will overweigh the accelerating force F_a , and if we want to maintain the movement, an additional external mechanical driving force of $F_m = F_r - F_a$ is required. The work performed by this mechanical force (while opposing the unwanted electrostatic retarding forces) will be the same as the increase of the electrical energy in the capacitor.

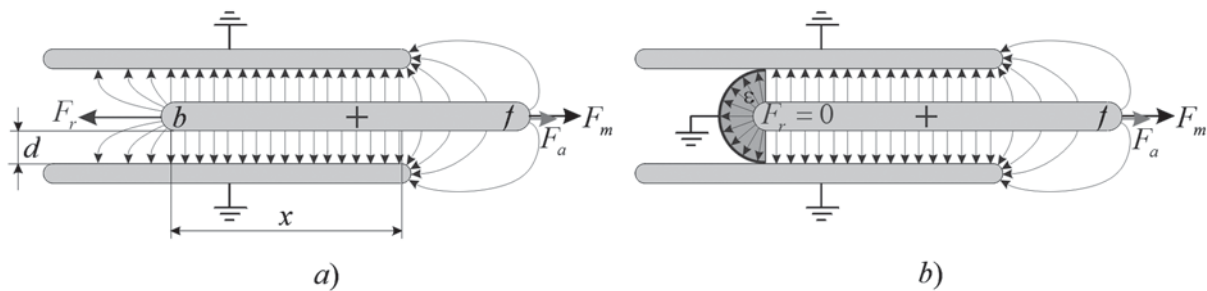

Fig. 3

Free energy is generated by eliminating the retarding electrostatic drag

The braking effect of the electrostatic forces at the aft edge of the moving electrode can be neutralized by binding them to their own reaction forces. This is accomplished by surrounding the edge with a grounded conductive semi-cylindrical electrode, and filling the gap between this semi-cylinder and the edge with solid dielectric as in *fig. 3b*. **This drag-neutralizer is practically a semi-cylindrical thruster element and capacitor, which is mechanically attached to the aft edge of the moving electrode and they move together.**

There are 3 active forces within the thruster element. The first is the electrostatic pressure component that pulls the inner surface of the outer semi-cylindrical electrode towards the plate's edge. The second is a similar but greater force pulling the moving electrode's edge backwards. The resultant of these two components will be a backward retarding force. Related calculations about the magnitude of these electrostatic pressure forces can be found on the page ethrform.htm. The third force is a dielectrophoretic force that pushes the dielectric towards the plate's edge. This type of force has been discussed on the page dielforce.htm and related estimating calculations can be found on the page fullcylsph.htm. According to these calculations a non-zero unidirectional thrust is expected to act on a semi-cylindrical thruster element filled with dielectric, directed from the bigger semi-cylinder towards the smaller one. This non-zero thrust was expected, since the dielectrophoretic force upon the dielectric was calculated to be greater than the electrostatic pressure forces on the electrodes, having the opposite direction.

Two experiments have been conducted so far for the practical detection of the expected thrust upon a semi-cylindrical thruster element. The first experiment was carried out by Andreas Pramesberger. He constructed a semi-cylindrical thruster with rounded edges to avoid electric breakdown, and molded it into paraffin wax. The drawing and related information can be found on the page thrusterproject.htm. Andreas has observed a small unidirectional thrust directed from the bigger towards the smaller electrode. After increasing the thickness of the paraffin layer on the side of the smaller electrode this thrust completely vanished and no unidirectional thrust was observed. However, the originally observed thrust cannot be explained with the effect of air ionization, because in that case it would have to act in the opposite direction.

Some preliminary measurements have been performed by Steven Dufresne using a different thruster, and related calculations and theory can be found on the page fullcylsph.htm. Further related information can be found on page thrusterproject.htm, and the details of practical construction and measurement results are on the page <http://www.entrenet.com/~stevend/efthrusters/fullcyl2d1/fullcyl2d1.htm>. In this case two semi-cylindrical elements of identical dimensions but with two different dielectrics have been molded together, pointing into opposite direction. One semi-cylindrical thruster element opposes the thrust of the other, and since the dielectrics are different, one supposed to overweigh the force of the other and a resultant unidirectional thrust was expected.

Although the measurement is not yet complete, Steven could not measure any resultant thrust upon this thruster during some failed (due to arcing) preliminary measurements using 8 kV.

This result is far from the expected and I still can not understand what would be the correct way of calculating the forces in such a way that the dielectrophoretic and electrostatic pressure forces should exactly cancel each other. With other words it is not clear how could I calculate less dielectrophoretic force than the F_{ycm} on the page [fullcylsph.htm](#) to get zero resultant unidirectional thrust (as Steven's measurement indicates).

Since I have not seen personally any of the above two experiments, can not take any responsibility for their absolute correctness. However, for the present invention it does not really matter whether there is a thrust towards the smaller electrode or no thrust at all. We will assume in the followings that the mentioned measurements are correct and one of these two cases might be true for the drag-neutralizer at the edge of the moving electrode (*fig. 3b*).

Based on the mentioned experimental results there will be no resultant retarding force on the drag-neutralizer semi-cylindrical capacitor element, and the only electrical force component in x direction will be the forward accelerating force F_a at the front edge of the moving electrode. Since this driving force is fairly small and it is insufficient to counteract the frictional forces, a small mechanical driving force will be needed. This mechanical power wasted on friction will be much less than the gained excess energy. **Therefore in this generator the retarding electric forces have been neutralized and it will produce more output electric energy than the sum of input electrical and mechanical energies required for its operation.**

The phases of the generator's operation and practical designs

After explaining the basic principle, let us see some practical designs of the discussed generator. Naturally in a practical device there would be several stator and rotor segments, which can be arranged on discs or cylinders. One possible example using the disc arrangement is shown on *fig. 4* (it shows only one cell without the commutators).

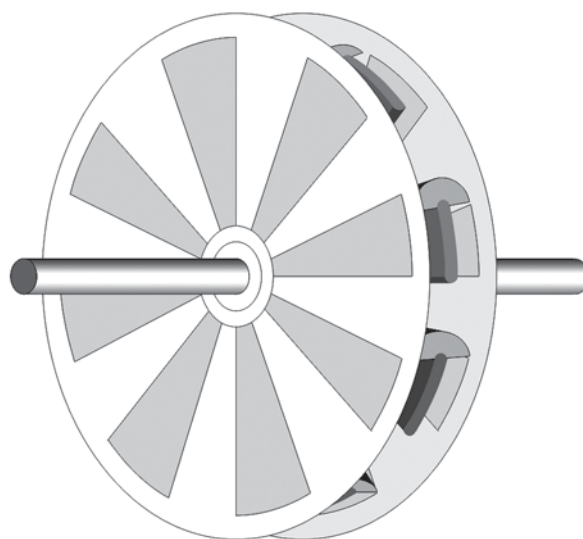

Fig. 4

The working phases are as follows:

1. When the whole surface of the rotor plates is between the grounded stator plates (when the capacitance is maximal, or little before that), an input voltage is connected to the rotor electrodes by suitable input commutators or control electronics (not shown on the drawing). After the plates are charged, the input power supply is disconnected by the commutators.
2. The rotor is rotated in such direction that the drag-neutralizers should be at the aft edges of the moving electrodes (clockwise on the drawing). This rotation will require minimal mechanical power just enough to compensate the frictional losses, since there will be no retarding electrostatic forces to be counteracted. The semi-cylindrical drag-neutralizers will eliminate these forces.
3. When the rotor plates leave the space between the adjacent stator electrodes, i.e. when the voltage potential is at maximum on the rotor electrodes, they are discharged through the output mechanical commutators or other suitable control electronics (not shown). The most efficient operation can be achieved when the rotor electrodes are completely discharged and their complete energy is utilized in each cycle, but this is not absolutely necessary for the operation.

The output energy can be discharged directly into resistors to generate heat, or into suitable capacitor system to reduce the voltage and in-

crease the current (charging in series, and discharging in parallel). A further possibility is to discharge the energy into resonant LC circuits and take off the useful energy through transformers with suitable current intensities. On *fig. 4*, only one generator cell is shown, but several such cells can be mounted on the same shaft to achieve substantial output power.

The available maximum output power will be limited by the speed of rotation and by the maximum output voltage allowed by the electric strength of the insulation between the stator and rotor plates. This insulation can be improved by covering the rotor and/or stator plates with solid dielectric material. However, if the stator plates are coated with thick insulator, then this increases the gap between the rotor and stator electrodes, decreases the capacitance and the output current.

If the rotor segments are coated with thick dielectric, then this would be the most beneficial from electric point of view (increased maximum voltage and output current), but in this case unwanted dielectrophoretic retarding forces might be developed within the thick dielectric layer. This would require additional mechanical driving torque and input power. Thus the optimal arrangement should be found by measurements and experiments.

The number of segments per disc depends on the speed of rotation, desired output frequency, voltage, current, and on other practical considerations. Preferably the output frequency would be best in the 50-60 Hz range, but such low frequency does not allow the generation of substantial output power due to the relatively low achievable capacitance and current. By increasing the frequency the output power can be increased, but then we will have difficulties with the extraction and utilization of high frequencies (except if it is immediately converted into heat in suitable resistors). Thus a compromise should be found here too.

Estimating the output power

Finally let us make some rough estimations how much power could be generated with a practical capacitive generator. Let us suppose that the lowest capacitance between the rotor electrodes and the grounded stator plates is 10 times

smaller than its highest value when the plates completely cover each other.

1. In the first case let us take the radius of the rotor to be $r=0.5m$ and assume to have 8 segments per disc. Then the active surface area of the fully closed capacitor is $S=r^2p=0.79m^2$ (the rotor segments have only half of this area but their both sides are utilized for a capacitor). The air gap between the stator and rotor electrodes is $d=1cm$. This gap allows maximum $30kV$ tension without sparking (or even less due to the edges, but they can be covered with insulator). Since this $30kV$ of max. output voltage is 10 times greater than the input voltage, the input voltage should be $3kV$ or less.

The capacitance of one cell is $C=e_0S/d=6.95E-10F$ and the charge upon the rotor plates is $Q=UC=2.1E-6C$. Since there are 8 segments per rotor disc, there will be $Q_0=8Q=16.8E-6C$ charge transferred to the output at each revolution (the capacitor will be charged and discharged 8 times per revolution).

If the speed of the rotation is $6000\text{ rot/min}=100\text{ rot/sec}$ then the output current will be $I=Q_0 \cdot 100\text{ rot/sec}=1.68E-3C/sec=1.68\text{ mA}$. The output power of one cell is $P_1=30kV \cdot 1.68mA=50.4W$. By mounting 100 such cells on the same shaft we can get 100 times greater **output power i.e. $P_0=5kW$** .

If the thickness of one cell is $3cm$ then the dimensions of such a generator would be $1m \times 1m \times 3m$ taking about $3m^3$ of rectangular volume.

2. In the second case $r=1m$ thus $S=3.14m^2$. There is $d=2cm$ air gap between the electrodes and 8 segments per disc. This allows $60kV$ maximal output voltage and about $6kV$ input voltage.

The capacitance of one cell is $C=1.39E-9F$, and it can store $Q=8.34E-6C$ charge at $6kV$. The total charge transferred in one revolution is $Q_0=8 \cdot Q=6.67E-5C$. If the rotational speed is $12000\text{ rot/min}=200\text{ rot/sec}$ then the current is $I=13.34mA$. This current gives $P_1=800W$ power at $60kV$. By mounting 50 such cells on the same shaft the total **output power will be $P_0=40kW$** . With a cell thickness of $5cm$, this generator would have a dimension of $2m \times 2m \times 2.5m$ taking a rectangular volume of $10m^3$. With a positive feedback the electrical and mechanical input power can be acquired

from the output and the device can be made self-sustaining.

Although theoretically any amount of power could be achieved with such generators, there is a practical limit in increasing the diameter and the speed of rotation. When the diameter and the speed of rotation is too high, huge centrifugal forces will appear that can break apart the rotor. At the same time the danger of vibrations will be great and high precision machining will be required to minimize this effect. Thus if anyone ventures to make such generators, he should first consult a machine

engineer to perform the necessary calculation for the mechanical stability of the device and follow his design (to prevent the mechanical explosion of the rotor).

A further problem is that in such cases the friction of the air will increase to a considerable level and diminish the efficiency of the device. This can be avoided by evacuating the sealed chamber in which the rotor is spinning. There are some other more practical ways of increasing the performance and the output power, but those methods will be discussed on a separate page later.

Moon Colonization and Alternative Energy Technologies



Plans for the colonization of the Moon, announced by the President of the USA, have clear commercial goals. In 20–30 years oil and gas will no longer be used as sources of energy. Scientists and politicians of all countries pin their hopes on thermonuclear fusion, the ideal fuel for which is Helium-3. In the opinion of Academician Halimov, extraction and transportation of Helium-3 from the Moon could become the most promising and profitable means of energy generation (as reported in his speech “Problems and Prospects of Exploration of the Moon and Other Planets” given at a session of the Russian Academy of Sciences Presidium held on December 23, 2003).



an online and published
magazine about Electric,
Hybrid, Fuel Cell Vehicles,
advanced batteries, ultra
capacitors, fuel cells,
microturbines, free energy
systems, events and
exhibitions worldwide

63600 Deschutes Mkt Rd,
Bend Oregon, 97701

541-388-1908

fax 541-388-2750

etimes@teleport.com

www.electrifyingtimes.com

Subscription \$13/3 issues

GFE

Gesellschaft zur Forderung Freier Energy (Society for Development of Free Energy Technologies)

A non-profit organisation committed to making use of new regenerative sources of energy of inexhaustible availability.

Merkurring 100

D-22143 Hamburg / Germany

Tel. +49(0)40-679 459 12

Fax. +49(0)40-679 459 59

Internet: www.gfe-hamburg.de

E-mail: K.Jebens@Jebens-Gruppe.de

BEGINN
(www.beginn.biz)

The Bergedorf Society of Innovations contributes to our development work with regard to the radiation/energy converter in supplying the know-how of their physicists, researchers and engineers.

About GFE — who are we?

Klaus Jebens, President and CEO of the GFE, son of Heinrich Jebens, inventor and president of the “Deutsches Erfinderhaus” in Hamburg, has established the “Jebens Group of Companies” a few decades ago and has since been successful in business and as an inventor with 63 patents to his name.

Dirk Schadach, Head of Development, masters degree in physics, special emphasis on applied physics of electromagnetic fields including EMC. Professional career in the fields of the electric energy technologies, fuel cell applications, establishment of private research institutes in the areas of Frankfurt (1999–2000) and Berlin (2002–2003)

The Development + Research Team /GFE consists of a group of approx. 10 scientists and engineers who back this society and do not publicise their work. Due to this teamwork it was possible to register a first patent in 2003.

Schedule of Development. History

In November 1930 Heinrich Jebens travelled to America on the invitation of T.A. Edison and other inventors and was asked by Nicola Tesla to join him on a test ride of a newly developed car which was driven on “radiant energy”. This test ride proved to be an overwhelming success.

The Development Work of GFE

Research and evaluation of old and new publications and essays concerning inventions and scientific work on innovative energy conversion technologies worldwide.

Undertaking investigations into all promising methods by which it might be possible to gain access to new sources of energy and convert these into electric power.

Construction of working models (incl. specified documentation) to test the efficiency of such energy converters in the laboratory, followed by improving adjustments and finally the construction of prototypes that live up to present day levels of technology with a view to operating efficiency, durability and economic life time, security in operation and exclusion of possible health risks.

One basic patent for the radiant energy converter (name TSEK) has been filed as a result of several years' development work, specified amendments to follow.

Innovative Energy Technologies

The primary objective of our work is the utilization of such energy as was discovered more than 100 years ago by Nikola Tesla and was referred to by him as "radiant energy" or "radiations". Since the late 30s of the past century this discovery was neglected and almost forgotten.

Since that time the world's population has quadrupled to some 7,000 million and the number of cars worldwide has risen to nearly 1,000 million. To supply the energy for our population and vehicles we basically rely on fossil fuels which over the next 25 years will be increasingly in shorter supply and therefore become more and more expensive.

It is now foreseeable that the oil reserves will run dry within 50 to 70 years and remaining oil reserves should remain for the use in the chemical industries. Bearing this in mind we are addressing the task of solving these impending (energy) problems.

All other known regenerative energy sources can only supply a small portion of the energy needed and even if extensively promoted could not supply more than 25% of total energy needs. Nuclear energy should be discarded in steps as quickly as possible due to the problems of its waste disposal and the general danger.

So, how do we go on in future?

Make use of *INNOVATIVE ENERGY SOURCES*; for which pioneers have prepared the path over the last 150 years.

Space Energy and Radiations

The space around us is full of potential energy and noncoherent high frequency electro-magnetic energy from a natural source which we cannot utilize at present. We call this source of inexhaustible energy simply "space energy" which is available in space everywhere like a sea of endless energy.

Now, so far we have looked at this source from the wrong side and this is the reason why our established researchers have not found a way of gaining access to it.

It is the declared aim of the GFE to find a way of utilizing this inexhaustible source of energy and convert it to electric power. Some scientists and inventors, such as Nikola Tesla, Thomas H. Moray and Hans Coler, have already mastered this task with working prototypes decades ago and have then taken this secret with them to their graves.

Apparently, at that time mankind was not ready for a change to such breathtaking new technologies which tended towards an infra-structure of decentralised energy supply. Fragments of these discoveries still available have been incorporated into the development and research work done by GFE.

Future Advantages

- **Low Cost Energy** tapped from this inexhaustible source in the universe (vacuum field, zero point energy, space energy) this energy will be converted to electric power or directly into mechanical energy by means of a converter, called The Radiant-Energy-Converter.
- **Protection of the Environment and Climate.** Reduction of CO₂ – emission Reduction of nuclear power. Saving fossil fuels.
- **Reduction of Electro-Smog.** High current overhead power lines can be reduced step by step as small businesses and private households change their energy supply to decentralised systems. Only for big industrial users requiring more than 1 MW would power stations and overhead power lines be required.
- **A Better World.** The poorer population in the third world and development countries with their emerging markets will also benefit from this new technology, offering them affordable low cost energy for a number of development projects (i.e. water supply and distribution to desert areas, etc.).

New Energy Converter Invented

A new device for generating energy based on new physical principles has been proposed by a Moscow inventor, **IGOR GLEBOVICH BOGDANOV**.

A new apparatus for the generation of energy based on new physical principles has been constructed by a Moscow inventor. Igor Glebovich Bogdanov is the author of this device. It is intended for the creation of power sources for vehicular stations operating on various types of transport. The device can be used on aircraft, seagoing ships and also for the construction of electric power stations operating on new physical principles. According to Bogdanov's opinion, a constituent part of his system may be used for the realization of a controlled nuclear fusion reaction. His machine contains a rotating device comprising a stator and a rotor. The latter contains a rotated liquid.

Patents: RU 2203518 C2 of 04.27.2003, Bulletin №12, Bogdanov I.G.
RU 2200875 C2 of 03.20.2003, Bulletin № 8, Bogdanov I.G.

Contact information: Bogdanov I.G. Stary Guy Str., 6-1-151, Moscow
Russia, 111402

JNET

New Energy Technologies
A collection of articles Japanese Version
A collection of articles from New Energy Technologies
magazine, 2001–2002 has been published in Japan

To purchase the book, please, contact
Eiichi Yamamoto
President of Yama Trans Co. Ltd

e-mail: admin@yamatrans.co.jp or
eyama@yamatrans.co.jp

A “Confined B-field” Homopolar Dynamotor

Jorge GUALA-VALVERDE¹

and Pedro MAZZONI²

E.mail: fundacionjuliopalacios@usa.net

Abstract

Following our investigation of motional electromagnetic induction started in this journal [1], we search for torque location in “*confined B-field*” homopolar dynamotors. Angular momentum conservation precludes a local interaction between the magnet creating the field and a current carrying wire, as happens in the “*open B-field*” configurations formerly investigated. Angular momentum balance takes place now between the active current and the magnet plus the yoke as a whole.

Electromotive Force due to Spinning Magnets

As advanced in 2002 in this journal [1] and widely published subsequently [2, 3, 4, 5, 6, 7, 8, 9, 10], a spinning magnet induces a Lorentz-type electric field responsible for a motional Hall effect [11] in the bulk of nearby conductors (figure 1).

The figure corresponds to a clockwise north pole magnet rotation beneath two conduct-

ing wires: a *probe* and a *closing (circuit) wire* at rest in the lab. In both the above pieces electrons move centripetally. Each wire becomes an electromotive force (emf.) source. If the ends of the wires are connected, the whole circuit behaves as two identical emf. sources connected in opposition and current cannot flow. If, enabling electrical continuity between the wires, the probe is anchored to the magnet, then direct current (DC) flows through the whole circuit [1, 2]. When the probe is at rest relative to the magnet, induction only takes place on the closing wire, which is in motion relative to the magnet. The probe plays a passive role: to provide a current path [1, 2, 3].

The above experimental discovery, in full agreement with Weber’s electrodynamics [12, 13], puts an end to frequent misconceptions concerning motional electromagnetic induction [14, 15, 16, 17, 18] and gives some credit to “rotating field lines” advocates [19].

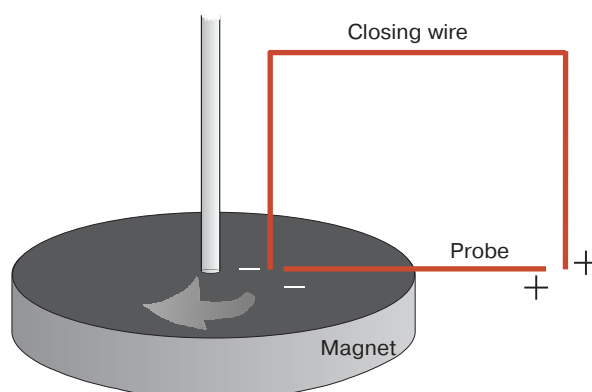

Fig. 1. Homopolar Setup Magnet, Probe and Closing Wire

¹ Subsecretaria Energía Neuquen Government + Ejército Argentino. Neuquen-AR

² Fundación Julio Palacios. Neuquen-AR

Torque Acting on Magnets free to Spin

The engine sketched in figure 1 exhibits a reversible behaviour: Injecting DC through the electrically connected but mechanically decoupled wires, a motor configuration takes place. Obviously, if the probe is soldered to the closing wire giving rise to a closed loop, torque cancellation precludes both magnet and loop rotation.

“A Confined B-field” Homopolar Motor

A slight variation of our former experiments [1] was developed in order to study the behaviour of homopolar motors when the magnetic field remains confined in an iron core. Figure 2 sketches an iron core, the “yoke” from here on, available to confine the **B-field** generated by a uniform cylindrical permanent magnet able to rotate about its symmetry axis.

Traversing the yoke, collinearly aligned with the magnet shaft, is the left branch of a carrying DC wire loop. Laplace force acts on this left wire but is inefficient for developing rotational torque. Both the upper horizontal branch and the right vertical one are located in a region free of **B-field** actions (neglecting

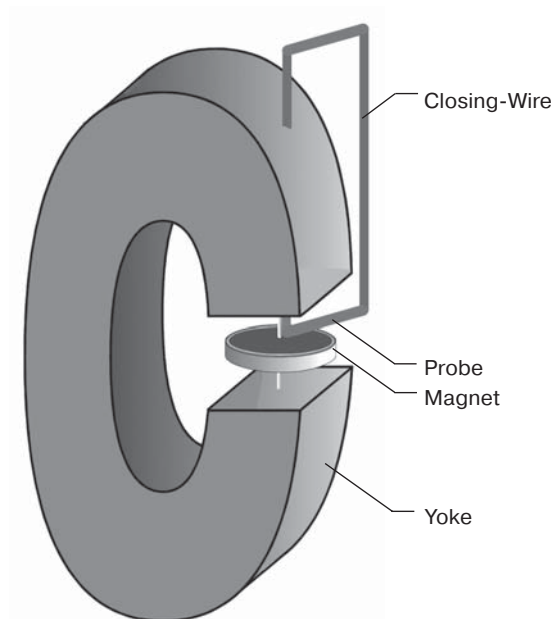

Fig. 2. Confined B-field machine

leakage). The lower horizontal branch, the **probe** from here on, lies in the intense **B-field** region (air gap). The loop itself can be considered as consisting of a probe connected to a closing wire. According to standard electrodynamics, the probe would be the active region for torque generation on the coil and rotation will take place for current sufficient to overcome frictional torque.

A Confined B-field machine

That fact suggested us, in order to enhance the effects, to replace the single loop by a coil of N -loops. In our actual setup the probe “active length” reaches some 4 cm, $N=20$, and the **B-field** on the probe amounts to some 0,1 T.

Whilst coil dynamical behaviour is trivially predicted, the same cannot be said when referring to the magnet. From theoretical considerations we cannot expect continuous magnet rotation, since it would imply angular momentum creation. Due to spatial constraints imposed by the yoke, the coil is unable to describe a full rotation and, after a limited angular excursion, it will collide with the yoke remaining at rest. A continuous magnet rotation would imply the generation of an unbalanced angular momentum, without any identifiable source. Moreover, if we admit the coincidence between kinematical and dynamical rotations [20], we would expect a force interaction between the coil and the magnet plus the core as a whole magnetised bulk. In order to check the above rationale, we have performed the following experiments.

EXPERIMENTAL-1

1-a Both coil and magnet free to rotate in the lab

A (centrifugal on the lower branch) DC ranging from 1 to 20 A is injected in the coil located on the north pole of the magnet.

The predicted torque is observed when DC reaches some 2 A, which suffices to overcome friction on the coil-bearings. As expected, rotation reverses when centripetal DC is injected in the circuit.

Magnet rotation never was detected albeit in our experiments frictional torque on the magnet never exceeded $3 \times 10^{-3} \text{ N.m}$.

1-b Coil attached to the magnet

With the coil attached to the magnet, both co-rotate in the clockwise sense when centrifugal (on the active branch) DC exceeds some 4 A. Motion reverses when centripetal DC is injected. Due to action-reaction cancellation, this experiment rules out a local interaction magnet/coil. The behaviour of the above engine exhibits a strong departure from the equivalent “*open-field*” configuration, and is the first indication that the interaction would take place between the (magnet + yoke) as a whole and the active branch of the coil. With the aim of throw light on that issue we designed and performed two independent sets of experiments.

EXPERIMENTAL-2

2-a Probe and closing wire mechanically decoupled

A *L*-shaped wire is adopted as probe. Both probe and closing wire are electrically connected via mercury beds [1, 3] but mechanically decoupled (figure 3 + photo 1).

The probe is free to rotate in the air gap, whereas the closing wire remains anchored to the bench. When the probe carries a centrifugal DC amounting to some 4 A, then a net probe clockwise rotation is detected. Rotation becomes counter-clockwise when centripetal DC is injected. When DC is raised up to 50 A, no magnet rotation is observed.

2-b Probe attached to the magnet

Probe attached to the magnet, both free to rotate in the air gap. A net clockwise rotation is observed when centrifugal DC reaches some 10 A. Rotation reverses when centripetal DC is injected.

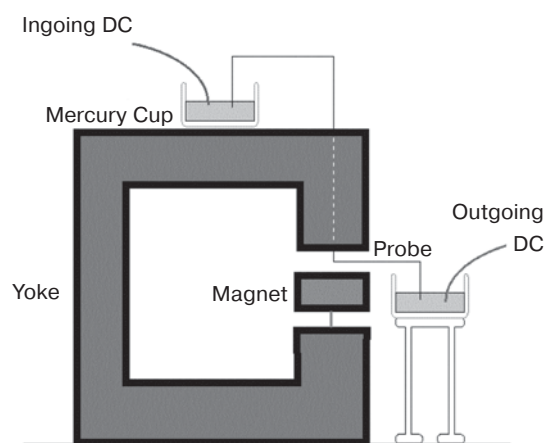

Fig. 3. Setup employed in section 2—experiments

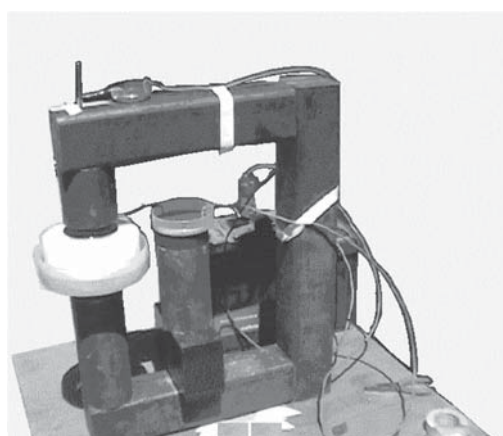

Photo 1. Corresponding to Fig 3

The closing wire, responsible for a magnet rotation in the “*open field*” equivalent configuration, lies now in a field-less region, becoming a passive element for torque generation.

On the other hand, a magnetised body (the yoke in our actual case) is unable to put in rotation another magnetised body (the magnet itself in our actual case). A dragging of the magnet by the probe appears to be the most plausible explanation for the observed phenomenon. In order to give additional credit to the latter hypothesis, we replace the uniform cylindrical magnet by a piece in which a circular sector amounting to some 15° was removed (photo 2). This modification introduces a *short range singularity* in which *B*-field locally reverses [1, 2, 3, 4].

2-c Probe free to rotate in the magnet's singularity

As expected, and due to field reversal, when the probe carries a centrifugal DC amounting to some 4 A, it itself rotates in the counter-clockwise sense, whereas the magnet rotates in the clockwise sense. Clearly, a local interaction in full agreement with Newton's third law takes place in this arrangement.

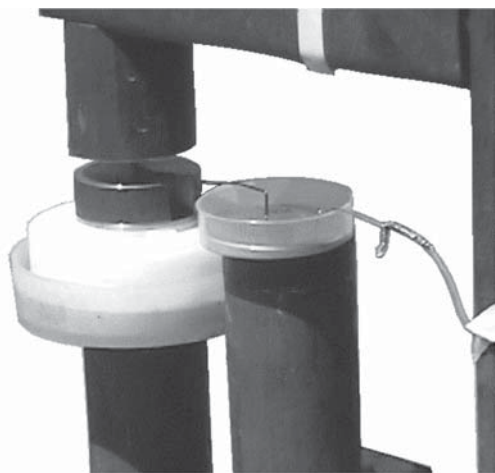

Photo 2. Corresponding to experiments 2-c + 2-d

2-d Probe attached to the magnet in the singularity

No rotation is observed with the probe attached to the magnet when DC as high as 100 A is injected in the circuit, despite the frictional torque being the same as in 2-b. Action-reaction cancellation in the singularity destroys rotational mutual actions between the probe and the magnet. Consequently, this experiment rules out the hypothesis of a "hidden" torque acting on the magnet.

Conclusively, **the active branch of the current carrying loop is the only piece able to drag the magnet.** Our experiments prove that the magnet can no more be the seat of reactive torques, as in the "open-field" configuration. In "confined-field" arrangements, it only plays a passive electro-mechanical role: to provide a magnetic field source. Force interaction is now between the current and the whole magnetised bulk.

EXPERIMENTAL-3

3-a Symmetric counterpart of 1-a

With the aid of two 4 meter steel wires anchored to the ends of its upper branch, the yoke (ca. 80 kg weight) itself was suspended from the ceiling. Fixing the (20 turns) coil in the lab, a counter-clockwise yoke rotation amounting to ca. 1 degree is detected when centrifugal (on the active branch) DC reaches some 50A. Constrained rotation takes place about the line in which lies the magnet axle. This minute effect is easily amplified by optical means. Rotation becomes clockwise when DC reverses.

By attaching the coil to the yoke no angular deviation is detected even for DC as high as 100 A.

"Confined B-field" Homopolar Generator

If the homopolar dynamotor is a reversible engine [1, 2] the conclusions drawn for the motor configuration can be applied, *mutatis mutandis* to a generator configuration:

1. Oscillating Coil

Spatially constrained rotation of the coil delivers a $N\omega BR^2/2$ emf which changes sign when rotation is reversed. The measured output remains unchanged when the coil is attached to the magnet. These qualitative experiments were performed with the aid of a 1000 turns coil manually moved. The output signal was amplified with the aid of a linear amplifier. When, with the coil at rest in the lab, the magnet is spun up to some 5 rps no electrical signal is detected in the coil.

2. Decoupled circuit

We have not performed experiments on generation with the probe mechanically decoupled from the closing wire. Nevertheless, and due to the full reversibility exhibited by electro-

mechanical conversion [1, 2], it is easy to infer the behaviour of each component in an actual engine. We apply, step-by-step, to generation the protocol formerly developed for the motor:

2-a'

If the probe is spun, then it will generate an emf which changes sign when rotation is reversed. Magnet rotation is unable to generate emf.

2-b'

If the probe rotates anchored to the magnet, the same output as in 2-a will be displayed. When dealing with “*confined-field*” arrangements, magnet rotation doesn’t play any active role in emf generation. The above finding gives partial credit to old statements due to Panofsky [16] and Feynman [17], although they were wrong for “*open-field*” configurations.

2-c', 2-d'

Probe in motion relative to the magnet will develop an emf. No emf can be expected when the magnet is spun with the probe attached in the singularity.

FINAL CONSIDERATIONS

Homopolar phenomena have been a troublesome issue for the theory of electrodynamics for almost two centuries [21]. The whole set of experiments performed on both “*open*” and “*confined*” configurations exhibits a common feature: **angular momentum conservation**. Reactive forces, which have their seat on the magnet in “*open*” configurations, “shift” to the whole magnetised bulk when “*confined*” arrangements are employed. The above findings are fully consistent with the Amperian surface-currents responsible for magnetic effects [22]. The source of magnetic field (the magnet itself) **induces** Amperian surface currents on the **whole yoke**, and each of them interacts with the ohmic current traversing the circuit.

A few words on the (in archaic language) “rotating”/“fixed” field-lines controversy can be said in the light of our experiments:

For “*open*” configurations all happens as if ***B*-lines** rotate anchored to the magnet, whereas the above lines appear to be attached to the whole magnetised bulk, when dealing with “*confined*” arrangements.

Unlike the “*open*” configuration, in the “*confined*” one, only an active torque $\tau_{(M+Y),C}$ exists due to the (magnet + yoke) body, acting on the active (ohmic) current C . The active current reacts on the (magnet + yoke) body with the equal but opposite torque $\tau_{C,(M+Y)}$. Total angular momentum remains null: $\mathbf{L} = \mathbf{L}_{M+Y} + \mathbf{L}_C = 0$, which means that $(I\omega)_{M+Y} = -(I\omega)_C$.

Our experiments confirm Muller’s measurements concerning homopolar motional induction, as applied to emf generation [23, 24]. Unfortunately, Muller (as well as Wesley [25]) failed when attempting to rationalize the observed facts. The above due to a misconception about the relevant parts involved in the whole interaction. Muller centered his analysis in the magnet/wire pair, rather than in the (magnet + yoke)/wire one which is, in fact, the physically relevant pair. The Muller/Wesley rationale entails doubts about angular momentum conservation.

APPENDIX. Experimental details

In order to diminish frictional torque on the magnet’s bearings, we developed the contrivance shown in figure 4 and photo 3.

The magnet itself is embedded in a teflon “boat” able to float in a mercury bed. Archimedes push diminishes the apparent weight of the whole piece. Mechanical contact between the magnet and the yoke is achieved with the aid of 4 steel balls “sandwiched” between two circular paths, respectively inscribed in both the contacting faces of the yoke and the magnet. Mercury is added until the magnet smoothly slides on the yoke.

Acknowledgments: To Tom E. Phipps Jr. and Cris Gagliardo for valuable collaboration.

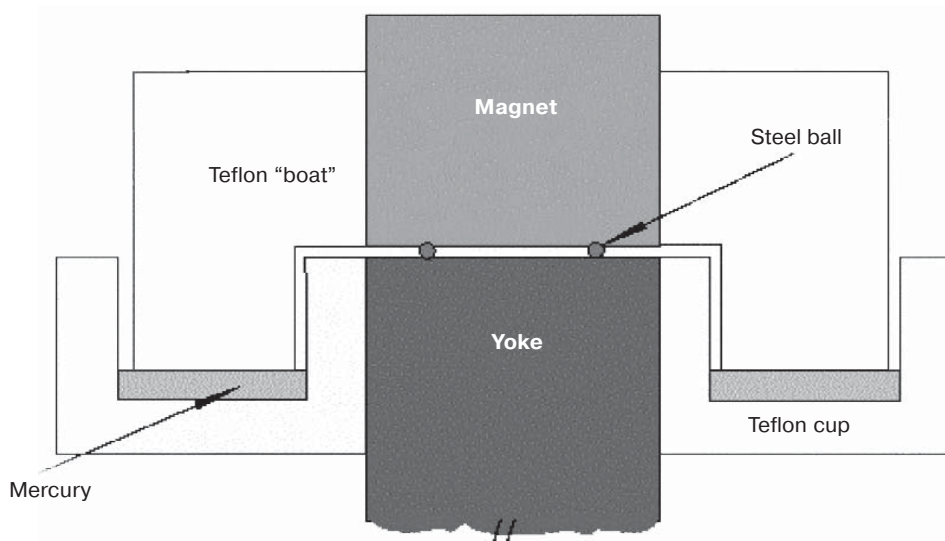

Fig. 4. Contrivance employed to diminish frictional torque on the bearings

REFERENCES

- [1] J. Guala-Valverde, *Physica Scripta* **66**, 252 (2002).
- [2] J. Guala-Valverde & P. Mazzone, *Rev. Fac. Ing. UTA (Chile)*, **10**, 1 (2002).
- [3] J. Guala-Valverde, P. Mazzone & R. Achilles, *Am. J. Physics* **70**, 1052 (2002).
- [4] J. Guala-Valverde, *Spacetime & Substance* **3** (3), 140 (2002).
- [5] J. Guala-Valverde, *Infinite Energy* **8**, 47 (2003).
- [6] J. Guala-Valverde *et al.*, *New Energy Technologies* **7** (4), 37 (2002).
- [7] J. Guala-Valverde, "News on Electrodynamics", *Fond. Louis de Broglie*, in press (2003).
- [8] F.R. Fernández, *Spacetime & Substance*, **4** (14), 184 (2002).
- [9] R. Achilles, *Spacetime & Substance*, **5** (15), 235 (2002).
- [10] G.R. Dixon & E. Polito, "Relativistic Electrodynamics Updated", (2003) www.maxwellsociety.net
- [11] J. Guala-Valverde & P. Mazzone, *Am. J. Physics*, **63**, 228 (1995).
- [12] A.K.T. Assis & D.S. Thober, "Unipolar Induction...", *Frontiers of Fundamental Physics*. Plenum, NY pp.409 (1994).
- [13] A.K.T. Assis, *Weber's Electrodynamics*, Kluwer, Dordrecht (1994).
- [14] E.H. Kennard, *Phil. Mag.* **23**, 937 (1912), **33**, 179 (1917).
- [15] D.F. Bartlett *et al.* *Physical Review D* **16**, 3459 (1977).
- [16] W.K.H. Panofsky & M. Phillips, *Classical Electricity and Magnetism*, Addison-Wesley, NY (1995).
- [17] R. Feynman, *The Feynman Lectures on Physics-II*, Addison-Wesley, NY (1964).
- [18] A. Shadowitz, *Special Relativity*, Dover, NY (1968).
- [19] A.G. Kelly, *Physics Essays*, **12**, 372 (1999).
- [20] A.K.T. Assis, *Relational Mechanics*, Apeiron, Montreal (1999).
- [21] H. Montgomery, *Eur. J. Phys.*, **25**, 171 (2004).
- [22] T.E. Phipps & J. Guala-Valverde, *21st Century Science & Technology*, **11**, 55 (1998).
- [23] F. J. Muller, *Progress in Space-Time Physics*, Benj. Wesley Pub., Blumberg, p.156 (1987).
- [24] F.J. Muller, *Galilean Electrodynamics*, **1**, Ne3, p.27 (1990).
- [25] J.P. Wesley, *Selected Topics in Advanced Fundamental Physics*, Benj. Wesley Pub., Blumberg, p.237 (1991).

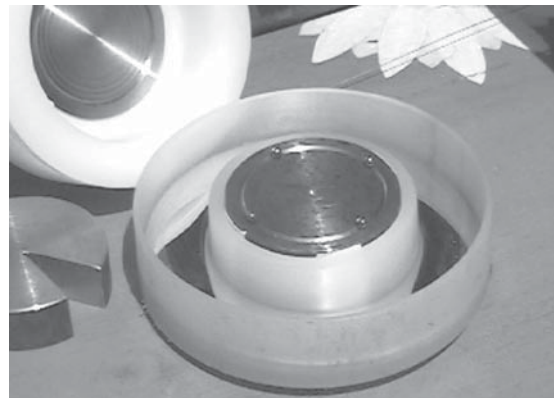

Photo 3. Corresponds to Fig. 4

An Analysis Of The Evaluation Process Of The Electric Energy Consumed By A Hydroelectric Heat Generator

F.M. KANAREV, Krasnodar, Russia
e-mail: kanphil@mail.kuban.ru

We have just obtained approval to apply for patents on high-efficiency devices generating additional heat energy. The time has come to invite other researchers to join our project. The process of adapting this technology will evolve more efficiently if novice researchers know the most crucial problems facing us on our way to commercializing these devices. That is why we have decided to start publishing patented schemes of hydroelectric heat generator cells and explaining the most complicated problems that might hinder the process of their commercialization. The evaluation process of the electric energy con-

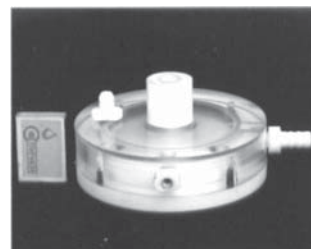

Fig. 1. The cell of a hydroelectric heat generator

sumed by a hydroelectric heat generator in household or industrial conditions is one of the problems. This is why a detailed analysis of the process using real experimental data will be given below.

The evaluation was carried out using a laboratory prototype of the most efficient hydroelectric heat generator cell (Fig. 1). A draft of this cell will be published after a patent has been issued.

A scheme of the experimental installation is shown in Fig. 2.

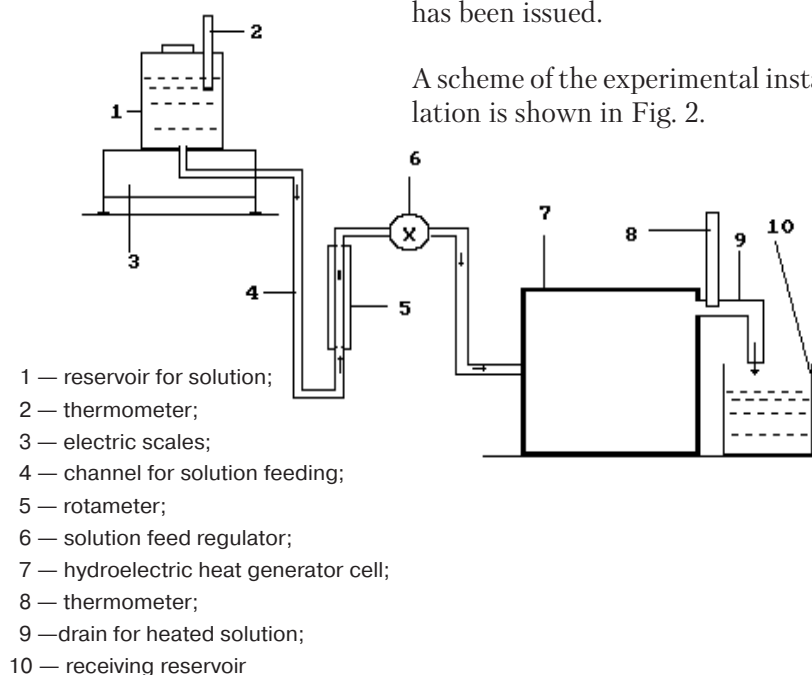

Fig. 2. A scheme of the experimental installation

Table 1

Indices	1	2	3	Avg.
1 – mass of the solution, passed through the cell m , kg.	0.600	0.624	0.600	0.608
2 – solution temperature on the cell input t_1 , degrees Celsius.	21.0	21.0	21.0	21.0
3 – solution temperature on the cell output t_2 , degrees Celsius.	41.0	41.0	41.0	41.0
4 – solution temperature difference $dt=t_2-t_1$, degrees Celsius.	20.0	20.0	20.0	20.0
5 – duration of the experiment $d\tau$, seconds	300.0	300.0	300.0	300.0
6 – voltmeter indications V , volts	5.0	5.0	5.0	5.0
6' – oscillograph indications V', volts	4.8	4.8	4.8	4.8
7 – ammeter indications I , amperes	0.60	0.60	0.60	0.60
7' – oscillograph indications I', amperes	0.60	0.60	0.60	0.60
8 – energy consumption according to voltmeter and ammeter indications $E_1=IVd\tau$, kJ	0.90	0.90	0.90	0.90
9 – heated solution energy, $E_2=3,04 \cdot m \cdot dt$, kJ	36.48	37.94	36.48	36.97
10 – cell energy efficiency $K=E_2/E_1$	40.53	42.15	40.53	41.07

The voltage and the current on the input of the cell of the hydroelectric heat generator were evaluated by two sets of devices: a voltmeter with an accuracy rating of 0.2 (GOST 8711-78), an ammeter with an accuracy rating of 0.2 (GOST 8711-60) and the ASK-2022 electronic oscillograph.

In order to reduce heat losses that were not taken into consideration during the experiment, the temperature differential of the solution before and after being heated in the cell was kept at a considerably low level $dt=21^\circ\text{C}$.

The results of the experiment are set out in Table 1.

Since the energy efficiency of the cell turned out to be high, we decided to back up the voltmeter and ammeter readings with oscillograph readings. Having received the oscillograph records, we turned to a specialist in measuring systems and devices. He had the kindness to assent to help us by studying the oscillograph records and sending us back the results and a description of the processing method. In his letter, he wrote that our evaluation of electric energy on the cell input was absolutely correct. As a token of gratitude we included his name in the list of the authors of our first article, which comprised a description of the approach proposed by him and the results of its implementation.

Since experts in measuring systems and equipment are quite rare, and taking into consideration our specialist's great experience, we treated his opinion with great respect. All our further actions were based on the authority of his recommenda-

tions. The voltage (Fig. 3) and amperage (Fig. 4) oscillograph records, as well as the methods of their handling, are given below.

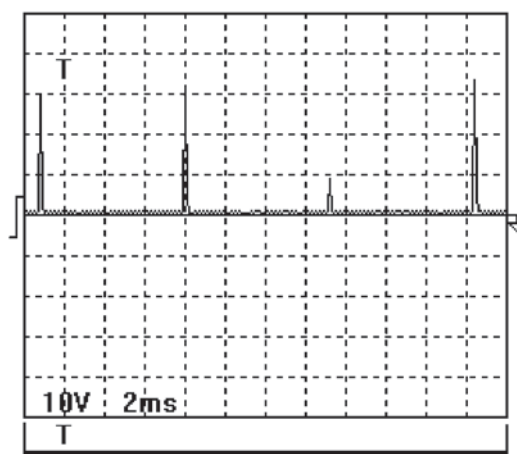

Fig. 3. Voltage

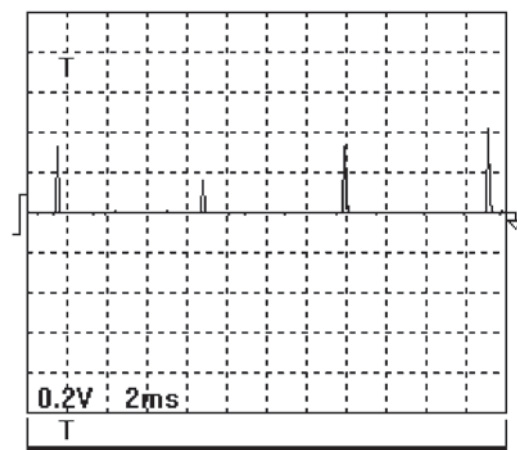

Fig. 4. Current

The impulse scale factor is 10. The average voltage amplitude (Fig. 3) is:

$$U_{a_{\text{avg}}} = (29+31+8+33) \times 10/4 = 252.5 \text{ V.}$$

The amperage was determined as the decrease in voltage in a 0.1 Ohm resistor. Taking this into account, the average current amplitude will be (Fig. 4):

$$I_{a_{\text{avg}}} = (1.7+0.8+1.7+2.1) \times 0.2 \times 10 / (4 \times 0.1) = 31.5 \text{ A.}$$

Impulse repetition interval $T = 7.4 \text{ ms.}$

Impulse length $t_p = 0.28 \text{ ms.}$

Impulse frequency $f = 1000/7.4 = 135.14 \text{ Hz.}$

Intermittency factor $S = 7.4/0.28 = 26.43.$

Impulse duty factor $Z = 0.5/26.43 = 0.019.$

Average impulse voltage value

$$U_{\text{avg}} = 0.019 \times 252.5 = 4.80 \text{ V.}$$

Average impulse current

$$I_{\text{avg}} = 0.019 \times 31.5 = 0.60 \text{ A.}$$

It follows from the data that the divergence between the voltmeter, ammeter (Table 1) and oscillograph does not exceed 5%. This fact was a strong reason to consider the data obtained to be correct.

However, later on, the author of the proposed method announced that he had begun to doubt whether the method used to evaluate the energy consumed by the cell of a hydroelectric heat generator was entirely correct.

In this situation I, being the scientific advisor of the present research, had to perform a detailed analysis of the evaluation process of the energy consumed by the hydroelectric heat generator cell. The results of this analysis are given below.

In order to simplify the process of analysis, a scheme that can be called structural was developed (Fig. 5). In addition to the data set out in Table 1, the voltage and current ahead of the impulse generator were evaluated (Fig. 5, Pos. 3) during the experiment. The voltage at that point equaled the voltage in the mains (220 V). The amperage remained permanent and amounted to 0.60A.

The average voltage value 5.0 V and average amperage value 0.60 A (Fig. 5) on the input of the cell of a hydroelectric heat generator (1) are inscribed into the schematic symbols representing

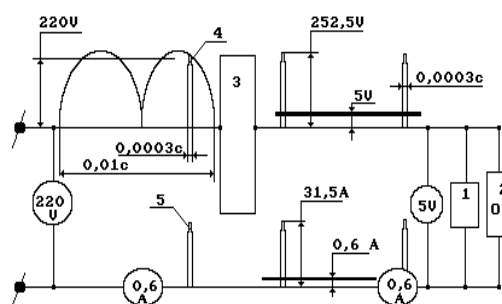

- 1 – hydroelectric heat generator cell;
- 2 – electric oscillograph;
- 3 – impulse generator;
- 4 – voltage impulse;
- 5 – current impulse; other circuit components correspond to the agreed notation.

Fig. 5. A scheme of the evaluation of hydroelectric heat generator electric parameters

the voltmeter and ammeter.

The average voltage impulse amplitude amounted to 252.5 V, the average voltage value being 5 V. The average current impulse amplitude amounted to 31.5 A, the average current value being 0.60 A (Fig. 5). The impulse duration amounted to 0.00028, the intermittency factor and impulse duty factor being 26.43 and 0.019 respectively.

According to the voltmeter, ammeter and oscillograph readings, the power on the cell input averages $P_0 = 5 \times 0.6 = 3.0 \text{ W.}$ Taking this into consideration the cell's energy efficiency will be $41.07 \times 100 = 4107\%$ (Table 1). The same result is obtained during the processing of the oscillograph records.

It is known that the evaluation of voltage and current in electric circuits with complicated impulses (Fig. 3 and 4) by oscillograph is considered to be the most reliable method, yet not the most precise. That is why oscillograph readings that differ from back-up voltmeter and ammeter readings by no more than 5% are considered to be indisputable. This is a reason to conclude that the index of energy efficiency of processes taking place inside the cell of a hydroelectric heat generator amounts to 4000%.

In order to be absolutely sure of the result obtained, the voltmeter, ammeter and oscillograph readings must be backed up by another, more precise indicator. One indicator is an electronic energy counter, which that we do not possess. How-

ever, knowing its working principle, we can theoretically calculate the final result of its evaluation.

First of all, an electronic counter will register the energy of every impulse. Since the energy is proportional to the pulse area, the electronic energy counter will separately determine the area of every voltage and current impulse (Fig. 3 and 4). Then, let us assume that the areas of voltage and amperage impulses obtained will be multiplied by the number of impulses per experiment $(300/0.0074)=40540.54$. After this, the multiplication of the total voltage impulse area by the total current impulse area will show the amount of energy consumed by the cell (1). Taking into consideration a triangle shape of impulses, we get the following:

$$\begin{aligned} &\text{Voltage impulses area} \\ &252.5 \times 0.5 \times 0.00028 \times 40540.54 = 1418.92 \end{aligned}$$

$$\begin{aligned} &\text{Current impulses area} \\ &31.5 \times 0.5 \times 0.00028 \times 40540.54 = 178.38 \end{aligned}$$

According to this method of registration of the energy consumed by the cell of a heat generator, the amount of energy will total $E=1418.92 \times 178.38=253.1$ kJ. This result is obviously incorrect as it exceeds the readings of the devices connected before the impulse generator $220 \times 0.6 \times 300=39.6$ kJ. Where is the mistake? In order to find it, we have to calculate the same energy using the voltage and current impulses in order to determine the power generated by the cell. The total voltage and current impulse areas per second have to be found and then multiplied together. The number of impulses per second equals a frequency of impulses of 135.14 Hz. Then the total area of voltage impulses per second will be $252.5 \times 0.5 \times 0.00028 \times 135.14=4.78$ V. The total area of current impulses will amount to $31.5 \times 0.5 \times 0.00028 \times 135.14=0.60$ A. One can see that these values agree with those obtained during the processing of the oscillograph records. Then, the power generated by the cell will total $4.78 \times 0.60=2.87$ W while the energy consumed by it from the mains will be $2.87 \times 300=0.86$ kJ. The energy efficiency of the process will be $36.97/0.86=42.50$. Connecting a voltmeter and ammeter before the cell, allow us to confirm the result obtained. In Table 1 this value equals 41.07.

Now it is much easier to answer the question of why the devices connected before the impulse genera-

tor (3) indicate that the impulse generator and the cell together consume 39.6 kJ during the experiment, while taking into consideration all voltage and current impulse area results in the value 253.1 kJ?

In order to do so, let us pay attention to the fact that, as follows from Fig.5, the value of the current is common for the whole circuit, while the voltage values differ. The voltage before the impulse generator (3) totals 220 V, while the voltage ahead of the cell and after it leaves the impulse generator is 5 V. This means that during the calculation of the power consumed by the cell, performed by means of evaluating the voltage and current areas, we need to take into consideration the total area of voltage impulses only and then multiply this area by the value of current common for the whole circuit, i.e. by 0.6 A. Then we will have $252.5 \times 0.5 \times 0.00028 \times 0.6 \times 41095.98=0.87$ kJ. The energy efficiency of the process will amount to $36.97/0.87=42.50$.

Thus, if we calculate the energy consumed by the cell by means of an electronic energy counter, connected before the cell, we shall get the same result as obtained by studying the voltmeter, ammeter and oscillograph readings.

This is enough evidence to show that the energy efficiency value of the cell of a heat generator exceeds 4000%. The laboratory results of this index are stable and reliable.

The question arises of whether the existing electrical measuring instruments connected before the impulse generator (Fig. 5, Pos. 3) can confirm the present efficiency

As one can see from Fig. 5, at an efficiency factor of the impulse generator equaling or approximating unity, an ammeter connected ahead of the impulse generator (3) will indicate 0.60A, and a voltmeter will indicate 220 V. As a result, the power generated by the impulse generator (3) and the cell (1) will total $P_1=220 \times 0.60=132$ W. In this case, the energy efficiency of the cell of a hydroelectric heat generator, taking into consideration the heated solution energy (Table 1) will be less than unity $(36970/300=123.23)/132=0.93$.

Thus, if the efficiency factor of the impulse generator (3) equals unity, the readings of the devices connected before and after the impulse generator, are forty times greater. The question is: which measuring instruments permits us to reveal the result matching the true amount of energy consumed by

the cell of a hydroelectric heat generator? Those connected before the impulse generator (3) or those connected after it? What is the physical essence of the difference between the two aspects?

In order to answer this question, we need to pay more attention to the physical processes that take place during the evaluation of the voltage and current before the impulse generator (3).

The readings of the voltmeter connected before the impulse generator (3) exceed those of the oscillograph and the voltmeter connected before the cell (1). This happens because the voltage ahead of the impulse generator always equals the voltage in the mains, 220 V.

Let us pay attention to the fact that a single impulse (100 Hz) of rectified current with a duration of 0.01 sec is shown before the impulse generator in Fig. 5. A voltage impulse (4) with a duration of 0.0003 sec., which is detached by the impulse generator from the whole impulse with a duration of 0.01 sec and directed to the cell, is also shown in Fig. 5. Strictly speaking, the remaining area under the curve of the rectified impulse with a voltage of 220 V must decrease by a value corresponding to the area of the impulse sent to the cell and correspond to a voltage of $220 - 5 = 215$ V. However, this difference is compensated for by the mains potential while the indicated area of the impulse with a duration of 0.01 sec. still corresponds to a voltage of 220V.

Thus, any measuring devices connected before the impulse generator (3) will register power 40 times greater than the devices connected before the cell (1). Now we know that the reason for this is that the devices connected before the impulse generator (3) attribute a current of 0.60 A not to the magnitude of the voltage impulse (with a duration of 0.0003 sec.) sent to the cell of a hydroelectric heat generator, but to the whole voltage impulse (220V) with a duration of 0.01 sec.

It is only now that we may try to answer another question of whether the efficiency obtained can be applied in household or industrial conditions with the aim of achieving energy economy?

Since an electric circuit represents a closed system, a current of 0.6A will flow through all electric pulse counters installed in the system (with a voltage of 220 V) all the way up to the electric power station generator's turbine. As a result, all counters will register the power created by the

impulse generator (3) and the cell (1) together, i.e. 132 W. Such are the features of electric circuits. No energy economy is possible.

Thus, we have two contradicting results: the undisputable energy efficiency of the hydroelectric heat generator's cell totaling almost 4000% and the inability of an electric circuit to make use of the effectiveness to economize energy. The main cause for this contradiction lies in the fact that the cell consumes energy in the form of short-term voltage and current impulses, which are not present in the mains.

But what if we turn down the idea of using an impulse generator and design an electric energy generator that will create energy in the form of impulses used by the cell (Fig. 3 and 4)? Evidently, such a generator must not have any electric communication with the whole electric circuit. In this case, a power of 3.0 W generated by the cell will be directed to the generator shaft. If we make the shaft common with the shaft of an electric motor setting the generator in motion, the common shaft will create a power of 3.0 W for the cell. The power drawn by the electric motor from the common circuit will be (taking into consideration any losses) the same.

Summary

A voltmeter, ammeter and oscillograph connected before the cell of a hydroelectric heat generator correctly evaluate the energy consumed by the generator.

The energy efficiency of the cell of a hydroelectric heat generator, amounting to 4000%, is registered in laboratory conditions as stable and reliable.

The high-energy efficiency of a hydroelectric heat generator can be implemented in modern electric circuits by using an individual generator creating electric energy in the form of the voltage and current impulses consumed by the hydroelectric heat generator.

REFERENCES

1. Kanarev Ph.M. The Principles of Micro World's Physical Chemistry. Third edition. — Krasnodar: KSAU Publishers, 2003. <http://Kanarev.innoplaza.net>
2. Kanarev Ph.M. The Principles of Micro World's Physical Chemistry. Fourth edition. 2004. (In English). <http://Kanarev.innoplaza.net>

Conversion Of Environmental Energy

B.M. KONDRASHOV

Moscow, Russia.

e-mail: kbm@land.ru

In the present article are considered ways of low-potential energy conversion, making possible the generation of power, high-grade heat and "cold". They involve the use of scientifically valid and experimentally proven technical solutions, which are realized in ejector-nozzle devices of turbine engines. Unlike known free energy converters (using wind or solar energy), the effectiveness of environmental energy conversion in the fuel-free turbine discussed below engines does not depend on geographical, temporary or atmospheric conditions, while their power density is higher and could be compared with the power density of traditional heat engines. They may work either by using an open cycle and atmospheric air as the working medium, or by using a closed cycle in air-independent systems. The generation of the needed energy type by the fuel-free systems based on such turbine engines is performed directly in the place where it is being consumed. The absence of materials and devices connected with fuel usage in their construction makes the work more fail-safe, simplifies the construction and technology, reduces costs and enables these devices to be produced at most engineering plants, making the operation environmentally friendly.

The problems concerned with keeping up with society's growing energy needs are becoming more acute with each day. The reduction of hydrocarbon raw material reserves and the increase in energy consumption accompanied by the ever-worsening environmental situation require more effective and clean energy conversion technologies, because the existing ones are still not effective. The

uneven heating of atmospheric gases, accumulating solar energy and compressed under the influence of gravity, causes atmospheric pressure changes, affecting the balance of the atmosphere. During its reestablishment, both potential and heat energy of air masses are transformed into kinetic energy. **The transformation of atmospheric energy into the type that allows it to be used, is performed in this stochastic process.** The advantages of windmills using this type of energy over heat-engines lies in the performing of mechanical work without any oxygen consumption and in the absence of exhaust gas production, while the disadvantages are: low energy density per working square unit and the inability to control wind velocity.

However, it is possible to break the atmospheric balance in order to transform the potential energy of air masses into kinetic energy by means of controlled local impacts (for instance, in ejector-type devices). By recreating the equilibrium broken by the active jet of the working medium, the atmosphere performs mechanical work, the amount of which depends on the degree, the method of impact and the parameters of the ejector devices as well. In the ejection process representing parallel adjunction to the stationary reactive jet, the efficiency factor and the additional mass adjunction coefficient m (characterizing the adjoining air mass to active jet ratio) are low because mixing and friction reduce the active jet speed C_{aj} . As a result, both the thrust and the kinetic energy of the reactive mass increase insignificantly.

In another process, that of consecutive adjunction (having another physical basis, which is not necessarily related to jet mixing), the impact of the pulsing active jet creates negative pressure in the ejector muzzle,

when due to the unbalanced atmospheric pressure force air is adjoined and accelerated following each new active jet impulse. **The process can take place practically without mixing the adjoined masses and reducing the active jet velocity**, but only in a limited range of values and correlations of such main process parameters as design frequency, shape, duration, the velocity of active jet impulses, the speed of the approach flow, and the correlation of design values of the jet device and its ejector muzzle.

During the process of adjunction the following combined reactive mass is obtained:

$$TM = 1+m,$$

where **1** is the active jet mass and **m** is the adjoined mass, numerically equaling the adjunction coefficient **m**.

The effectiveness of the process is also characterized by the combined reactive mass velocity coefficient:

$$w_{tm} = C_{tm}/C_{pj},$$

where C_{tm} is the velocity of the combined reactive mass (C_{tm} equals C_{aj} , which depends on the periodical pressure alteration inside the ejector muzzle); C_{pj} is the velocity of the pulsing reactive jet, produced by the working medium with the same parameters as observed during the formation of the active jet, but increasing in volume at constant pressure. Let us consider the types of energy conversion taking place inside engines with different thermodynamic cycles.

The first type refers to a jet engine with an ejector nozzle diaphragm and the working medium resulting from the fuel combustion that takes place inside the chamber of recurrent combustion. The process of adjunction in this case is discrete and consists of a pair of consecutive thermodynamic cycles repeated with a predefined periodicity. Each cycle has its own source of energy and working medium. In the first cycle of each period, the energy of the combustion products is transformed into the kinetic energy of the first part of the reactive mass, which moves in the ejector muzzle as a gas piston, creates negative pressure, and on its outflow acts on the turbine blades, thus creating angular momentum on the axle. Due to the negative pressure in the muzzle, both the potential and thermal energy of the atmospheric air, compressed by gravity, become the main source of energy during the second cycle. Under the influence of the difference in pressure this low-grade working medium expands and accelerates with a drop in temperature (**the difference between a natural stochastic process and the process being de-**

scribed is that the latter can be guided in a pre-arranged direction with design thermodynamic parameters), forming during the outflow from the muzzle the second part of the reactive mass, which acts on the blades. Due to the acceleration of the adjoined air mass, the pressure falls in the muzzle, thus increasing the potential difference in pressure before the outflow of the active jet impulse of the next period, and, respectively, the kinetic energy of the present impulse. As a result, the negative pressure in the muzzle rises during the second cycle of this period, and the velocity of the air being adjoined also increases. Thus, **the transformation of the energy of a low-grade source during the previous period establishes conditions for the increase of effectiveness of energy transformation of another, high-grade source, in the next period.**

Hence, in contrast to the process of parallel adjunction, when the kinetic energy of the ejecting jet is decreased by means of redistribution of its initial energy on a greater gas mass, **a periodical disturbance of atmospheric equilibrium in the ejector muzzle (under the influence of the active pulsing jet), creates a potential difference in pressure with a preset periodicity, providing for acceleration of the adjoined air masses during the process of equilibrium recreation, which results in an increase of the active jet's kinetic energy.** As a result of this discrete process, the combined mass with increased kinetic energy, acting on the turbine blades, augments the momentum on its axle without additional fuel consumption. This leads to the generation of the same power, while the fuel consumption is a minimum of **m** times, corrected by the w_{tm} value, less than in gas turbine engines of a traditional design.

After the start of the outflow of combustion products, their pressure decreases in the chamber and before the throat of the nozzle. The degree of "rear" part expansion of the gaseous mass decreases in the first cycle and so does its velocity. As a result, a decrease of decompression in the muzzle and a reduction of velocity of the adjoined mass are observed during the second cycle. The "front" part of impulses of the combustion products of the next period extrudes the "rear" part of the adjoined air mass, which has a lesser speed, out of the muzzle. All this results in a partial mixing of separated gaseous masses, which decreases the effectiveness of the whole process. However, experiments have shown that even taking into consideration these losses, the combined reactive mass may have kinetic energy totaling $E_{tm} = 0.5(1+m)C_{tm}^2$, which many times exceeds the active jet's energy:

$E_{aj} = 0.5 C_{aj}^2$. By ejecting atmospheric air by the pulsing jet of combustion products, an increase in thrust totaling 140% was achieved. E_{tm} (taking into consideration the decrease of w_{tm} due to the losses caused by partial blending) is 2.4 times greater than the kinetic energy of the active jet E_{aj} . Thus, the major part of the power, created in this type of energy conversion is generated by means of transformation of both potential energy and low-grade heat of gases, compressed under the influence of gravity, into the kinetic energy of air mass. The effectiveness of such combined jet turbine heat engines should be evaluated by the total **efficiency factor**, which equals the **efficiency factor** of the Carnot cycle, increased by the product of the m and w_{tm} coefficients.

The second type. Experiments have shown that the best value of combustion products C_{aj} resides in the range of velocities which can be obtained by expansion of the compressed working medium without additional heating. Consequently, combustion products can be replaced by compressed air, while the combustion chamber can be replaced by a pneumatic accumulator. On the outflow of air from the pneumatic accumulator, the pressure at the throat of the nozzle remains constant during the cycle. That is why the “rear” part of the gaseous mass of the active jet’s impulses, decreasing the effectiveness of the adjunction process, is not present, which practically excludes the mixing of consecutively moving separated air masses, and, therefore, the losses on their friction. The w_{tm} coefficient becomes greater than unity. Since C_{tm} equals C_{aj} , the kinetic energy of the combined mass will be greater than the kinetic energy of the active jet, i.e. E_{tm} is a minimum m of times greater than E_{aj} . The m parameter, which changes its value in a range from 10 to 50, depending on the parameters of the adjunction process, will exceed the value used in the process with the active jet of the combustion products, other conditions being equal. In order to increase the air pressure inside the pneumatic accumulator, different methods, as well as external energy sources, can be used. The energy needed to mechanically compress the air (ignoring compression losses), amounts to E_{aj} and ranges from only 1/10 to 1/50 of E_{tm} .

Such **an energy balance allows compressing of the working medium by using the power generated in the processes of transformation of atmospheric energy into mechanical work during the previous cycles.**

Unsophisticated mathematical calculations show that it is sufficient to increase E_{tm} , obtained in the transformation processes by 44% in comparison with E_{aj} in order to provide for their self-maintenance. Surplus energy can be used by external consumers. If the value of the m parameter amounts to just 1, while the efficiency factors of the turbine and the compressor are 0.85 and 0.8 respectively, **the energy obtained in the previous cycles can be used for the compression of the working medium**, leaving 24% of the available E_{tm} .

Results of experiments have proven the possibility of atmospheric energy transformation during compression of the working medium at the expense of the power generated during its transformation in the previous cycles. When we extrapolate the increase of the kinetic energy by a factor of 2.4, experimentally obtained in a less effective process of the consecutive adjunction of combustion products to the active jet, to a similar process which uses compressed air to create the jet, the energy left for external consumers (taking into consideration losses and compression expenses) will be not less than 34.2% of E_{tm} .

According to the second law of thermodynamics, not all the energy of a single source is transformed into work in the proposed method – part of it is transformed into the heat of losses and into a high-grade heat during the mechanical compression of the working medium. This heat can be dispersed in the environment or used by consumers, which makes it possible to generate power at the same time. The temperature of the heat can be regulated depending on the degree of working medium compression and on the degree of its cooling before expansion. At the atmospheric temperature, the C_{aj} and C_{tm} values will reside in a range of the velocity coefficient π up to 2.45, which is sufficient enough to reach peripheral velocities, providing for a high **efficiency factor** of the turbo-machines.

The air temperature in the processes of energy conversion falls. By controlling the volume of both the atmospheric air and the cold air on the exhaust, which are returned to ejector nozzles as adjoined masses, we can obtain air temperatures that can be used in air-conditioning systems. If the cold air of the exhaust, coming from one ejector nozzle is directed as adjoined masses to another ejector nozzle and so on, it can be cooled down to the extremely low temperatures used in cryogenic devices.

Thus, **the atmospheric energy is simultaneously transformed into three types of energy, that is:**

mechanical energy, high-grade heat energy and into the “cold” of a design temperature.

This type of energy conversion uses open cycles. The exhaust gaseous mass is expelled into the atmosphere. It is cold and does not contain combustion products. The main energy sources are the low-grade temperature of atmospheric air and the gravity that creates the atmospheric pressure. The mechanical compression is performed at the expense of the power, generated during the atmospheric energy conversion, which takes place in previous cycles. That is why the devices, using the present method, are called ***atmospheric (gravitational) fuel-free heat jet engines***. Unlike the known free energy converters (using wind, solar or geo-thermal types of energy), the effectiveness of energy conversion in the proposed engines does not depend on geographical, temporary or atmospheric conditions, while their power density is higher and can be compared with the power density of traditional heat engines. The absence of materials and devices concerned with fuel usage in their construction makes the work more fail-safe, simplifies the construction and technology,

reduces production costs and expands the area of application due to the simultaneous generation of three types of energy.

Let us consider additional ways of increasing the effectiveness and expanding the field of application of fuel-free engines using the following engine as an example (Fig. 1).

The engine consists of an ejector nozzle block, which comprises a convergent propulsive nozzle 1 and an ejector muzzle, the adjoining device 2. The air-gas channel of the device and of the turbines 3 and 4, mounted at the ends of the power shaft 5, is situated inside this hollow shaft. The compressor rotors 6, 7 are located on the outside surface of the shaft. The output of the compressor stage 30, which is not mounted on the shaft 5, is connected via its return valve 20 to the pneumatic accumulator 18 of the working medium. The compressed air is fed into the accumulator through the valves 19 or 20. The valve 21 provides for the design periodicity and for the duration of the out-flow of the compressed air from the propulsion nozzle 1. Negative pressure forms in the device 2

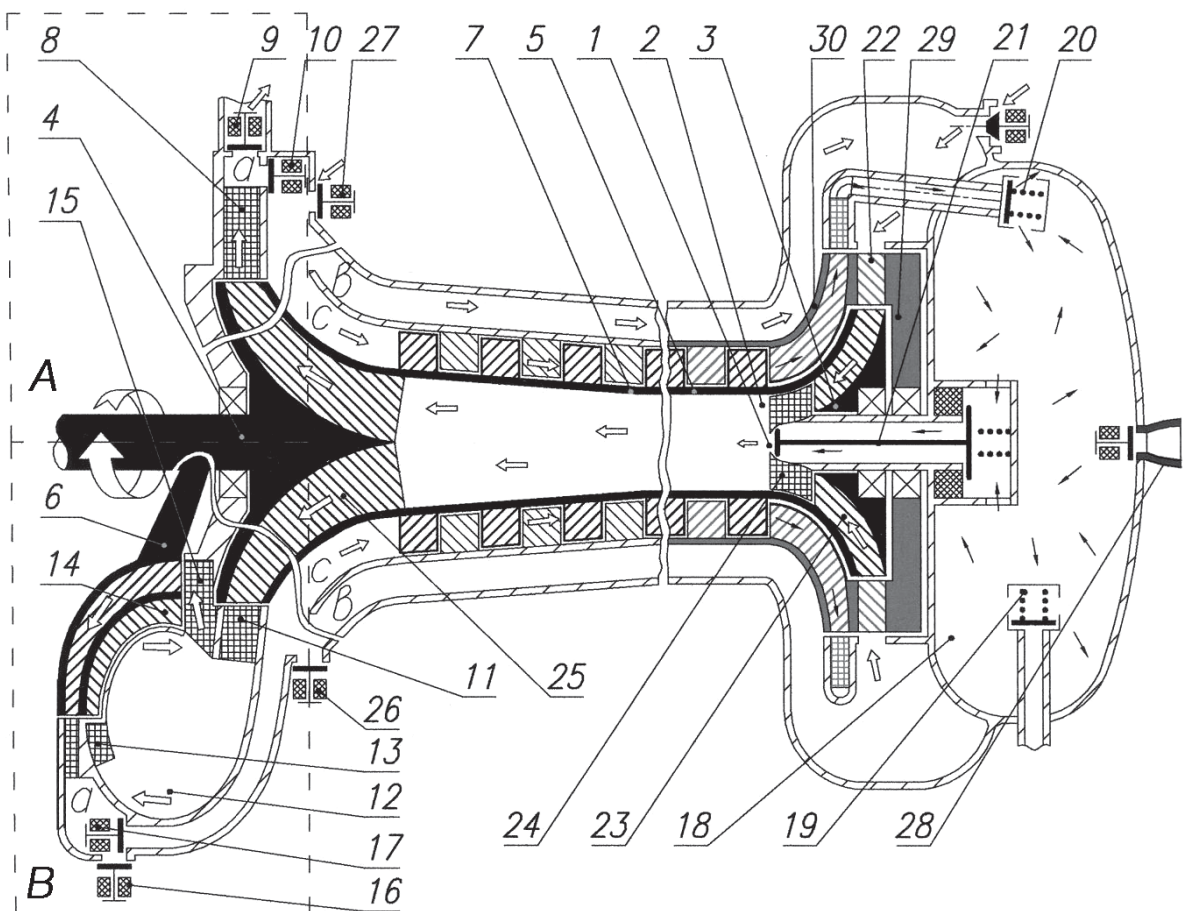

Fig. 1

following the air mass of the impulse. Under the influence of atmospheric pressure, the adjoined air accelerates following the air mass of the impulse through the valves 26, 27, blades 22 of the turbine 29, blades 23 of the turbine 3, and through the directing apparatus 24. The degree of the negative pressure obtained in the device 2, as well the time period of the pressure remaining stable, depend on the geometric parameters of the nozzle 1, device 2, their correlation and also on the thermodynamic parameters of the propulsive mass of the impulses. The degree of the negative pressure and the time period of its remaining stable influence the amount of the adjoined air, its velocity and the total head, creating momentum on the shaft 5 due to the effect of the inflowing air mass on the blades 23 of the turbine 3 and the effect of the combined reactive mass on the blades 25 of the turbine 4, mounted on the other side of the shaft. The total power obtained is used by compressor drives 6, 7 and by external consumers.

By compressing the mass processed in the compressor 7 at the expense of the E_{us} part, an increase in the effectiveness of the adjunction process can be achieved; the resulting mass can be bled to the environment at an increased pressure through the valve 9 and/or reused by feeding it through the valve 10 via the *b* and *c* channels. During this process, due to the negative pressure obtained before the compressor input 7, potential difference of the pressure increases during the formation of impulses, which, in turn, leads to an increase in the active jet's velocity. The kinetic energy of the combined reactive mass also increases, accompanied by a decrease in temperature and by an increase in the momentum on the shaft 5.

Negative pressure, used for augmenting potential difference of the pressure, may be obtained without additional energy consumption. For this purpose, jets flowing from the blades 25 of the turbine 4, are spiraled (variant B) through the directing apparatus 11. In the volume 12, to which the outflow is directed, a vortex effect is created due to the remaining kinetic energy. The negative pressure created in the central part of the effect increases potential difference of the pressure during the expansion of the working medium. At the same time, the pressure of the combined mass increases in the peripheral part of the vortex created. The combined mass acts on the blades 25 of the turbine 4 via the directing apparatus 13, and then (directly after compression in the compressor 6) is expelled through the valve 16 and/or is directed for reuse through the valve 17. In variant B, potential difference of the pres-

sure can be further augmented at the expense of using the E_{us} part by connecting the center of the volume 12 via the directing apparatus 15 to the compressor input 6.

During the compression of the resulting low-temperature mass, energy consumption on the compression work is reduced compared to compression of air at the atmospheric temperature. That is why open-cycle engines can be used not only as power generating units, but as effective generators of a high-grade working medium used by more powerful fuel-free systems. They can also be used for the creation of low-temperature propulsion jets (in nozzles 28) and for creating thrust. The effectiveness of the compression can also be increased by using birotating compressors 7 and 30 with the working wheels rotating in opposite directions.

The power density can be increased by heating the resulting low-temperature air instead, or on a par with the mechanically compressing the working medium to form the active jet. It will make possible the creation of a high-grade working medium using the heat from external sources (solar, geothermal etc.) before the expansion.

The third type. The process of consecutive adjunction can also be used to generate power, high-grade heat and "cold" outside of atmospheric conditions by transforming environmental heat energy in a closed thermodynamic cycle. Let us imagine that an atmospheric fuel-free jet engine is placed in an environmentally isolated space, filled with air or helium. During the operation of the engine, due to the cooling of the processed mass, both the temperature and pressure of the volume will decrease. The parameters of the adjunction process will change so radically that at some moment the value of E_{tm} will be insufficient to create the design power of the compressor, contracting the working medium. The degree of its contraction and C_{aj} will diminish with every following cycle. The process of adjunction will gradually fade out, and the engine, having "frozen", will stop.

It will not happen if the isolated space is used as a low-temperature heat absorber for the outflow of the processed gaseous mass, and is connected to the heat exchange device, while the output of the device is connected to the input of the adjunction device and the compressor in order to create a closed circuit. Part of the processed gaseous mass under the influence of the unbalanced force of gas pressure, appearing due to the negative pressure that forms behind the gaseous mass of the active

jet's impulses, is directed to the heat exchange device. By obtaining heat and reducing the temperature of the environment, part of the processed gaseous mass is heated up to the design temperature before performing the functions of the adjoined masses of the following periods. Under the influence of the negative pressure created on the compressor's input, part of the processed gaseous mass is directed via the heat exchange device (or bypassing it) into the compressor where it is contracted for further use.

As a result, ***by heating up the processed gaseous mass in the heat exchange device, the process of consecutive adjunction in air-independent fuel-free jet engines with a closed cycle can be performed for an unlimited period of time. It does not depend on the pressure of the environment, which acts as a heater, i.e. a source of heat transformed into work.***

The difference between fuel-free engines with a closed cycle and those with an open cycle lies in the principle of heat exchange with the environment and in the possibility of modifying the pressure and temperature in the heat exchange device. Their effectiveness to a considerable degree depends on the temperature differential between the environmental source of heat and the heat exchange device before the heating up of part of the processed gaseous mass used during the following periods. By modifying the adjunction process, the pressure and temperature of the heat-exchange device, and the degree of compression of the processed mass before reuse, the engine's power can be controlled and the range of temperatures of the environmental heat sources that are used can be expanded.

On the basis of closed-loop engines, ***air-independent autonomous fuel-free energy systems*** of a broad power range and for different applications can be created. Their operation would be possible under any environmental conditions: in outer space or under water, making possible the transformation of its low-grade heat into the three needed types of energy. If ponds, glaciers, soil and the atmosphere are used as sources of heat, the control over their aggregative state can be achieved. A local alteration of climatic conditions, depending on the scale of the fuel-free systems application, is also possible.

In conclusion, I would like to emphasize the following point: **the reactive thrust and the kinetic energy of the combined reactive mass, obtained as a result of the process of consecutive adjunction, exceed the thrust and the kinetic energy**

of the active jet. The proposed fuel-free methods of energy conversion are based on this statement, **which was verified in experiments.**

The principle of augmenting the kinetic energy is the same for all three methods: the augmentation takes place during the reestablishment of equilibrium by the gaseous masses of the low-grade working medium, which is broken by the gaseous mass of the active jet's impulses in the ejector muzzle. The adjoined masses may accelerate practically without any friction loss. Due to their acceleration, the velocity of the active jet also increases, compared to its velocity during the outflow to the constant pressure area. The amount of the increase in kinetic energy augmentation depends on the correlation of the main parameters of the process, and also on the correlation of the design parameters and the proportion of the ejector device. Turbulent mixing and friction of the gaseous masses, which drastically decrease the effectiveness of the adjunction process, are absent only in a narrow range of optimal values of parameters.

Thus, an inexhaustible and natural free energy source can be effectively transformed without any harm to the environment into three types of energy, consumed directly on the site of their generation. Such energy generation can be performed regardless of the geographical position and environment conditions and will make it possible to do away with the need for development and transportation of energy carriers, the use of long-distance transmission circuits, and the accumulation of the energy generated. The production of such systems is much easier and more effective compared to the production of analogous traditional systems, and is possible at the majority of factories that produce propulsion systems.

The proposed methods of energy transformation and the construction of turbine engines, using these principles, are intellectual property objects, protected by a Russian Federation patent. According to the Patent Cooperation Treaty (PCT), an international application has been filed. The implementation of these objects will yield great benefits to those who have signed the Treaty. Various legal forms of mutually beneficial cooperation are possible, from license agreements to joint patenting in countries of production. A version of this article, containing energy balance calculations, a schematic diagram of a fuel-free turbine engine, the description of its working principle, and additional explanations and references, can be sent by e-mail by the author on request.

Letters to the editor

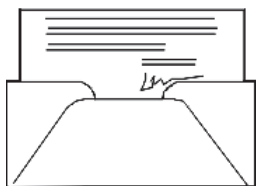

Dear Mr. Frolov,
Having studied the contents of your website www.faraday.ru, we have found the information concerning your invention to be very interesting. I would like to obtain more details on the prospects of creating a "time machine" and to offer my help should you be so kind to comply with my request. Also, if it not too much trouble, could you, please, answer the following questions?

1. What are your plans concerning practical application of the device?
2. What will be the consequences of its use?
3. Which are the main fields of application?

I am looking forward to your answer.
Best regards, K.

Thank you for your interest in the invention.

As a result of our experiments, we have found a way to change the rate of any physical processes. In this case, "time" is considered as a parameter of any process, determining its rate. The existence of any matter, including photons, is considered as a process. **The novelty lies in the fact that for the first time the rate of existence is represented by the function of aether's density.** We have also applied for a Russian Federation patent. The density of aether can be changed in many ways. During our research with Dr. Chernobrov, we tested his method of using three-layered electromagnets. Magnetostriction of the core also plays an important role. However, such a method leads to quite disputable results due to the fact that some magnetization of detectors (chronometers) takes place. I consider the creation of vortex processes in aether to be a more promising method. As

with other vortex processes, both low (the aether's temperature falls) and high (the aether's temperature rises) pressure areas can be formed in aether. The existence of matter under such "atypical conditions" looks like a change in the speed of time for this matter.

A few words about practical application of the device: a change in the rate of existence of matter **in the first place influences the activity of isotopes**; this is a method of stabilizing radioactive materials or activating of chemical transmutations of substance, accompanied by the emission of energy.

Another application is the creation of a vehicle, **moving due to the gradient of aether's density.** The application in aerospace technology is evident.

Several aspects are related to medicine, but I am not a specialist in this field. However, if the stabilization of isotopes is performed using the method in question, Ivan S. Philimonenko's ideas about immortality will be realized. He considered the process of aging to be the result of damage to the structure of cells and DNA, caused by the radiation of K-40, the main isotope, which represents the cause of the so-called "natural radiation background", and which accumulates in the human body during a lifetime. Thus, our cells are constantly repairing themselves. By eliminating such "inner irradiation", the normal functioning of body cells can be achieved, which will result in twenty-fold increase in human longevity. In addition, it is necessary to study the application of our technology for treating people who have been exposed to radiation.

I'm interested to know what your organization, and you personally, have in mind in terms of helping me to develop this particular research line?

**Alexander V. Frolov,
Faraday Lab Ltd.
7-812-3803844**

The World of Free Energy

Peter LINDEMANN

Clear Tech, Inc.

PO Box 37

Metaline Falls, WA 99153, USA

In the late 1880's, trade journals in the electrical sciences were predicting "free electricity" in the near future. Incredible discoveries about the nature of electricity were becoming commonplace. Nikola Tesla was demonstrating "wireless lighting" and other wonders associated with high frequency currents. There was an excitement about the future like never before.

Within 20 years, there would be automobiles, airplanes, movies, recorded music, telephones, radio, and practical cameras. The Victorian Age was giving way to something totally new. For the first time in history, common people were encouraged to envision a utopian future, filled with abundant modern transportation and communication, as well as jobs, housing and food for everyone. Disease would be conquered, and so would poverty. Life was getting better, and this time, everyone was going to get "a piece of the pie". So, what happened? In the midst of this technological explosion, where did the energy breakthroughs go? Was all of this excitement about "free electricity", which happened just before the beginning of the last century, all just wishful thinking that "real science" eventually disproved?

Current State of Technology

Actually, the answer to that question is NO. In fact, the opposite is true. Spectacular energy technologies were developed right along with the other breakthroughs. Since that time, multiple methods for producing vast amounts of energy at extremely low cost have been developed. None of these technologies have made it to the "open" consumer market as an article of commerce, however. Exactly why this is true will be discussed shortly. But first, I would like to describe to you a short list of "free energy" technologies that I am currently aware of, and that are proven beyond all reasonable doubt. The common feature connecting all of these discoveries, is that they use a small amount of one form of energy to control or release a large amount of a different kind of energy. Many of them tap the underlying ether field in some way; a source of energy conveniently ignored by "modern" science.

1. Radiant Energy. Nikola Tesla's Magnifying Transmitter, T. Henry Moray's Radiant Energy Device, Edwin Gray's EMA Motor, and Paul Baumann's Testatika Machine all run on Radiant Energy. This natural energy form can be gathered directly from the environment (mistakenly called "static" electricity) or extracted from ordinary electricity by the method called "fractionation." Radiant Energy can perform the same wonders as ordinary electricity, at less than 1% of the cost. It does not behave exactly like electricity, however, which has contributed to the scientific com-

munity's misunderstanding of it. The Methernitha Community in Switzerland currently has 5 or 6 working models of fuelless, self-running devices that tap this energy.

2. Permanent Magnets. Dr. Robert Adams (NZ) has developed astounding designs of electric motors, generators and heaters that run on permanent magnets. One such device draws 100 watts of electricity from the source, generates 100 watts to recharge the source, and produces over 140 BTU's of heat in two minutes! Dr. Tom Bearden (USA) has two working models of a permanent magnet powered electrical transformer. It uses a 6-watt electrical input to control the path of a magnetic field coming out of a permanent magnet. By channeling the magnetic field, first to one output coil and then a second output coil, and by doing this repeatedly and rapidly in a "Ping-Pong" fashion, the device can produce a 96-watt electrical output with no moving parts. Bearden calls his device a Motionless Electromagnetic Generator, or MEG. Jean-Louis Naudin has duplicated Bearden's device in France. The principles for this type of device were first disclosed by Frank Richardson (USA) in 1978. Troy Reed (USA) has working models of a special magnetized fan that heats up as it spins. It takes exactly the same amount of energy to spin the fan whether it is generating heat or not. Beyond these developments, multiple inventors have identified working mechanisms that produce motor torque from permanent magnets alone.

3. Mechanical Heaters. There are two classes of machines that transform a small amount of mechanical energy into a large amount of heat. The best of these purely mechanical designs are the rotating cylinder systems designed by Frenette (USA) and Perkins (USA). In these machines, one cylinder is rotated within another cylinder with about an eighth of an inch of clearance between them. The space between the cylinders is filled with a liquid such as water or oil, and it is this "working fluid" that heats up as the inner cylinder spins. Another method uses magnets mounted on a wheel to produce large eddy currents in a plate of aluminum, causing the aluminum to heat up rapidly. These magnetic heaters have been demonstrated by Muller (Canada), Adams (NZ) and Reed (USA). All of these systems can

produce ten times more heat than standard methods using the same energy input.

4. Super-Efficient Electrolysis. Water can be broken into Hydrogen and Oxygen using electricity. Standard chemistry books claim that this process requires more energy than can be recovered when the gases are recombined. This is true only under the worst case scenario. When water is hit with its own molecular resonant frequency, using a system developed by Stan Meyers (USA) and again recently by Xogen Power, Inc., it collapses into Hydrogen and Oxygen gas with very little electrical input. Also, using different electrolytes (additives that make the water conduct electricity better) changes the efficiency of the process dramatically. It is also known that certain geometric structures and surface textures work better than others do. The implication is that unlimited amounts of Hydrogen fuel can be made to drive engines (like in your car) for the cost of water. Even more amazing is the fact that a special metal alloy was patented by Freedman (USA) in 1957 that spontaneously breaks water into Hydrogen and Oxygen with no outside electrical input and without causing any chemical changes in the metal itself. This means that this special metal alloy can make Hydrogen from water for free, forever.

5. Implosion/Vortex. All major industrial engines use the release of heat to cause expansion and pressure to produce work, like in your car engine. Nature uses the opposite process of cooling to cause suction and vacuum to produce work, like in a tornado. Viktor Schaubberger (Austria) was the first to build working models of Implosion Engines in the 1930's and 1940's. Since that time, Callum Coats has published extensively on Schaubberger's work in his book *Living Energies* and subsequently, a number of researchers have built working models of Implosion Turbine Engines. These are fuelless engines that produce mechanical work from energy accessed from a vacuum. There are also much simpler designs that use vortex motions to tap a combination of gravity and centrifugal force to produce a continuous motion in fluids.

6. Cold Fusion. In March 1989, two Chemists from the University of Utah (USA) an-

nounced that they had produced atomic fusion reactions in a simple tabletop device. The claims were “debunked” within 6 months and the public lost interest. Nevertheless, Cold Fusion is very real. Not only has excess heat production been repeatedly documented, but also low energy atomic element transmutation has been catalogued, involving dozens of different reactions! This technology definitely can produce low cost energy and scores of other important industrial processes.

7. Solar Assisted Heat Pumps. The refrigerator in your kitchen is the only “free energy machine” you currently own. It’s an electrically operated heat pump. It uses one amount of energy (electricity) to move three amounts of energy (heat). This gives it a “coefficient of performance” (COP) of about 3. Your refrigerator uses one amount of electricity to pump three amounts of heat from the inside of the refrigerator to the outside of the refrigerator. This is its typical use, but it is the worst possible way to use the technology. Here’s why. A heat pump pumps heat from the “source” of heat to the “sink” or place that absorbs the heat. The “source” of heat should obviously be HOT and the “sink” for heat should obviously be COLD for this process to work the best. In your refrigerator, it’s exactly the opposite. The “source” of heat is inside the box, which is COLD, and the “sink” for heat is the room temperature air of your kitchen, which is warmer than the source. This is why the COP remains low for your kitchen refrigerator. But this is not true for all heat pumps. COP’s of 8 to 10 are easily attained with solar assisted heat pumps. In such a device, a heat pump draws heat from a solar collector and dumps the heat into a large underground absorber, which remains at 55° F, and mechanical energy is extracted in the transfer. This process is equivalent to a steam engine that extracts mechanical energy between the boiler and the condenser, except that it uses a fluid that “boils” at a much lower temperature than water. One such system that was tested in the 1970’s produced 350 hp, measured on a Dynamometer, in a specially designed engine from just 100-sq. ft. of solar collector. (This is NOT the system promoted by Dennis Lee.) The amount of energy it took to run the compressor (input) was less than 20 hp, so this

system produced more than 17 times more energy than it took to keep it going! It could power a small neighborhood from the roof of a hot tub gazebo, using exactly the same technology that keeps the food cold in your kitchen. Currently, there is an industrial scale heat pump system just north of Kona, Hawaii that generates electricity from temperature differences in ocean water.

There are dozens of other systems that I have not mentioned, many of them are as viable and well tested as the ones I have just recounted. But this short list is sufficient to make my point: free energy technology is here, now. It offers the world pollution-free, energy abundance for everyone, everywhere. It is now possible to stop the production of “greenhouse gases” and shut down all of the nuclear power plants. We can now desalinate unlimited amounts of seawater at an affordable price, and bring adequate fresh water to even the most remote habitats. Transportation costs and the production costs for just about everything can drop dramatically. Food can even be grown in heated greenhouses in the winter, anywhere. All of these wonderful benefits that can make life on this planet so much easier and better for everyone have been postponed for decades. Why? Whose purposes are served by this postponement?

The Invisible Enemy

There are four gigantic forces that have worked together to create this situation. To say that there is and has been a “conspiracy” to suppress this technology only leads to a superficial understanding of the world, and it places the blame for this completely outside of ourselves. Our willingness to remain ignorant and actionless in the face of this situation has always been interpreted by two of these forces as “implied consent.” So, besides a “non-demanding public,” what are the other three forces that are impeding the availability of free energy technology?

In standard economic theory, there are three classes of Industry. These are Capital, Goods, and Services. Within the first class, Capital, there are also three sub-classes. These are: 1) Natural Capital. This relates to raw ma-

terials (such as a gold mine) and sources of energy (such as a hydroelectric dam or an oil well). 2) Currency. This relates to the printing of paper “money” and the minting of coins. These functions are usually the job of Government. And 3) Credit. This relates to the loaning of money for interest and its extension of economic value through deposit loan accounts. From this, it is easy to see, that energy functions in the economy in the same way as gold, the printing of money by the Government, or the issuing of credit by a bank.

In the United States, and in most other countries around the world, there is a “money monopoly” in place. I am “free” to earn as much “money” as I want, but I will only be paid in Federal Reserve Notes. There is nothing I can do to be paid in Gold Certificates, or some other form of “money.” This money monopoly is solely in the hands of a small number of private stock banks, and these banks are owned by the Wealthiest Families in the world. Their plan is to eventually control 100% of all of the Capital resources of the world, and thereby control everyone’s life through the availability (or non-availability) of all goods and services. An independent source of wealth (free energy device) in the hands of each and every person in the world, ruins their plans for world domination, permanently. Why this is true is easy to see. Currently, a nation’s economy can be either slowed down or sped up by the raising or lowering of interest rates. But if an independent source of capital (energy) were present in the economy, and any business or person could raise more capital without borrowing it from a bank, this centralized throttling action on interest rates would simply not have the same effect. Free energy technology changes the value of money. The Wealthiest Families and the Issuers of Credit do not want any competition. It’s that simple. They want to maintain their current monopoly control of the money supply. **For them, free energy technology is not just something to suppress, it must be PERMANENTLY FORBIDDEN!**

So, the Wealthiest Families and their Central Banking institutions are the First Force operating to postpone the public availability of free energy technology. **Their motiva-**

tions are the imagined “divine right to rule”, greed, and their insatiable need to control everything except themselves. The weapons they have used to enforce this postponement include intimidation, “expert” debunkers, buying and shelving of technology, murder and attempted murder of the inventors, character assassination, arson, and a wide variety of financial incentives and disincentives to manipulate possible supporters. They have also promoted the general acceptance of a scientific theory that states that free energy is impossible (Laws of Thermodynamics).

The Second Force operating to postpone the public availability of free energy technology is National Governments. The problem here is not so much related to competition in the printing of currency, but in the maintenance of National Security. The fact is, the world out there is a jungle, and humans can be counted upon to be very cruel, dishonest, and sneaky. It is Government’s job to “provide for the common defense.” For this, “police powers” are delegated by the Executive Branch of Government to enforce “the rule of law.” Most of us who consent to the rule of law do so because we believe it is the right thing to do, for our own benefit. There are always a few individuals, however, that believe that their own benefit is best served by behavior that does not voluntarily conform to the generally agreed upon social order. These people choose to operate outside of “the rule of law” and are considered outlaws, criminals, subversives, traitors, revolutionaries, or terrorists.

Most National Governments have discovered, by trial and error, that the only Foreign Policy that really works, over time, is a policy called “Tit for Tat.” What this means to you and me is, that governments treat each other the way they are being treated. There is a constant “jockeying” for position and influence in world affairs, and the STRONGEST party wins! In economics, it’s the Golden Rule, which states: “The one with the Gold makes the Rules.” So it is with politics also, but its appearance is more Darwinian. It’s simply “survival of the fittest.” In politics, however, the “fittest” has come to mean the strongest party who is also willing to fight the dirtiest. Absolutely every means

available is used to maintain an advantage over the “adversary”, and everyone else is the “adversary” regardless of whether they are considered friend or foe. This includes outrageous psychological posturing, lying, cheating, spying, stealing, assassination of world leaders, proxy wars, alliances and shifting alliances, treaties, foreign aid, and the presence of military forces wherever possible. Like it or not, this IS the psychological and actual arena National Governments operate in. No National Government will ever do anything that simply gives an adversary an advantage for free. NEVER! It’s national suicide. Any activity by any individual, inside or outside the country, that is interpreted as giving an adversary an edge or advantage, in any way, will be deemed a threat to “National Security.” ALWAYS!

Free energy technology is a National Government’s worst nightmare! Openly acknowledged, free energy technology sparks an unlimited arms race by all governments in a final attempt to gain absolute advantage and domination. Think about it. Do you think Japan will not feel intimidated if China gets free energy? Do you think Israel will sit by quietly as Iraq acquires free energy? Do you think India will allow Pakistan to develop free energy? Do you think the USA would not try to stop Osama bin Laden from getting free energy? Unlimited energy available to the current state of affairs on this planet leads to an inevitable reshuffling of the “balance of power.” This could become an all-out war to prevent “the other” from having the advantage of unlimited wealth and power. Everybody will want it, and at the same time, want to prevent everyone else from getting it.

So, National Governments are the Second Force operating to postpone the public availability of free energy technology. Their motivations are “self-preservation.” This self-preservation operates on three levels. First, by not giving undue advantage to an external enemy. Second, by preventing individualized action capable of effectively challenging official police powers (anarchy) within the country. And third, by preserving income streams derived from taxing energy sources currently in use. Their weapons include the preventing of the issuance of patents based

on National Security grounds, the legal and illegal harassment of inventors with criminal charges, tax audits, threats, phone taps, arrest, arson, theft of property during shipment, and a host of other intimidations which make the business of building and marketing a free energy machine impossible.

The Third Force operating to postpone the public availability of free energy technology consists of the group of deluded inventors and out right charlatans and con men. On the periphery of the extraordinary scientific breakthroughs that constitute the real free energy technologies, lies a shadow world of unexplained anomalies, marginal inventions and unscrupulous promoters. The first two Forces have constantly used the media to promote the worst examples of this group, to distract the public’s attention and to discredit the real breakthroughs by associating them with the obvious frauds.

Over the last hundred years, dozens of stories have surfaced about unusual inventions. Some of these ideas have so captivated the public’s imagination that a mythology about these systems continues to this day. Names like Keely, Hubbard, Coler, and Henderschott immediately come to mind. There may be real technologies behind these names, but there simply isn’t enough technical data available in the public domain to make a determination. These names remain associated with a free energy mythology, however, and are cited by debunkers as examples of fraud.

The idea of free energy taps very deeply into the human subconscious mind. A few inventors with marginal technologies that demonstrate useful anomalies have mistakenly exaggerated the importance of their inventions. Some of these inventors also have mistakenly exaggerated the importance of THEMSELVES for having invented it. A combination of “gold fever” and/or a “messiah complex” appears, wholly distorting any future contribution they may make. While the research thread they are following may hold great promise, they begin to trade enthusiasm for facts, and the value of the scientific work from that point on suffers greatly. There is a powerful, yet subtle seduction that can warp a personality if they believe that “the world rests on their shoulders” or that

they are the world's "savior." Strange things also happen to people when they think they are about to become extremely rich. It takes a tremendous spiritual discipline to remain objective and humble in the presence of a working free energy machine. Many inventors' psyches become unstable just BELIEVING they have a free energy machine. As the quality of the science deteriorates, some inventors also develop a "persecution complex" that makes them very defensive and unapproachable. This process precludes them from ever really developing a free energy machine, and fuels the fraud mythologies tremendously.

Then there are the out right con men. In the last 15 years, there is one person in the USA who has raised the free energy con to a professional art. He has raised more than \$100,000,000, has been barred from doing business in the State of Washington, has been jailed in California, and he's still at it. He always talks about a variation of one of the real free energy systems, sells people on the idea that they will get one of these systems soon, but ultimately sells them only promotional information which gives no real data about the energy system itself. He has mercilessly preyed upon the Christian Community and the Patriot Community in the USA, and is still going strong. His current scam involves signing up hundreds of thousands of people as locations where he will install a free energy machine. In exchange for letting him put the FE generator in their home, they will get free electricity for life, and his company will sell the excess energy back to the local utility company. After becoming convinced that they will receive free electricity for life, with no out-front expenses, they gladly buy a video that helps draw their friends into the scam as well. Once you understand the power and motivations of the first two Forces I have discussed, its obvious that this person's current "business plan" cannot be implemented. This one person has probably done more harm to the free energy movement in the USA than any other Force, by destroying people's trust in the technology.

So, the Third Force postponing the public availability of free energy technology is delusion and dishonesty within the movement itself. The motivations are self-aggrandize-

ment, greed, want of power over others, and a false sense of self-importance. The weapons used are lying, cheating, the "bait and switch" con, self-delusion and arrogance combined with lousy science.

The Fourth Force operating to postpone the public availability of free energy technology is all of the rest of us. It may be easy to see how narrow and despicable the motivations of the other Forces are, but actually, these motivations are still very much alive in each of us as well. Like the Wealthiest Families, don't we each secretly harbor illusions of false superiority, and the want to control others instead of ourselves? Also, wouldn't you "sell out" if the price were high enough, say, take \$1 million dollars, cash, today? Or like the Governments, don't we each want to ensure our own survival? If caught in the middle of a full, burning theater, do you panic and push all of the weaker people out of the way in a mad, scramble for the door? Or like the deluded inventor, don't we trade a comfortable illusion once in a while for an uncomfortable fact? And don't we like to think more of ourselves than others give us credit for? Or don't we still fear the unknown, even if it promises a great reward?

You see, really, all Four Forces are just different aspects of the same process, operating at different levels in the society. There is really only ONE FORCE preventing the public availability of free energy technology, and that is the unspiritually motivated behavior of the human animals. In the last analysis, free energy technology is an outward manifestation of Divine Abundance. It is the engine of the economy of an enlightened society, where people voluntarily behave in a respectful and civil manner toward each other. Where each member of the society has everything they need, and do not covet what their neighbor has. Where war and physical violence has become socially unacceptable behavior and people's differences are at least tolerated, if not enjoyed.

The appearance of free energy technology in the public domain is the dawning of a truly civilized age. It is an epochal event in human history. Nobody can "take credit" for it. Nobody can "get rich" on it. Nobody can "rule the world" with it. It is simply, a Gift from

God. It forces us all to take responsibility for our own actions and for our own self-disciplined self-restraint when needed. The world as it is currently ordered, cannot have free energy technology without being totally transformed by it into something else. **This “civilization” has reached the pinnacle of its development, because it has birthed the seeds of its own transformation. The unspiritualized human animals cannot be trusted with free energy. They will only do what they have always done, which is take merciless advantage of each other, or kill each other and themselves in the process.**

If you go back and read *Ayn Rand’s Atlas Shrugged* or the *Club of Rome Report*, it becomes obvious that **the Wealthiest Families have understood this for decades**. Their plan is to live in The World of Free Energy, but permanently freeze the rest of us out. But this is not new. Royalty has always considered the general population (us) to be their subjects. What is new, is that you and I can communicate with each other now better than at anytime in the past. The Internet offers us, the Fourth Force, an opportunity to overcome the combined efforts of the other Forces preventing free energy technology from spreading.

The Opportunity

What is starting to happen is that inventors are publishing their work, instead of patenting it and keeping it secret. More and more, people are “giving away” information on these technologies in books, videos and websites. While there is still a great deal of useless information about free energy on the Internet, the availability of good information is rising rapidly. Check out the list of websites and other resources at the end of this article.

It is imperative that you begin to gather all of the information you can on real free energy systems. The reason for this is simple. The first two Forces will never allow an inventor or a company to build and sell a free energy machine to you! The only way you will ever get one is if you, or a friend, **build it yourself**. This is exactly what thousands of people are already quietly starting to do. You

may feel wholly inadequate to the task, but start gathering information now. You may be just a link in the chain of events for the benefit of others. Focus on what you can do now, not on how much there still is to be done. Small, private research groups are working out the details as you read this. Many are committed to publishing their results on the Internet.

All of us constitute the Fourth Force. If we stand up and refuse to remain ignorant and action-less, we can change the course of history. It is the aggregate of our combined action that can make a difference. Only the mass action that represents our consensus can create the world we want. The other three Forces WILL NOT help us put a fuel-less power plant in our basements. They will not help us be free from their manipulations. **Nevertheless, free energy technology is here. It is real, and it will change everything about the way we live, work and relate to each other. In the last analysis, free energy technology obsoletes greed and the fear for survival. But like all exercises of Spiritual Faith, we must first manifest the generosity and trust in our own lives.**

The Source of Free Energy is INSIDE of us. It is that excitement of expressing ourselves freely. It is our Spiritually guided intuition expressing itself without distraction, intimidation or manipulation. It is our open-heartedness. Ideally, the free energy technologies underpin a just society where everyone has enough food, clothing, shelter, self-worth, and the leisure time to contemplate the higher Spiritual meanings of Life. Do we not owe it to each other, to face down our fears, and take action to create this future for our children’s children? Perhaps I am not the only one waiting for me to act on a greater Truth.

Free energy technology is here. It has been here for decades. Communications technology and the Internet have torn the veil of secrecy off of this remarkable fact. People all over the world are starting to build free energy devices for their own use. The Bankers and the Governments do not want this to happen, but cannot stop it. Tremendous economic instabilities and wars will be used in the near future to distract people from joining the free energy movement. There will be

essentially no major media coverage of this aspect of what is going on. It will simply be reported as wars and civil wars erupting everywhere, leading to UN "Peace Keeper" occupation in more and more countries.

Western Society is spiraling down toward self-destruction, due to the accumulated effects of long-term greed and corruption. The general availability of free energy technology cannot stop this trend. It can only reinforce it. If, however, you have a free energy device, you may be better positioned to sur-

vive the political/social/economic transition that is underway. No National Government will survive this process. The question is, who will ultimately control the emerging World Government, the First Force, or the Fourth Force?

The last Great War is almost upon us. The seeds are planted. After this will come the beginning of a real Civilization. Some of us who refuse to fight will survive to see the dawn of the World of Free Energy. I challenge you to be among the ones who try.

LIST OF RESOURCES:

BOOKS:

Living Energies by Callum Coats
The Free Energy Secrets of Cold Electricity by Peter Lindemann, D.Sc.
Applied Modern 20th Century Aether Science by Dr. Robert Adams
Physics Without Einstein by Dr. Harold Aspden
Secrets of Cold War Technology by Gerry Vassilatos
The Coming Energy Revolution by Jeane Manning

WEBSITES:

<http://www.fortunecity.com/greenfield/bp/16/content1.htm> excellent free-energy site run by Geoff Egel based in Australia
<http://www.free-energy.cc/> developed by Clear Tech, Inc. and Dr. Peter Lindemann
<http://jnaudin.free.fr/> developed by JLN Labs in France
<http://www.1dove.com/fe/index.html> Jim's Free Energy Page in the USA
<http://www.keelynet.com/> developed by Jerry Decker in the USA
<http://www.xogen.com> site for super electrolysis technology
<http://www.rumormillnews.com> excellent site for all kinds of alternative news, with many links
For more links to other recommended sites, see the "Links Page" at <http://www.free-energy.cc>

PATENTS: (most can be viewed at www.delphion.com/) This list is nothing more than a sample of inventions that produce free energy.

Tesla USP #685,957
Freedman USP #2,796,345
Richardson USP #4,077,001
Frenette USP #4,143,639
Perkins USP #4,424,797
Gray USP #4,595,975
Meyer USP #4,936,961
Chambers USP #6,126,794

LUTEC Magnet Generator

Editor: the article dedicated to the work of the LUTEC Company aroused our readers' interest (the web-site of the LUTEC Company is <http://www.lutec.com/au>). This article contains the latest news from the developers of this new technology.

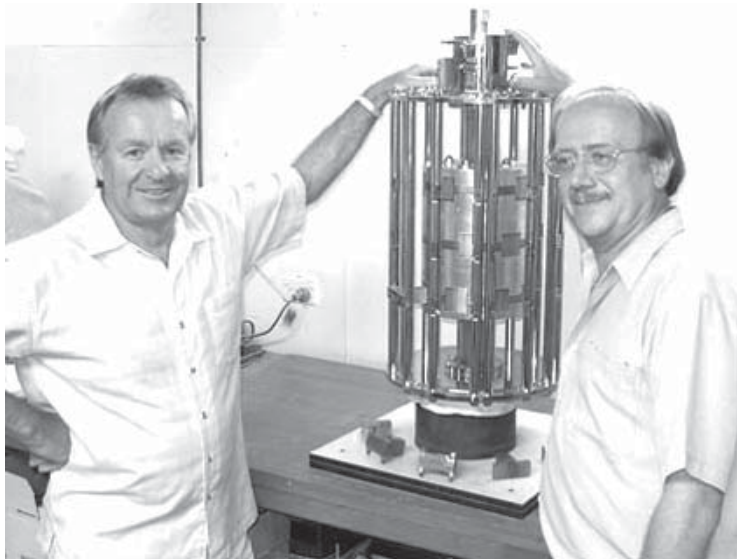

Fig. 1

The Lutec 1000 is the first free energy machine to be developed to commercial stage anywhere in the world. The Lutec 1000 generator will produce up to 1000 watts of DC electricity twenty four hours a day, every day, which will be stored in a battery bank and then inverted to AC power and connected directly into the home or business.

The Lutec 1000 draws the power it requires to run itself from the same battery bank. The average house in Cairns, Queensland, uses only fourteen of the twenty four kilowatt hours able to be stored in twenty four hours by this method. The batteries will last ten years. The generator is expected to come with a conditional ten-year warranty.

The magnets that are responsible for the generation have an effective life

of one thousand three hundred years. This product is non-polluting. It will assist to bring down green house gases and therefore help cure our sick and dying planet. There are strong community health benefits. It will help slow the rate of use of non-renewable resources, like oil. It will help reduce airborne emissions of gases and elements that ruin our forests and lakes.

National Phase Patent Applications filed in the name of Ludwig Emma Brits and Victor John Christie from PCT/AU99/00962 claiming priority from Australian Provisional Patent Application No. PP6961 filed 6 November 1998

How it Works

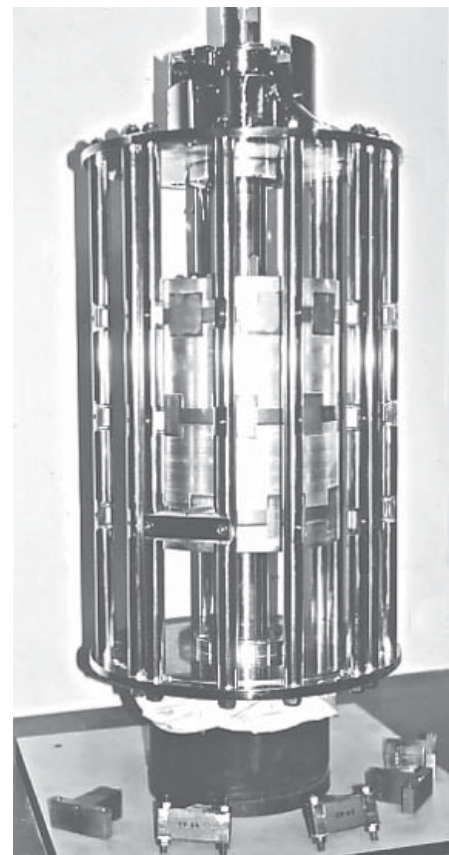

Fig. 2

The authors write: “We have never said there is an “endless” source of energy emanating from magnets. We have said that the magnets we use in the Lutec 1000 are able to maintain their magnetic qualities for over twelve hundred years. That is a long time when gauged by human life expectancy, but is not forever. We welcome informed opinion, and to that end have sought out the highest qualified people in Australia and the United States of America to review our work.

The Lutec 1000 only baffles those who misinterpret the actions taking place within it as being outside common scientific principles and laws, where in fact it certainly is not. We will try to make a simple explanation to demonstrate what motivates the Lutec 1000 motor/generator:

Let’s say we hang a ten kilo weight off a permanent magnet butted to a steel roofing beam, and that the only thing holding the permanent magnet to the steel beam is the magnetism. Now let’s do the same thing, but this time with an electromagnet which requires a constant electrical input to maintain its magnetic qualities.

Let’s say we leave them both there for ten years...

They will both perform the same task, that of holding the ten kilos off the floor. The electromagnet, however, has needed to be fuelled by electricity provided by a generator of some kind – it could be hydro, nuclear, wind, solar, coal or oil – and has cost a large amount in terms of energy. Much work (in the scientific sense) has been done to provide the constant electric current necessary to maintain its magnetic hold on the steel girder.

Now take notice, the permanent magnet has not needed to be energised by an external source, it has done the job for “free” using only the magnetism it contains to perform the same job. The clue here is in the title of “permanent” magnet.

That same principle is one of the reasons the Lutec 1000 motor turns, it is of course the spinning of the centre core of the motor which is caused by the permanent magnets being attracted and then repulsed from the steel cores of the fixed stator coils. It is this primary movement that allows the magnetic fields around the stator coils to be “cut” by the effect of the permanent magnets sweeping past the steel cores of the coils.



Fig. 3

Note that we have achieved two effects from one cause, thus inducing an electric current per Mr Faraday’s theory, and so generating electricity as an output or product of the motors motion. The only electricity consumed has been that required to temporarily charge the coils and so creating a temporary magnet of like polarity to cause the permanent magnet to be repulsed rather than attracted.

There are a couple of other major factors that we won’t go into here, suffice it to say that our current prototype demonstrates 1500% more “out” than “in” (15:1).

Progress

Time has become the essence in respect of announcements regarding the possible marketing of a product designed around the technology. There are “commercial in confidence” dealings going on behind the scenes that require of us to provide certain patents for specific areas. These patents must be granted to enable the parties involved to raise the capital needed to finance the huge undertaking of introducing the technology to the world. This patent issue alone caused significant slowing of the program because of the amount of time it has taken for the specific countries to provide the full patent protection. That milestone has now been achieved.

What now remains is for the proof of concept prototype currently in work to be completed to the satisfaction of the aforesaid parties. People are chatting on the net and no doubt in other places surmising what technical difficulties may be causing problems. In particular those relating to the switching of the input electricity that allows the coil cores to become energised as temporary magnets, and how to handle the subsequent back EMF spikes caused by the collapsing field. We have got it figured out and are hard

at work fine-tuning the new system designed specifically for the task. Previously we were concentrating on a solid-state system, no moving parts, and we had the luxury of time to experiment with that notion while waiting for the patents to come through. Now however it is more important to have the system running at a certain level, so we have reverted to the old method. Once perfected it will not be difficult to produce a solid-state system as the data of what is required and the entire associated variables will be identified mapped and analysed by computer for the purpose. This can't be done with the existing switching system.

The bottom line is we are not prepared at this time to make a guess at when product will or might be available. It can be fairly safely assumed that final design, construction, testing and satisfying regulatory authorities could take

one to two years. It's a case of wait and see, everything hinges on our completing the prototype to the degree required, after which things will move very quickly.

Hopefully the next update will be before Christmas 2003 and not need to be as long winded as this. Thank you for reading this far. We are trying to reply to emails but the numbers are so high it is very difficult. Please bear with us, don't stop writing; the encouragement and support we get from you is fantastic and very welcome, but please don't be dismayed should you not receive a personal reply for a long time".

A more detailed information could be found on the company's web-site <http://www.lutec.com/au>

Pulsed Direct Current for Light Circuits

Engineering report
Gary MAGRATTEN
26901 Ridge Rd.
Willits CA 95490, USA
tel: 707-459-1435
fax: 707-459-9298

Theory in brief:

The Gray Circuit can be employed to power a light circuit or a pulse DC motor more efficiently. There are five main principles that make the Gray Circuit uniquely efficient. Understanding these principles can be of great importance to increasing the efficiency of a circuit when designing for light circuits and pulsed DC motors.

***Editor:** A short variant of this article was published in the previous issue. A full variant, which we have recently received is given below. We would like to stress once again that it was P.N. Yablochkov, a Russian inventor, who way back in 1877 described a method of current amplification by means of introducing an electric spark to a circuit (Patent № 120684, 11.10.1877).*

- 1) There is a substantial current gain developed by an electric spark in open air. Gray employed a spark gap in the design of his motor and power supply. This will be explained in the summary of the text, **'The Mechanism of the Electric Spark'** by L. Loeb and J. Meek.
- 2) A load circuit can be electrostatically coupled to the primary circuit by employing

the '**Inverse Photoelectric Effect**'. This will be explained by a brief summary of the principle of 'inverse photoelectric effect'.

- 3) **Pulsed DC** can provide a more efficient means of delivering power to a light circuit or a pulsed DC motor by providing power for a short duration at the optimum time.
- 4) **Back EMF** or counter EMF from the collapsing magnetic field of an inductive coil can be utilized to do work that otherwise would be wasted.
- 5) **Energy Recycling**. Current from the primary circuit is recycled back to the negative terminal of the primary battery for reuse. Current from the primary circuit is also cycled back to recharge a secondary battery.

The Mechanism of Positive Streamer Formation

The photoelectrons created at points in the gas and at the cathode at any great radial distance from the avalanche axis will merely create other avalanches.

Those in the gas will be short and those coming from the cathode region will be long and like that of the initial avalanche. Being smaller and, in any case, later in creation than the pattern avalanche, such avalanches will be of no interest in breakdown. However, those photoelectrons created near the space-charge channel of positive ions, and especially near the anode, will be in an enhanced field which exerts a directive action drawing them into itself. If the space-charge field [X1] is in the order of magnitude of the imposed field [X], this action will be very effective. In addition the values of [a] will be much enhanced.

The electrons from the intense cumulative ionization of such photoelectron avalanches in the combined fields [X] and [X1] which are drawn into the positive space charge feed into it, making it a conducting PLASMA which starts at the anode. The added fields will be most effective along [X] and so will the ionization. The positive ions they leave behind will therefore extend the space charge towards the cathode. These electrons

also create photons which produce electrons to continue this process. **In this fashion the positive space charge develops toward the cathode from the anode as a self-propagating positive space-charge streamer.**

As the streamer advances towards the cathode it produces a filamentary region of intense space-charge distortion along a line parallel to the field. The conducting streamer of a plasma consisting of electrons and ions extending to the anode **thus makes a very steep gradient at the cathode end of the streamer tip.** As this advances toward the cathode the photoelectron avalanches produced by radiation at the cathode, especially at the intercept of the extended streamer axis at the cathode, it begins to produce an intense ionization near the cathode. Hence the positive ions created there may increase the secondary emission. Thus, as the space-charge streamer approaches the cathode a cathode spot is forming which may become a source of visible light. When the streamer reaches the cathode there is a conducting filament bridging the gap. As the streamer tip reaches the cathode the high field produces a rush of electrons towards the end of the streamer. This is followed by a current of electrons, gives a high-potential wave which passes up the preionized conducting channel to the anode, **multiplying the electrons present by a large factor.** The channel is thus rendered highly conducting. If the metal can emit a copious supply of electrons because of the formation of an efficient cathode spot, the current of electrons continues the channel maintaining its high conductivity and **ever increasing in it.** This current, unless limited by external resistance, will then develop into an **arc.** It is, however, the intense increase of ionization by the potential wave which gives the highly conducting channel characterizing the spark.

Conclusion: According to Loeb and Meek, there are three means by which a spark in open air will provide a very large current gain. If this is true, it should be fairly easy to prove with inexpensive and unsophisticated equipment. Once the actual amount of current gain has been determined for the design parameters of the spark gap, then the rest of the circuit can be designed for the increased current value.

Next: The Quantitative Criterion For Streamer Formation

The Mechanism of the Electric Spark

The electron multiplication of electrons by the cumulative ionization of a single electron liberated from the cathode by a photon.

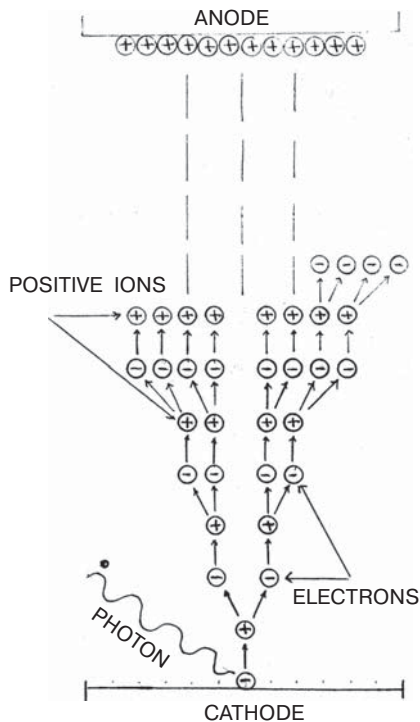

Fig. 1

The Mechanism of the Electric Spark

The development and structure of an avalanche, with positive ions behind the electrons at the tip. The avalanche has crossed the gap, spreading by diffusion.

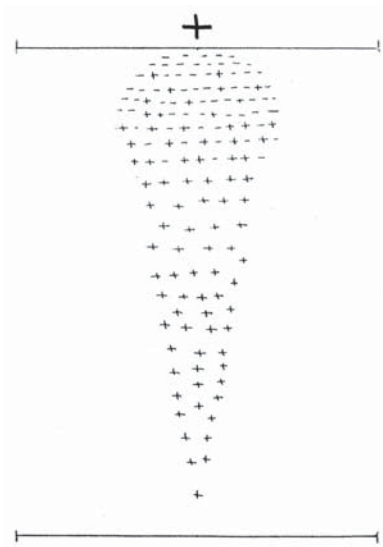

Fig. 2

The Mechanism of the Electric Spark

The later history of an avalanche. Electrons have disappeared into the anode. Positive space-charge boss appears on the anode. Ion pairs out from the trail indicate the appearance of photoelectric ion pairs in the gas produced by photons from the avalanche.

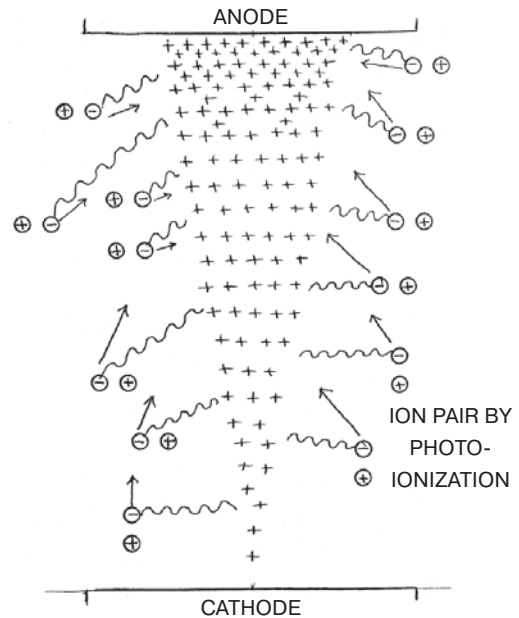

Fig. 3

Efficient Power Supply Suitable For Inductive Loads Patent Number: 4,595,975

Summary of the Invention

The present invention provides a more efficient driving system comprising a source of electrical voltage; a vibrator connected to the low-voltage source for forming a pulsating signal; a transformer connected to the vibrator for receiving the signal; a high-voltage source, where available, connected to a bridge-type rectifier; or the bridge type rectifier connected to the high voltage pulse output of the transformer; a capacitor for receiving the voltage pulse output; a conversion element having first and second anodes, electrically conductive means for receiving a charge positioned around the second anode and an output terminal connected to the ca-

pacitor; a commutator connected to the source of the electrical voltage and to the first anode; and an inductive load connected to the output terminal whereby a high energy discharge between the first and the second anodes is transferred to the charge receiving means and then to the inductive load.

Edwin Vincent Gray (1925 – 1989)

Edwin Gray was born in Washington, DC in 1925. He was one of 14 children. At age eleven, he became interested in emerging field of electronics, when he watched some of the first demonstrations of primitive radar being tested across the Potomac River. He left home at 15 and joined the Army, attended advanced engineering school for one year before he was discovered and honorably discharged for being under age. After the attack of Pearl Harbor, he re-enlisted in the Navy and served three years of combat duty in the Pacific.

After the war, he worked as a mechanic and continued his studies in electro-magnetics. After experimenting for years, he learned how to “split the positive” in 1958 and had his first Electric Magnetic Association (EMA) motor model running in 1961. His third EMA prototype was successfully tested for 32 days straight before it was torn down for analysis. With this report in hand, Gray started looking for serious funding. After being turned down by every major corporation and venture capital group he approached, he formed his own Limited partnership in 1971. By early 1973, EVGray Enterprises, Inc. had an office in Van Nuys, California, hundreds of private investors and a new (#4) EMA motor prototype. Ed Gray had also received a “Certificate of Merit” from Ronald Reagan, then Governor of California.

By the summer of 1973, Gray was doing demonstrations of his technology and receiving some very positive press. By later this year, Gray had teamed up with automobile designer Paul M. Lewis, to build the first fuelless, electric car in America. But trouble was brewing.

On July 22, 1974, an unprovoked Los Angeles District Attorney’s Office raided the office and shop of EVGray Enterprises, and confiscated all of their business records and working prototypes. For 8 months, the DA tried to get Gray’s stockholders to file charges against him, but none would. Gray was eventually charged with “grand theft”, but even this bogus charge couldn’t stick and was finally dropped. By March 1976, Gray pleaded guilty to two minor SEC violations, was fined, and released. The DA’s office never returned his prototypes.

In spite of these troubles, a number of good things were happening. His first U.S. Patent,

U.S. Patent Jun. 17, 1986 Sheet 1 of 2 **4,595,975**

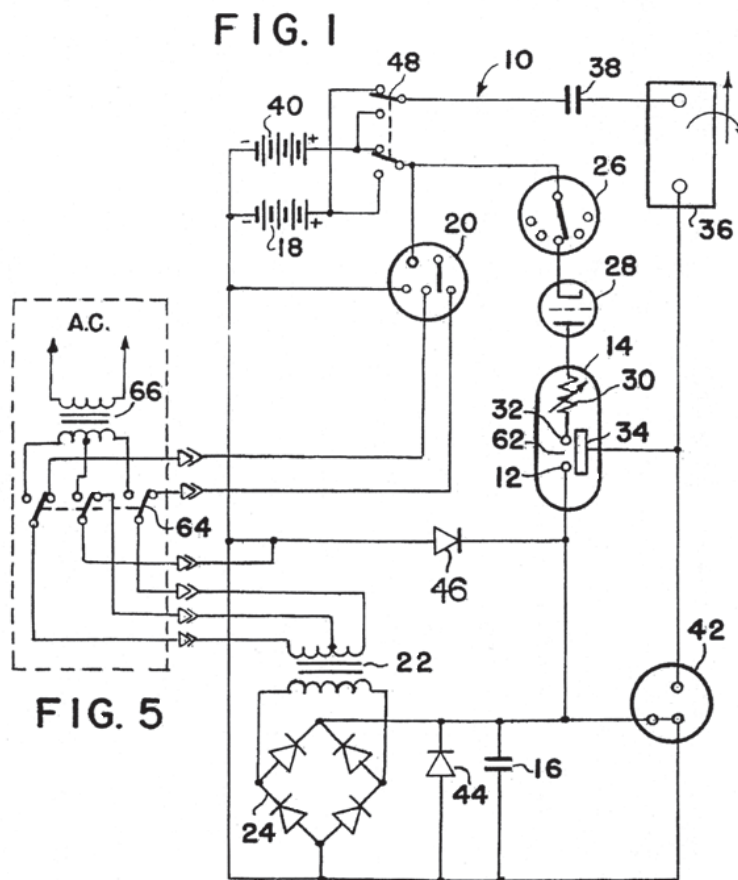

Fig. 4

on the motor design, issued in June of 1975, and by February 1976, Gray was nominated for "Inventor of the Year" for "discovering and proving a new form of electric power" by Los Angeles Patent Attorney's Association. Despite this support, Gray kept a much lower profile after this time. In the late 1970's, Zetech, Inc. acquired Gray's technology and EVGray Enterprises ceased to exist. In the early 1980's, Gray offered the U.S. Government his technology to augment Reagan's SDI program. He actually wrote letters to every member of Congress, both Senators and Representatives, as well as the President, Vice President, and every member of the Cabinet. Remarkably, in response to this letter writing campaign, Gray did not

receive a single reply or even an acknowledgement!

During the early 1980's, Gray lived in Council, Idaho, where he wrote and was granted his other two U.S. Patents. By 1986, he had a facility in Grande Prairie, Texas, where a number of new prototype EMA motors were built. By 1989, he was working on propulsion applications of the technology, and maintaining his residence in Council, Idaho, as well as shop facilities in Council, Grande Prairie, and Sparks, Nevada.

Edwin V. Gray died at his shop in Sparks, Nevada, in April, 1989, under mysterious circumstances. He was 64 and in good health.

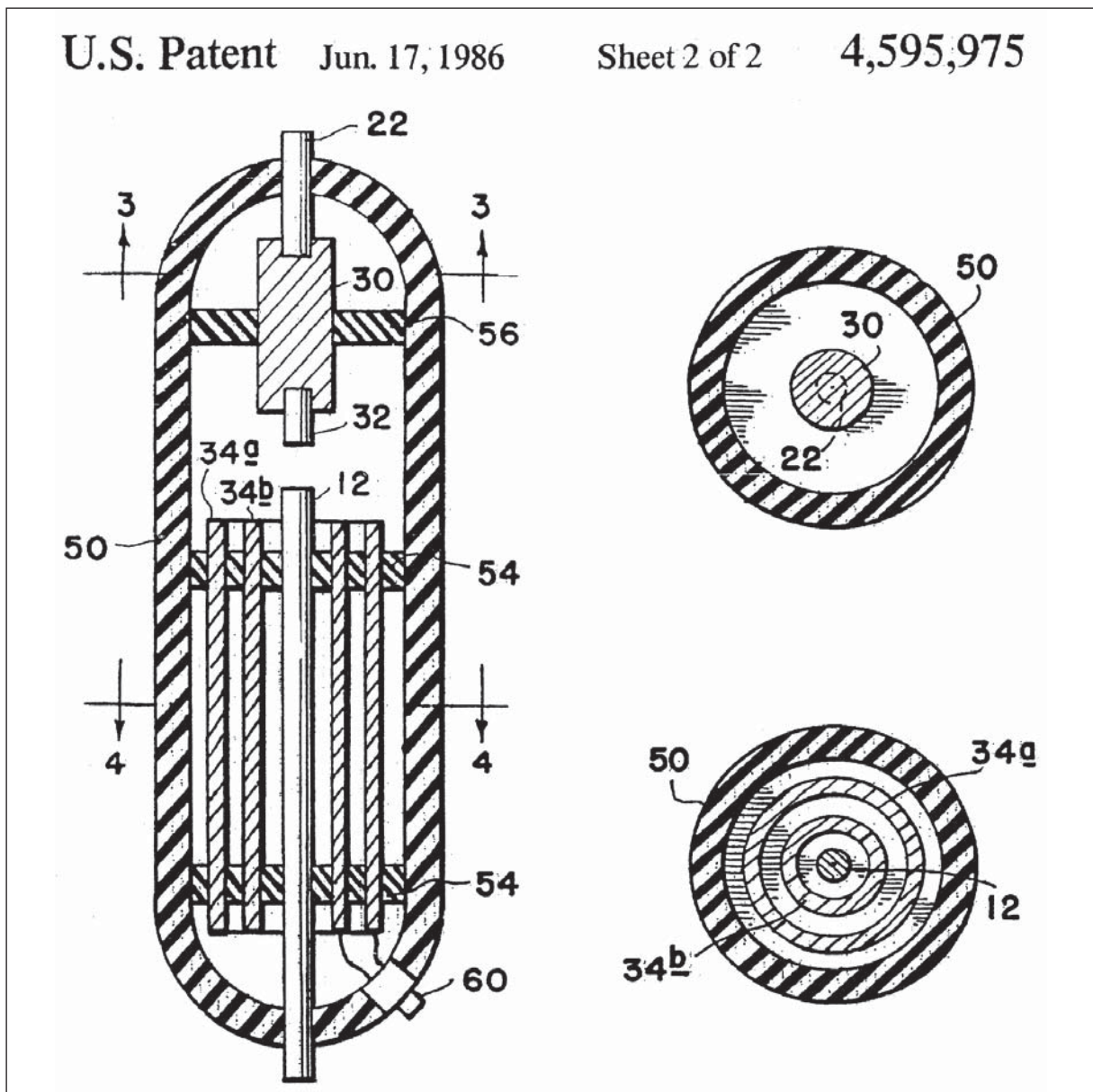

Fig. 5

Patent Applications on Thermo-gravitation

Application registration number **96104919/06**
 Date of filing **1996.03.18**
 Title **A Two-phase Gravity Drive**
 Inventors **E.V. Soloviev**
V.V. Privezentsev
 Patent holder **Russian Federation State Scientific Centre, the Institute of Physics and Energy**

Summary

Application: the transformation of the energy of low-grade heat sources into mechanical energy. The essence of the invention: a vertically positioned tube is situated under the turbine inside the case of a thermosyphon with a gap relative to the case of the thermosyphon and the rotor of the turbine. A minimum one liquid-vapor turbine nozzle is situated in the clearance between the side face of the tube and the case. The construction of the turbine is liquid-vapor, while the level of boiling water exceeds the level of the turbine.

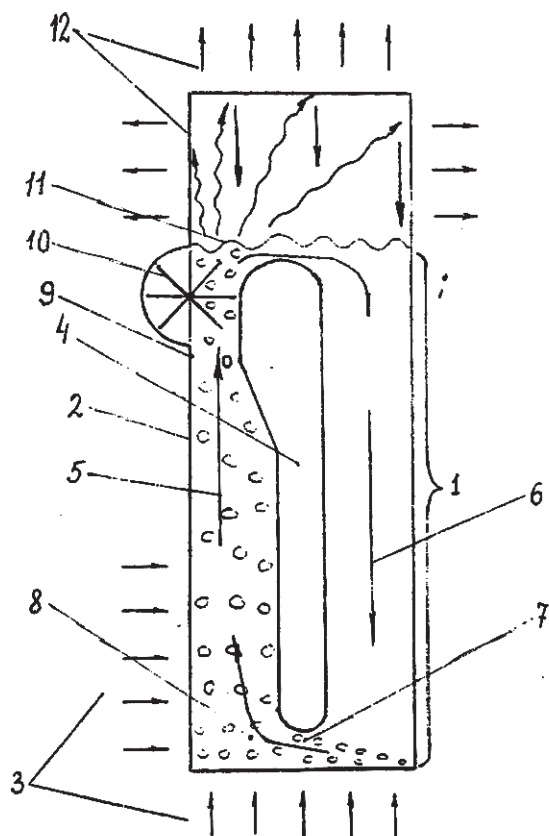

Fig. 1

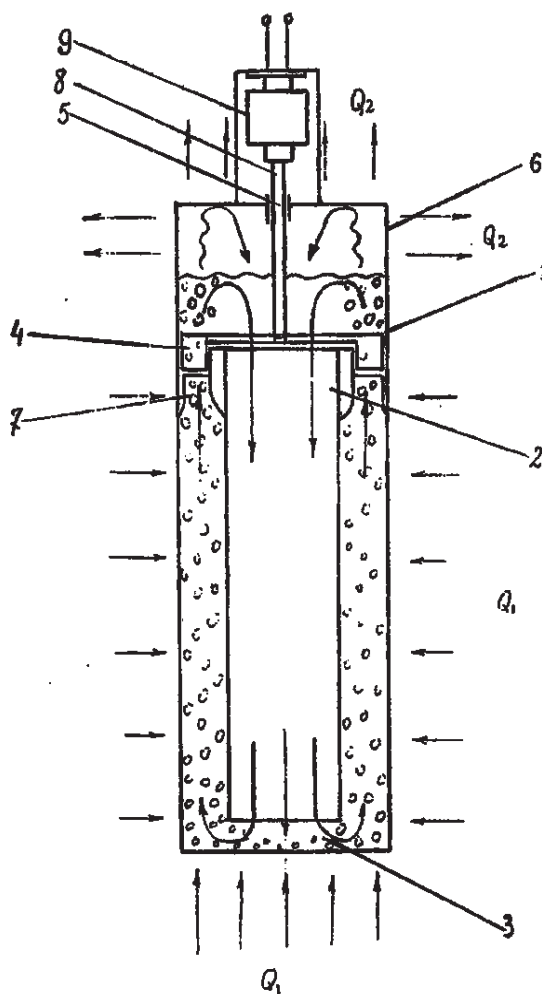

Fig. 2

An Electrogravitational Engine

Patent Application N 97116748/09
Inventors: **V.V. FEDOROV, E.B. BAGLAEV,**
G.V. SLAVIANSKIJ, E.A. MOKLOKOVA
Summary N 2136102

The engine is designed to propel a vehicle. The device consists of a microwave oscillator (1), a concentrated winding (2), in the form of a multi-layered cylindrical coil, made of a strip line and rigidly mounted with the frame of the vehicle being propelled, a core (3), electrodes (5) and a high-voltage block (5). During the discharge of the electric impulse of the high-voltage block, an electric arc appears, closing the output of the strip line. As a result of the load change, a transient process is initiated in the line, accompanied by the accelerated motion of the inertial mass, equaling the energy of the high-

frequency electromagnetic field in the strip line, this energy being received from the microwave oscillator. The impulse gravitational field generated by the inertial mass, which moves with acceleration in the strip line, creates vortex gravitational currents in the core and the respective impulse gravitational field or pressure varying with time. The force inside the core is directed to the opposite side, as compared to the force acting in the environment. According to the Law of Action and Reaction, the Earth's gravity field will create counterdirectional impulse gravitational fields, and, consequently, pressures. As a result, the motion of a vehicle can be observed. The speed of a vehicle can be regulated by controlling the output power of the microwave oscillator, while its direction and braking can be regulated by controlling the direction of the electromagnetic microwave energy power flow in the strip line.

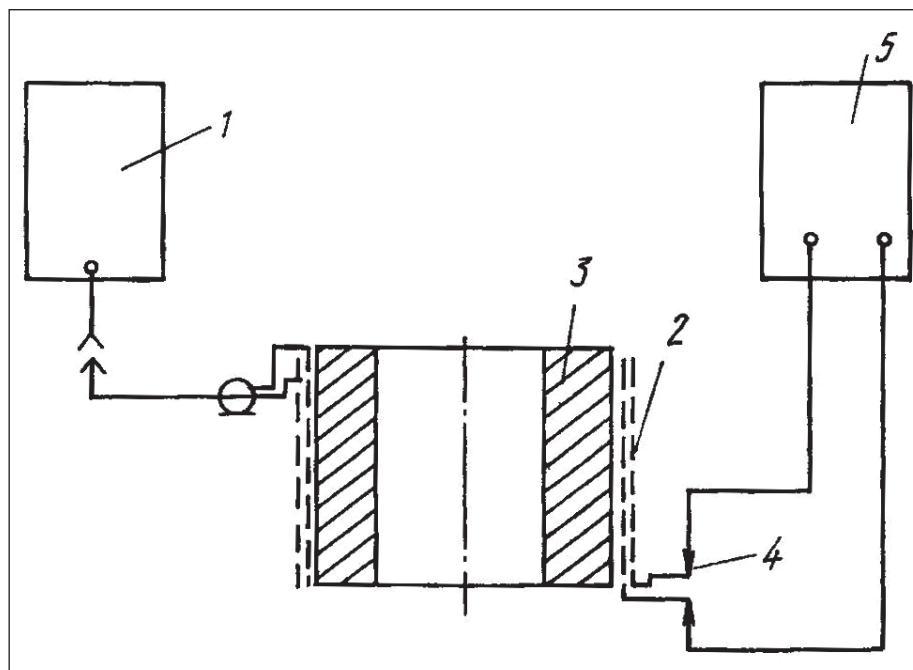

Fig. 1

“BREEZE 5000” Wind Energy Installation A New Approach To The Old Scheme

Toomas A. PUNGAS, Russia
“ELECTROSFERA” Holding Company
B. Sampsonievsky Av., 61
Saint-Petersburg,
Russia, 194044
www.elektrosfera.com
wind@esk.spb.ru
tel: (812) 324-48-88
fax: (812) 324-48-84

Wind energy was one of the first types of energy that man learned to use. For more than three thousand years, sailing vessels furrowed the seas while tens of thousands of wind mills were setting in motion mill burrs, pumps, saws and other mechanisms. A considerable part of the territory of the Netherlands was reclaimed from the sea by means of water-engines set in motion by wind.



With the invention of the steam engine and other machines operating on the principle of conversion of the burned fuel heat energy into mechanical or electrical energy, the use of wind energy started to diminish until, by the middle of the XXth century, it had almost disappeared on a global economic scale. It seemed that in a world where industrial capacities were measured by mega- and gigawatts there was no place

for such a low-grade energy resource as wind.

However, in the late 1970s wind energy underwent revival (in the West), caused by a worldwide energy crisis. Furthermore, it became obvious that a power industry based on the principle of burning fossil fuel, did not have any future, since its reserves are limited. The accident at Chernobyl deprived atomic energy of its status as a panacea for the energy hunger.

Today wind power engineering is one the most dynamically developing industries with multi-billion dollar turnovers in the countries of Western Europe and North America. But this is not true for Russia. It can be said that there is no such industry in Russia as wind power engineering, and there are objective reasons for this. First, the relatively low cost of both energy resources and electric energy in our country make the building of large wind energy installations (so-called “wind parks”) unprofitable. Besides, high power wind generators are intended for operation as integral parts of high-powered energy systems with stable parameters. Speaking about Russia, that would mainly apply to the central regions but they have insignificant wind resources.

At the same time, there is an objective necessity to build wind power generators in the regions of Russia where diesel generators are used for the power supply. These regions constitute about 60% of the territory of the Russian Federation with a population of 15 million people. These would be the regions of the Far North, Siberia and the Far East of Russia. The majority of these regions also have splendid wind resources.

Taking this into consideration, in 2002 the “Electrosfera” SPA came to a decision to design a low-cost and reliable wind power installation that could be

used as an integral part of a fully automatized wind-diesel electric power station or integrated into the already operating diesel electric power station.

Figuratively speaking, we did not mean to “invent the bicycle”. We simply designed a good “bicycle”. A wind power generator is the main (and the most expensive) component of the installation, and it has quite a traditional construction for modern wind generators, consisting of a three-bladed wind-wheel, transmitting rotation directly to a synchronous generator and interfering with the field of constant magnets. The principle of shifting of the wind generator to a diagonal current of air is used to limit the wind-wheel rotation speed and to protect the installation during storms. Aerodynamic and gravitational forces acting on the wind-wheel and the weathercock, which is free to move on the pintle, are balanced in such a way that when the wind reaches a speed of 15–16 m/s, the weathercock folds, putting the surface of the windwheel parallel to the air current.

The wattage was selected proceeding from the idea of serviceability in remote regions. A wattage of 5 kW is sufficient to serve a cottage or a small farm with electricity. On the other hand, the weight and dimensions of the wind power generator make it possible to assemble it without using a lift crane or other special equipment. If more power is required, wind power generators can be connected in parallel, thus creating installations reaching 10, 20 or even 50 kW. The use of several turbines instead of one, larger in size, increases the reliability and operability of the installation. The only disadvantage, lying in the need for a



larger area for the set-down, does not represent a problem for sparsely populated regions.

The electric energy generated directly by a wind power generator has unstable frequency and voltage. That is why it is used to charge an accumulator storage battery (as in the majority of analogous installations manufactured in other countries). The installation also comprises a charge regulator used to prevent the battery from overcharging, which can cause it to break down.

The accumulator voltage is transformed into a stabilized commercial frequency voltage (220 V) by means of an inverter. The shape of the wave is a “perfect” sine, which is one of the unique features of our installation, since the majority of foreign manufacturers of small-sized wind generators kit them up with transformers having a so-called “modified sine wave” on their output. This means that the voltage gets distorted by a large number of parasite harmonics, which sometimes may result in a malfunction or breakdown of the equipment, consuming electricity from such a transformer.

We realized from the very beginning that a diesel or petrol-powered generator should be an integral part of our installation. Indeed, a wind power generator itself cannot provide an uninterrupted power supply since even in the windiest areas no-wind periods, sometimes lasting for several days, may occur. To kit up the installation with a battery having a capacity high enough to provide the weekly amount of needed electric energy seems to be technically and economically unreal.

A diesel generator, as an electric energy source, besides the need to constantly fill its fuel tank, has another grave disadvantage. The problem is that both the technical and economic performance of aggregates of this type drastically drop when the load is not high enough (less than 15% of their nominal power). The fuel consumption per generation of 1 kWh of energy increases, and the aggregate’s units wear out more quickly. It is clear that it is quite difficult to provide

the constant load of a diesel generator, which will be no less than 50%.

However, introducing a diesel generator as part of a wind-diesel electric power station allows us to solve the problem fairly easy. We have designed a flexible programmable system for controlling the wind-diesel installation providing the following operation algorithm: when no wind is present, the load receives the electric energy due to the discharge of the battery. Then, when the battery voltage drops down to a certain design value, the diesel generator is started. The generator takes upon itself the load of consumers and then it is additionally loaded by the charging current of the battery in order to reach 80–85% of its nominal power. Then, when the battery gets charged, the diesel generator stops and the load is again directed to the inverter.

Such an algorithm to operate the wind-diesel electric power station allows achieving a cost of about \$0.03 per 1 kWh of the generated electric energy

(depending on wind resources), which can be compared to electricity charges.

Thus, the full configuration of the wind diesel power electric station comprises a wind power generator with a mast, a charge regulator, an accumulator battery, a diesel generator, a unit for controlling the joint operation of wind and diesel generators, and also a container equipped with an automatic temperature regime control system. We would like to stress once again that our installation may operate as an integral part of an already operating diesel electric power station.

Wind generators and “BREEZE 5000” installations are serially manufactured by the “Electrosfera” Company using Russian-made parts. Wind generators and wind-diesel installations are available at the company’s warehouses in Saint-Petersburg and can be delivered to the customer at the earliest possible date.

Silicon-Based Power Engineering

Extracted from: “Energetika i promishlennost Rossii” (“Russian Power Energy and Industry”) newspaper
<http://www.elec.ru/news/1036569497.html>

New revolutionary ideas have appeared in the field of modern energy: carbon and oxygen must be removed from the energy industry, while other chemical elements should be introduced. At a German chemical factory the “boiling” of silicon, which was stored in a form of fine powder in a nitrogen medium, was observed. Norbert Auner, a professor of Chemistry from Frankfurt, has announced that energy may be generated not only by traditional methods, that is by burning carbon in oxygen, but by using chemical interaction of other elements. A detailed investigation of this factory case showed that traces of copper oxide were present in one of the reservoirs that contained silicon powder and nitrogen. It is evident that the pure nitrogen that was present in the reservoir was also involved in the interaction. A reaction took place that was contrary to the experience of handling such an inert element as nitrogen. But the fact remains the same: the reaction did take place and on the day when the silicon started to “boil” it took great effort to still the “boiling” silicon powder. As it turned out, silicon may quite effectively combine with nitrogen. The temperature needed to start a reaction is 500 °C, the second condition being that the silicon has to be reduced down to a fine powder. Copper oxide acts as a catalyst. If silicon,

being a constituent part of sand, is so easy to ignite, does it not mean that this very chemical element will become mankind’s main fuel in the near future?

First, our planet is rich in sands. Second, the reaction of burning in nitrogen is not accompanied by the generation of greenhouse gases, oxygen dioxide being the main one. What remains after the new burning reaction is over, is sand, the main difference being that it is not oxygen-, but nitrogen-based sand. A perfect world of the future, which uses silicon as fuel, would look like this: man would abandon using coal and oil supplies, electric power stations would operate on a silicon powder, cars would be fueled by the same powder at service stations and would unload bags filled with “ash” at the same time. Certainly, it would be incorrect to declare sand “to be the oil of the future”, since it is not the sand that burns but silicon. Pure silicon is not present in nature — in order to get it from sand, a considerable amount of energy needs to be spent. This energy is mainly spent to separate oxygen atoms from silicon atoms. However, this energy expenses will be recompensed due to the high effectiveness of the process of combining silicon and nitrogen. Professor Auner assumes that it would be better to build factories for silicon revivification in equatorial deserts, which have all the necessary conditions for silicon manufacturing, that is sand, air, and solar energy. The latter, by generating current, will make silicon-restoring reactors work.

Of course, a large number of technological problems need to be solved. This process, in Auner’s estimation, will take ten to twenty years. This is how long it will take for technical ideas to develop into projects.

A method of extraction (restitution) of the energy supply stored in liquid or gaseous mediums and transformation of the energy obtained into mechanical work (Russian Federation patent N 2059110)

V.F. MARKELOV, Russia
Grajdansky Ave., 15-1, ap.147,
Saint-Petersburg
Russia, 195220

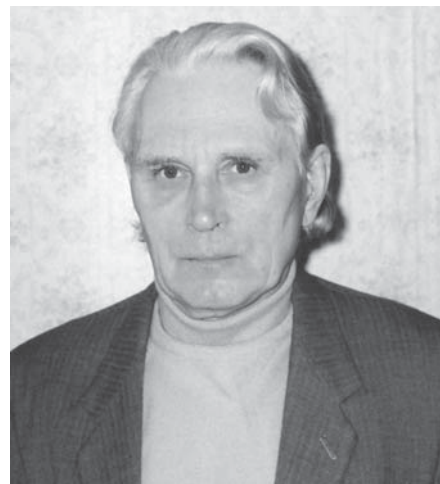

In 1607 Cornelius van Drebbel, a Dutch scientist, demonstrated a “continuously operating” clock to the English king James I. The clock was set in motion by a similar “continuously operating” motor, or, to put it simply, a “perpetuum mobile”. Van Drebbel had already patented the clock in 1598. However, unlike other numerous devices bearing the same name, the motor invented by Cornelius van Drebbel really was a “continuously operating” one in some sense.

What was the secret of this clock (or, rather, of the motor that was setting it in motion)? Van Drebbel’s continuously operating clock worked due to the drive, which used, like any other real motor, the single possible source of work – the non-equilibrium (potential difference) of the environment.

Van Drebbel made use of a special type of non-equilibrium, though it was also related to pressure and temperature differences. It may act in an ideally balanced environment, the temperature and pressure of which are everywhere equal. What is the secret of this effect and where does work come from?

The secret lies in the fact that potential differences do exist, manifesting themselves not spatially but temporally (*Editor: In my report, given in 1996 at the conference “New Ideas in the Natural Sciences”, I proposed a similar principle for obtaining energy from a single-wire power transmission line. Instead of a common potential difference $U=X_1-X_2$, I proposed a chroral potential difference $U=X(t_1)-X(t_2)$. This means that a potential difference may be obtained at a single point if a change in potential values is created*). The principle can be illustrated by the example of the atmosphere. Let us assume that no considerable pressure and temperature differences are observed in the area where a motor is situated. But the pressure and temperature (common in all points) still continue to change (both day and night). These differences may be used for obtaining work (in full accordance with the laws of thermodynamics).

In a description of the invention titled “A method of extraction (restitution) of the energy supply stored in liquid or gaseous mediums and transforming the energy obtained into mechanical work” (Russian Federation patent № 2059110) a version of a pseudo-continuously operating working solar engine was proposed by me. In order to increase the power and the number of cycles, the properties of two mutually unbalanced mediums – gas and water – are most fully used.

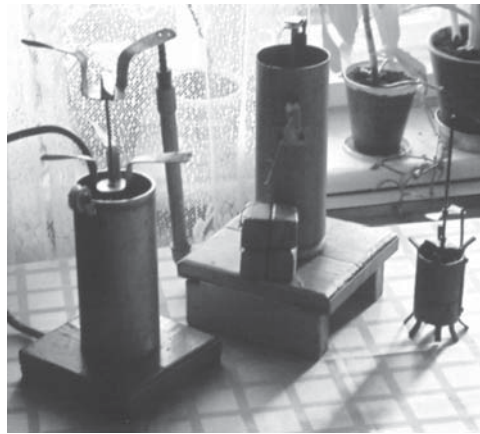

Photo 1

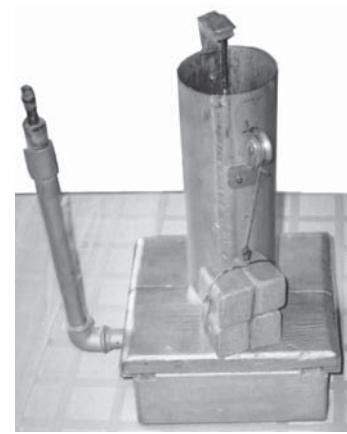

Photo 2

Archimedes' principle is considered as a corollary of the law of conservation of energy, in which the buoyancy force is tied in with the energy consumed to create water and air. The amount of this energy determined such physical properties as density, thermal capacity and thermal conductivity.

The correlation of energy used for creating densities is partially reflected in the non-equilibrium coefficient, equaling 820. If we found a way to fully use this non-equilibrium, we would obtain an 820-fold gain in energy. Non-equilibrium states are observed starting from the moment of feeding air under a column of water. They accumulate when the air rises because the air volume increases, taking away heat from the water. Air is fed under the water column at a temperature less than the temperature of the water, since if during the process of reaching atmospheric pressure the air pressure equals 4 Atm (0,4 MPa) and the temperature is +20°C (293 K), the air will cool down to -75°C (198 K), i.e. by 95°C. Heat extraction will take place in conditions close to adiabatic. This means that heat losses will be minimal due to the fact that water is a good heat accumulator but a bad heat conductor.

Calculation of an energy-extracting pneumohydraulic turbine

(Russian Federation patents N 2120058, N 2170364, N 2024780)

A compressor is used as a source of compressed air. Dynamic and positive displacement-type compressors are the most suitable for this case. Since

a dynamic compressor consumes more energy than a piston-type one, we choose the latter:

- Source of compressed air – VP2-10/9 piston-type compressor.
- Compressor output – 0,167 m³/sec
- Output pressure, MPa – 0.9 (9 Atm).
- Compressor's shaft capacity – 56.5 kW
- Water cooling

The efficiency of a pneumohydraulic turbine will be evaluated by comparing the power supplied and the power obtained, i.e. the amount of work per second.

A compressor's output is evaluated by the volume of air fed into it at atmospheric pressure. This means that a productivity of 0.167 m³/sec is the air volume before entering the compressor and after it rises in the turbine. While feeding air under the bottom level of the turbine, 0.167 m³/sec of water will be displaced through the upper level. The same amount of water will be fed again under the turbine's bottom level, thus creating an air-and-water mixture and causing it to move inside the turbine. The value of 0.167 m³/sec corresponds to the water consumption taken into consideration during the calculation of the capacity of a pneumohydraulic turbine. The capacity is calculated using the formula used for calculating the capacity of a hydraulic turbine:

$$N=9.81 \cdot Q \cdot H \cdot \eta,$$

where 9.81 m/sec² – the gravitational acceleration;

Q – the water consumption in m³/s;

H – the head in (m);

h – **Efficiency factor** (which reaches rather high values and amounts to 0.94–0.95 or 94–95% un-

der most favorable conditions). As an air-and-water mixture is used as the working medium, there is a necessity to justify the use of this formula for calculating the capacity of a hydraulic turbine. We believe that the most effective results can be obtained in the operation mode of the turbine when a mixture of a 0.5 t/m^3 density is used (comprising 50% water and 50% air). In this mode, the air pressure is a little higher than the absolute pressure inside the turbine case. Air is fed from the pressure tube of the compressor in the form of separate bubbles, which come out from it in equal intervals. The total volume of bubbles equals the volume of water between them in the turbine case. A bubble takes the shape of a spherical segment and works as a piston in a limited space, displacing water in an upward direction only, since its backflow is impossible due to the higher pressure, while its side-flow is impossible due to the incompressibility of water. If a constant volume of air of $0.167 \text{ m}^3/\text{sec}$ is fed, $0.167 \text{ m}^3/\text{sec}$ of water will be displaced. This means that $2 \times 0,167 \text{ m}^3/\text{sec}$ of the air-and-water mixture will be displaced through the upper level of the turbine, the stream velocity inside the turbine being high. Thus, we get:

$$N = 9.81 \cdot 2 \cdot Q \cdot 0.5 \cdot H \cdot \eta = 9.81 \cdot Q \cdot H \cdot \eta$$

Let us consider an installation with a head of water column equaling 2 m and calculate the compressor engine capacity needed to feed air under this water column, taking into consideration the atmospheric pressure, proceeding from the technical specifications of the compressor:

$$N = (2 \text{ m} \cdot 56.5 \text{ kW}) / (90 \text{ m} + 10 \text{ m}) = 1.13 \text{ kW}$$

A rising stream of an air-and-water mixture will be observed on all levels of the installation. No more than 5 working wheels may be installed along the stream due to the buoyant force the intensity of which does not depend on the depth of immersion of a body. The proposed turbine is more energy-efficient than the famous "Airlift" pump, since the flow of water takes place beneath the level of water in the turbine, i.e. in conditions close to zero gravity and without a considerable water level rise inside the turbine, on which the main



Photo 3

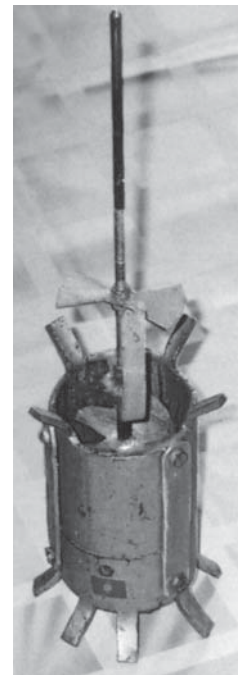

Photo 4

amount of pump energy is spent. Let us assume that the turbine's energy efficiency equals 0.9. In this case the capacity will be:

$$N = 9.81 \cdot 0.167 \text{ m}^3/\text{sec} \cdot 2 \text{ m} \cdot 0.9 = 14.7 \text{ kW}$$

Thus, we obtained output energy 13 times exceeding the input energy:

$$14.7 \text{ kW} / 1.13 \text{ kW} = 13$$

An increase in power by means of using additional working wheels has been observed on working prototypes. The operability of the turbine has been indirectly proven by experiments carried out at Saint-Petersburg State Technical University (SpbSU). Thus, Professor V.V. Elistratov, a Doctor of Engineering Sciences, a member of the Commission for Unconventional Power Sources in the government of the Russian Federation and head of the Department of Renewable Energy Sources and Hydroenergetics of SpbSTU wrote: "However, proceeding from the hydraulics of hydraulic units and our numerous experiments of feeding air into the working wheel of the turbine in order to reduce cavitation erosion, an increase of cavitation values was observed accompanied by a considerable decrease of energy values". In this case, the experiments show that the air that is fed into the device creates a counter stream, which, acting on the working wheel from below, makes it rotate in the opposite direction. Such is the design of the wheel. In such a way, a small volume of air acts in a limited space equaling the volume of the

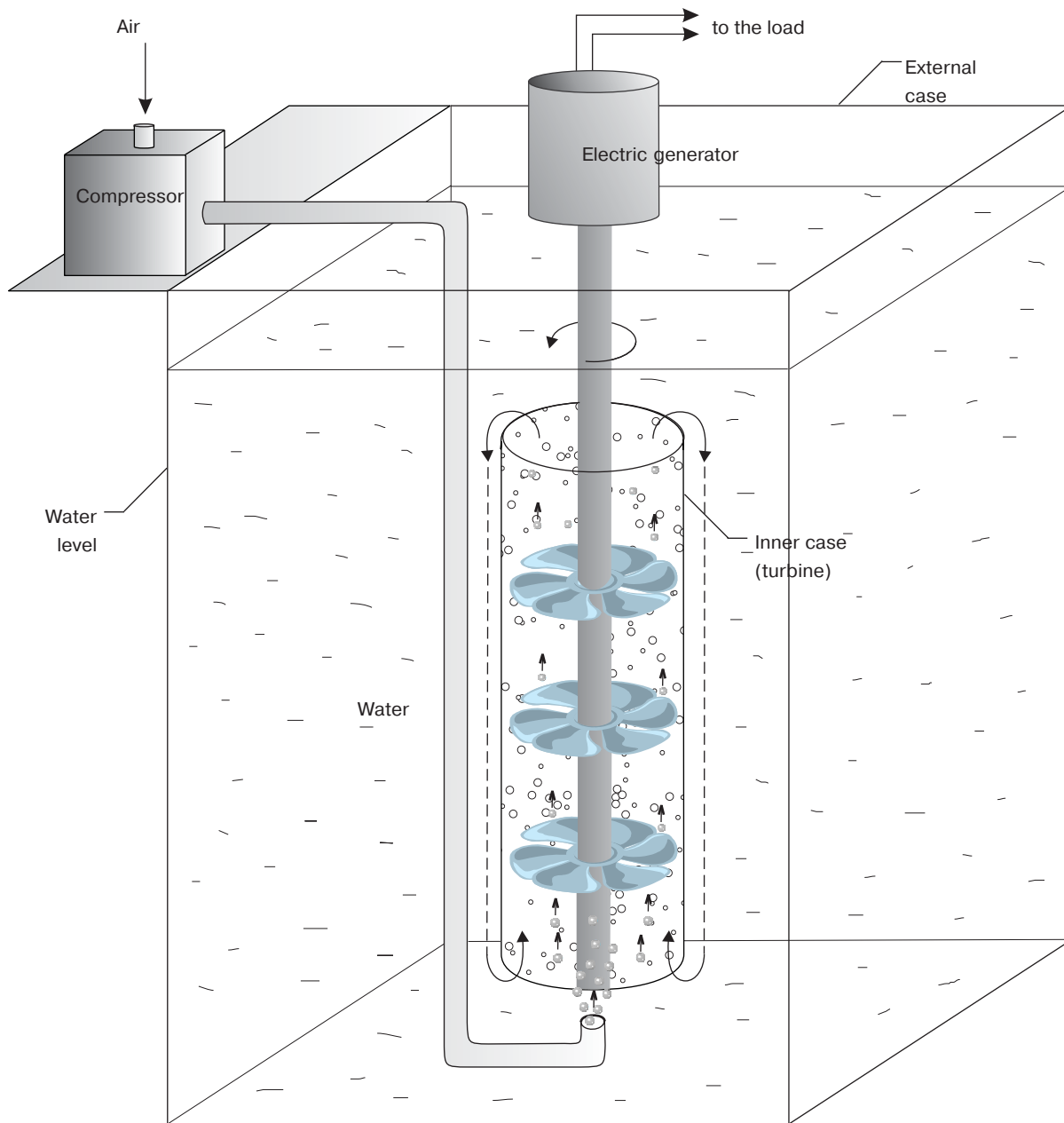

Fig. 1

hydro-turbine case. The proposed installation may extract heat from the water and transform it into mechanical energy. Taking into consideration the temperature difference between the water and the air when the water temperature equals 80°C (the thermal source, water, heated up in a solar collector or in a system of turbine cooling or compressor cooling, etc.), and the air temperature is 20°C, the coefficient of the air volume increase, according to the Gay-Lussac Law, will total:

$$1 + (80^{\circ}\text{C} - 20^{\circ}\text{C}) / 273 = 1.2$$

The capacity will amount to:

$$N = 14.7 \text{ kW} \cdot 1.2 = 17.6 \text{ kW}$$

Our expectations about a gain in energy were borne out:

$$17.6 \text{ kW} / 5 = 3.5 \text{ kW}$$

3.5 kW / 1.13 kW = a 3,1-fold energy gain per wheel

During the calculation of the power needed to feed air under the water column, we took the atmospheric pressure into consideration (1 Atmosphere = 10 m of the water column). This means that the rising air overcomes the absolute pressure inside

the turbine case. The pressure, composed of the water column pressure in the turbine and the atmospheric pressure, equals the pressure of a 12-meter water column. The absolute pressure inside the turbine case is neutralized by the buoyancy force of the air, but since it is still present outside the case, it influences the feeding of air into the turbine. This influence can be compared to the influence of the negative pressure created in the turbine case by the total volume of water inside it on the water stream (this effect is not present in other hydroturbines). If the construction of the turbine meets out requirements, we can consider the head as:

$$H = H \text{ of water column} + 10 \text{ m}$$

Then the power will total

$$N = 9.81 \cdot 0.167 \text{ m}^3/\text{sec} \cdot 12 \text{ m} \cdot 5 \cdot 1.2 \cdot 0.9 = 106.14 \text{ kW}$$

We obtained output energy 93 times greater than the input energy.

Let us calculate a more powerful energy installation able to power a small urban village, military unit, a vessel etc. A 2VM10 – 63/9 piston-type compressor with the following technical specifications will be used as the source of compressed air:

- Compressor output – 1.04 m³/sec
- Output pressure, MPa – 0.9 (9 Atm)
- Compressor shaft power – 332 kW
- Water cooling

A calculation will be carried out for an installation with a head of water column equaling 5 m and with 10 working wheels installed inside at a distance of 500 mm from each other. The capacity of the compressor motor needed to feed air under a 5-meter water column, taking into consideration the atmospheric pressure, is:

$$5 \text{ m} \cdot (332 \text{ kW} / 100 \text{ m}) = 16.6 \text{ kW}$$

The installation capacity will total:

$$N = 9.81 \cdot 1.04 \text{ m}^3/\text{sec} \cdot 15 \text{ m} \cdot 10 \cdot 1.2 \cdot 0.9 = 1652 \text{ kW}$$

We obtained output energy exceeding the input energy by a factor of 99.

Thus, the obtaining of any amount of energy is possible, accompanied by an improvement in the gaseous water composition by means of an environmentally friendly method. This method implies the use of an inexhaustible energy source, when a natural non-equilibrium of water and air is used in any climatic zone. There is no need any more to build expensive dams and sluices, which leads to flooding of valuable agricultural lands.

Calculation of an energy-extracting pneumohydraulic engine

(Russian Federation Patents N 2003830, N 2160381)

- Source of compressed air – VP2 – 10/9 piston-type compressor.
- Compressor output – 0.167 m³/sec
- Output pressure, MPa – 0.9 (9 Atm).
- Compressor shaft capacity – 56.5 kW
- Water cooling

The efficiency of a pneumohydraulic engine will be evaluated by comparing the power supplied and the power obtained, i.e. the amount of work per second. The compressor output is the volume of air on the compressor's input, i.e. the volume of air at atmospheric pressure. Then the value of 0.167 m³/sec is the volume of air on the compressor input and on the exit from the upper float of the pneumohydraulic engine (Fig. 3). Floats are released from the air and then filled with water at a level that is situated below the level of water in the engine case. At an air pressure of 9 Atm it may be fed under a water column with a head of 90 m. If the air bubbles rise at a speed of 0.4 m/s, it will take 225 sec for a bubble to reach the surface. Moving air will be present at all levels of the water column. This figure of 0.4 m/s was obtained during experimental evaluations. If the water column and compressor output remain stable, an increase or decrease in speed at which the bubbles rise, results only in a change in the horizontal dimensions of the floats (their length and width), since it is the air volume that increases or decreases. This, in turn, only increases or decreases the force, not influencing the capacity of the pneumohydraulic engine. The possibility to change the horizontal dimensions of the floats allows making floats of a needed volume preserving the water column.

The volume of air on the output of the compressor's pressure tube at a depth of 90 m will total (taking into consideration the atmospheric pressure):

$$0.167 \text{ (m}^3/\text{sec)} / 10 \text{ Atm} = 0.0167 \text{ m}^3/\text{sec}$$

since the pressure of a 10-meter water column will equal 1 Atm and due to the fact that an increase in the volume of air by the value of the initial volume takes place every 10 meters the air rises. If the air volume remained permanent, at the moment of reaching the surface its volume would be:

$$0.0167 \text{ (m}^3/\text{sec)} \cdot 225 \text{ sec} = 3.757 \text{ m}^3$$

Taking into consideration the volume of air at the moment it reaches the surface, its total volume will amount to:

$$3.757 \text{ m}^3 \cdot 10 \text{ Atm} = 37.57 \text{ m}^3$$

Taking into consideration the coefficient of thermal expansion, its volume will total:

$$37.57 \text{ m}^3 \cdot 1.2 = 45.084 \text{ m}^3$$

The buoyancy force of a 1 m^3 of air equals 1000 kgf

The amount of work performed by this volume of air as it rises will amount to:

$$45084 \text{ kgf} \cdot 0.4 \text{ m/sec} = 18\,033 \text{ kgf} \cdot \text{m/sec}$$

or $18033 \text{ kg} \cdot \text{fm/sec}$

Since $1 \text{ kg} \cdot \text{fm} = 9.81 \text{ W}$, the result of recalculation is the following:

$$18033 \text{ kg} \cdot \text{fm/sec} \cdot 9.81 = 176903.73 \text{ W} \text{ or } 176.9 \text{ kW}$$

By adding no less than 30% of the energy that is returned, obtained due to the reactive force that is created during the filling of a float with air, to the energy that is received, we get:

$$176.9 \text{ kW} + 18 \text{ kW} = 194 \text{ kW}$$

We obtained the output energy exceeding the input energy by a factor of 3.4.

The mechanical energy efficiency of a pneumohydraulic engine will be rather high since during operation the engine is well lubricated by water, while the floats are mutually balanced. The energy efficiency of the compressor is taken into account during consideration of the compressor's engine capacity. The pneumohydraulic engine is equipped with a brake that makes it stop during operation. When the engine stops, air is still present in the floats, which means that no energy will be consumed on the next start-up since the engine will be put in operation by the air left in the floats.

In our calculations, we proceeded from parameters of a serially produced compressor, able to feed air under a water column with a head of 90 m. This is a way to increase the effectiveness of hydroelectric stations by means of installing pneumohydraulic engines in pontoons at water-storage ponds. Increasing the effectiveness of hydroelectric stations by using tail ponds is considered in the description of the invention № 2059110. The design of the pneumohydraulic engine is remarkable for its low steel intensity, thus making it very light. Any river, pond, spring, thermal source or cooling tower may become a source of energy. A leveling of the water temperature at hydroelectric stations will become possible by means of blending lower, more warm water sheets and cold

upper water sheets. The process will be accompanied by a simultaneous extraction of heat from the water. The most important point is that there will be no need to economize energy, since we do not amplify the natural energy imbalance by using a natural non-equilibrium. On the contrary, we restore it by getting rid of the consequences of thermal pollution. As for the solar energy, we do not spend more of it than we obtain.

We considered a method of obtaining energy in industrial conditions, but there is a great need for energy installations with a wattage of 3-4 kW. Let us try to estimate their sizes. Take an installation with a head of water column equaling 2 m. Using the same type of compressor (only for calculation) we may find out the capacity of the compressor engine needed to feed air under a 2-meter water column:

$$N = (2 \text{ m} \cdot 56.5 \text{ kW}) / (90 \text{ m} + 10 \text{ m}) = 1.13 \text{ kW}$$

The compressor output – $0.167 \text{ m}^3/\text{sec}$

A 2-meter water column creates pressure equaling 0.2 Atm. Then the water volume at a depth of 2 m will amount to (taking into consideration the atmospheric pressure):

$$0.167 \text{ (m}^3/\text{sec)} / 1.2 \text{ Atm} = 0.139 \text{ m}^3/\text{sec}$$

The time needed for a bubble to rise equals:

$$2 \text{ m} / 0.4 \text{ (m/sec)} = 5 \text{ sec}$$

The volume of moving air that will be present in the floats of a pneumohydraulic engine in 5 seconds (taking into account the increase in volume as the air rises and the thermal expansion coefficient) will total:

$$0.139 \text{ (m}^3/\text{sec)} \cdot 5 \text{ sec} \cdot 1.2 \text{ Atm} \cdot 1.2 = 1 \text{ m}^3$$

The amount of work performed will amount to:

$$1000 \text{ kgf} \cdot 0.4 \text{ m/sec} = 400 \text{ kg} \cdot \text{fm/sec}$$

The amount of work per second equals the power. Since $1 \text{ kgf} = 9.81 \text{ W}$, the capacity will be:

$$N = 9.81 \text{ W} \cdot 400 = 3924 \text{ W} = 3.924 \text{ kW}$$

By adding 30% of the power returned, we get:

$$3.924 \text{ kW} + 0.34 \text{ kW} = 4.263 \text{ kW}$$

If the mechanical energy efficiency equals 0.9, we get the following capacity:

$$N = 4.263 \text{ kW} \cdot 0.9 = 3.84 \text{ kW}$$

We obtained output energy exceeding the input energy by a factor of 3.4:

$$3.84 \text{ kW} / 1.13 \text{ kW} = 3.4$$

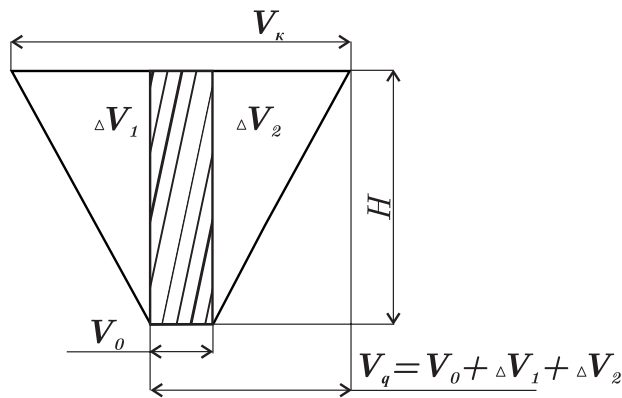

Fig. 2 a

In order to once again make sure of the effectiveness of the proposed method of obtaining energy, let us compare its effectiveness with that of a storage plant, in which water is pumped to a high-level storage pond by means of a pump or a reversible hydroset and then used at a lower level in a turbine. In this case, if the energy efficiency factor amounts to 100%, it means that we obtained an amount of energy that equals the amount of the energy consumed. Let us calculate the capacity of a pump engine needed to lift water to the level of 90 m, the output of which is 0.167 m³/sec:

$$N = (9.81 \cdot 0.167 \text{ m}^3/\text{c} \cdot 90 \text{ m}) / 0.75 = 196.5 \text{ kW}$$

Let us compare the power obtained by a pump engine to that obtained by a compressor engine with a capacity of 56.5 kW and air output of 0.167 m³/sec. The latter can displace the same amount of water, lifting it to a level of 90 m and feeding it to a turbine. An amount of power equaling 196,5 kW is obtained, which means that 3.5 less energy is spent. Besides, the moving air that remains throughout the head of the water column will also perform work, which is confirmed by the aforementioned calculation. The possibilities of implementation of the proposed method are reflected in the diagram shown below (Fig.1)

It can be seen from this diagram that the buoyancy force manifests itself starting from the volume V_0 . The cross-hatched part of the picture is a water column H , to overcome which the energy generated by the compressor is spent. V_0 is the volume of water at a depth of H ; V_k is the volume of air, expanded due to the fall in pressure as air rises. V_q is the active air volume. The diagram shows that the volume of active air in a pneumohydraulic engine equals V_q , while the volume V_k is essential for a pneumohydraulic turbine, since it operates on a displaced volume of water. This fact explains the difference in their effectiveness.

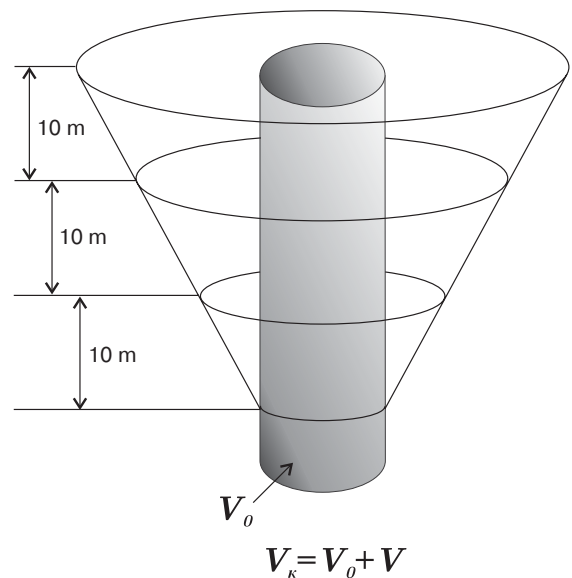

Fig. 2 b

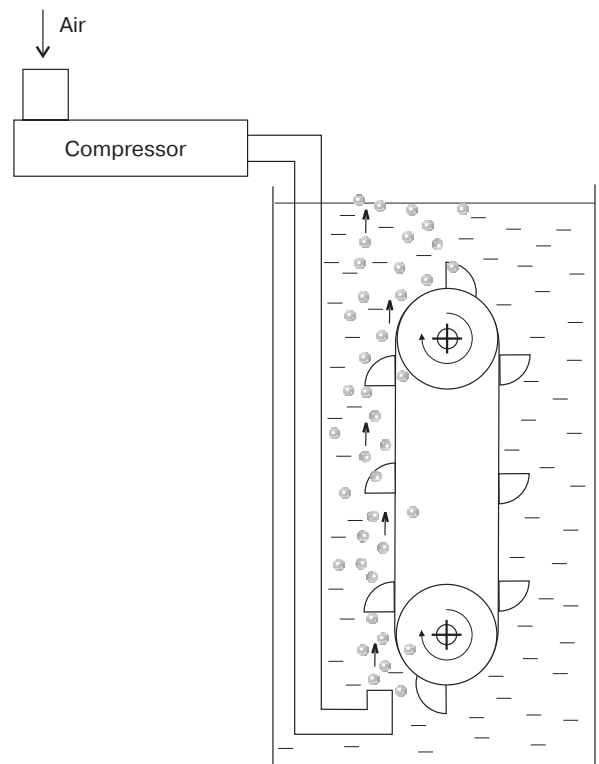

Fig. 3. A scheme of a generator based on floats

The inexhaustibility of the energy source, its absolute environmental friendliness, the ease of production and quick payback due to the ever-growing need for energy provide for effective marketing of the proposed construction, while the diversity of designs provide for a wide area of application.

Asymmetric Capacitors

Alexander V. Frolov

Faraday Lab Ltd.
7-812-3803844
<http://www.faraday.ru>



Although electric gravitation was studied from 1927–1965 by Thomas Townsend Brown, modern experiments with asymmetric capacitors became widely known only in the 1990s due to the “Lifter” project. What is the history of these experiments and which line of the research seems to be more promising? Some considerations concerning this issue are given below.

I have performed several experiments in my laboratory since 1994. The conception lies in the idea of getting an asymmetric vector composition of forces. In the classic design of a flat capacitor, for example, the plates are attracted towards each other, but the forces are opposing while the resulting force equals zero. In the T-capacitor, which I designed in 1994, two electrodes were situated in the same plane. This is why the result is a non-zero propulsion force.

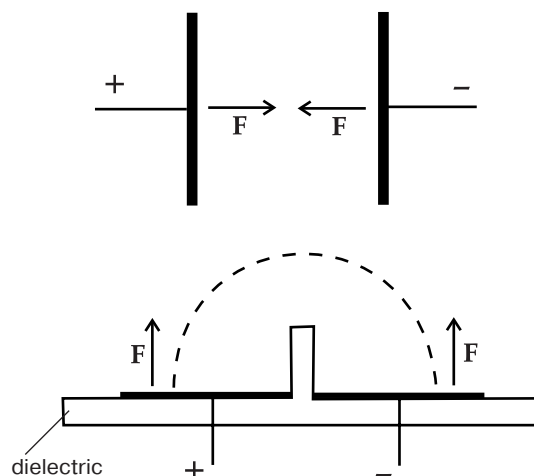

Fig. 1

The electrodes are separated by a “dielectric wall” to exclude the possibility of electric discharge along the minimal distance between the electrodes. The electric field structure is configured here to create co-directed electrostatic forces for both electrodes.

A few words about patent priorities. In 1994 an article of mine containing a description of the present principle was published in the USA in the *New Energy News* magazine, May, 1994, pages 1–5. Later the article was also published in the *Newsletter of Planetary Association for Clean Energy*, vol. 8(1), September 1994. The article was edited by Thomas E. Bearden. In that article I described the principles of using electric fields that make it possible to create a propulsion force. Here is a quotation from my article concerning the issue of asymmetric capacitors:

“In order to find a solution and to create a unidirectional resulting thrust, we should take into consideration that the potential field force lines are always perpendicular to a charged surface”.

The experiments were shown to specialists of a Japanese company, who came to Saint-Petersburg for a visit. Some of the basic experiments are shown in Fig. 2.

Later on, a French research group (headed by Jean Louis Naudin) also experimentally proved the present principle and started research on the practical application of the technology, not going deeply into the phenomenon’s essence. Their web-site is www.jnaudin.free.fr

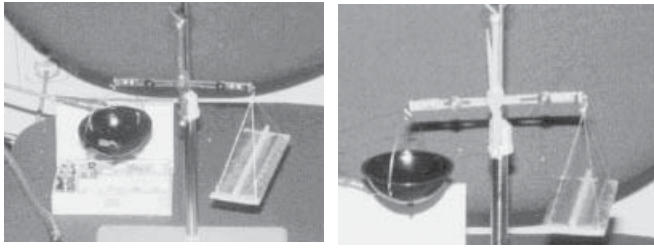

Fig. 2. A slight change of the T-capacitor's weight can be observed using primitive scales.
The capacitor is connected to a 10kV power source.

pany can be found on their web-site: www.tdimension.com/press_releases/press_release_6_25_01.html

The present technology is too complex for commercial application due to the need to use high-voltage equipment. You may try to calculate the dimensions and voltage of a 1000-kilogram asymmetric capacitor for business applications yourself. I believe that this path is not leading us anywhere. A new solution needs to be found.

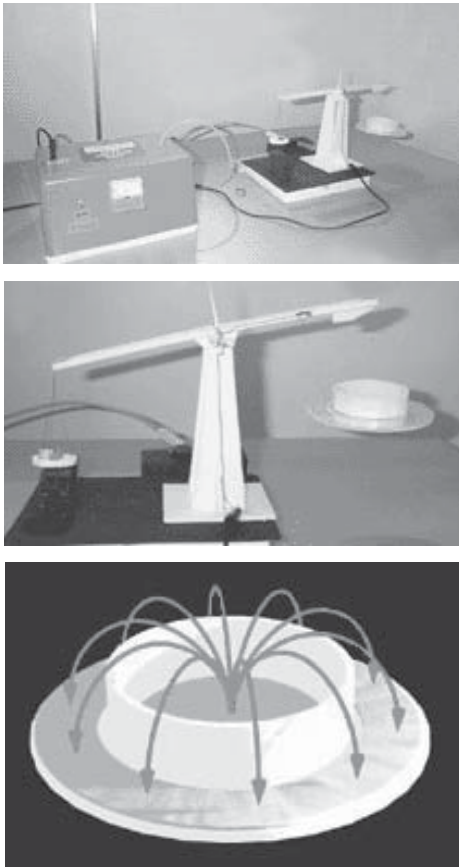

Fig. 3. Jean L. Naudin's version of Frolov's Capacitor

In the beginning, the asymmetric capacitor was called "Frolov's Hat" (its scheme is shown in Fig. 3), but recently the design has been simplified. Now a scheme consisting of two electrodes, one of which is a thin wire while another is metal plate, is being developed, Fig. 4.

The present technology is also being developed by the Transdimensional Technologies Company, USA. The research is supported by NASA and patents have been obtained. News from this com-

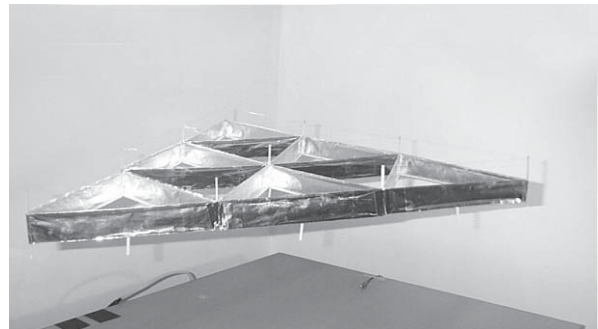

Fig. 4. In the present version, Jean Louis Naudin uses a thin wire and a metal plate as two asymmetric electrodes

In 1995, I suggested a design of an asymmetric capacitor filled with a liquid dielectric. During our first experiments positive results were achieved. The proposed design (a can filled with a liquid oil dielectric) is shown in Fig. 5:

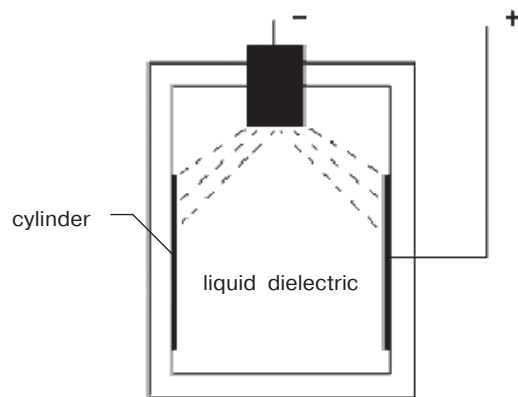

Fig. 5

A force totaling 0.4 gram was registered between the electrodes with a voltage of 10 kV. An evaluation was performed using HL400EX-type digital scales.

The research on a solid gradient dielectric seems to be the most promising. It is quite difficult for our small private company to bring the idea to life since the task to be implemented lies in the creation of a gradual change of permittivity in the dielectric between the plates of the capacitor. We are sure that our work has great commercial prospects and, therefore, continue experimenting. Calculations show that if a 10 kV power source is used, the design force amounts to 80 tons with an area of 100 sq. meters. If a high-quality dielectric is used in the capacitor, the power source's current drain could be minimal. These principles were reported at a congress held in 1998 in Saint-Petersburg, Russia. The present report was published in a book called "Fundamental Problems of the Natural Sciences", vol I, pp. 195–200, 1999, Saint-Petersburg, Russian Academy of Sciences and

Saint-Petersburg State University Publishers. A.V. Frolov.

We are also continuing our research of the T-capacitor; an application for a patent has been filed. I believe that the details of the invention should not be considered until positive results of a patent examination have been achieved. After the acquisition of a patent, we shall develop partnership relations with different organizations aimed at commercialization of the invention. The end product will represent a thin (about 1 millimeter thick) flexible film, the structure of which realizes the T-capacitor principle. This film is to be manufactured by means of the modern electronic industry. When the power is on, a thrust will be generated in a direction perpendicular to the film surface.

Our company is interested in developing partnership relations with potential customers.

Force On An Asymmetric Capacitor

Thomas B. BAHDER, Chris FAZI

Army Research Laboratory

Tech Report No. ARL-TR-3005, June 2003

(extracted from an Internet-source)

When a high voltage (~30 kV) is applied to a capacitor whose electrodes have different physical dimensions, the capacitor experiences a net force toward the smaller electrode (Biefeld-Brown effect). We have verified this effect by building four capacitors of different shapes. The effect may have applications to vehicle propulsion and dielectric pumps. We review the history of this effect briefly through the history of patents by Thomas Townsend Brown. At present, the physical basis for the Biefeld-Brown effect is not understood. The order of magnitude of the net force on the asymmetric capacitor is estimated assuming two different mechanisms of charge conduction between its elec-

trodes: ballistic ionic wind and ionic drift. The calculations indicate that ionic wind is at least three orders of magnitude too small to explain the magnitude of the observed force on the capacitor. The ionic drift transport assumption leads to the correct order of magnitude for the force; however, it is difficult to see how ionic drift enters into the theory. Finally, we present a detailed thermodynamic treatment of the net force on an asymmetric capacitor. In the future, to understand this effect, a detailed theoretical model must be constructed that takes into account plasma effects: ionization of gas (or air) in the high electric field region, charge transport, and resulting dynamic forces on the electrodes. The next series of experiments should determine whether the effect occurs in a vacuum, and a careful study should be carried out to determine the dependence of the observed force on gas pressure, gas species and applied voltage.

Frolov's T-capacitor And Its Working Principle

Zoltan LOSONC, Hungary
e-mail: feprinciples@on.mailshell.com

The Frolov's T capacitor was invented several years ago but its working principles are still not correctly understood by the researchers. Since even the brief original explanation of the working principle given by Mr. Frolov on his site did not present the real source of thrust, the correct principle and theory will be given in this paper.

The origin of the idea

The basic concepts of the T capacitor can be found in the work of T. Townsend Brown in the field of E-field propulsion. In his patent of 'Electrokinetic Apparatus' US 3,187,206 granted on June 1, 1965 the following important declarations laid the ground for the device:

- *"This invention relates to an electrical device for producing thrust by the direct operation of electrical fields. I have discovered that a shaped electrical field may be employed to propel a device relative to its surroundings in a manner which is both novel and useful..."*

This statement declares the discovery that a unidirectional thrust can be produced exclusively by shaping the electrostatic fields, or with other words by employing special E-field- and charge distri-

bution within and around the device. The effect does not require the reactive force of ions, or other physical objects moving in opposite direction around the thruster.

- *"The propelling force however is not reduced to zero when all environmental bodies are removed beyond the apparent effective range of the electrical field".*

Here it is confirmed that the created thrust does not require any physical matter nearby to provide a reaction force and base. Thus the developed thrust can be named reactionless force within the physical frame of reference (the reaction background is represented by the ether that can be considered belonging to a subtler dimension).

- *"Recent investigations in electrostatic propulsion have led to the discovery of improved devices for producing thrust by the use of electrical vectorial forces".*

This sentence postulates that the thrust is generated purely by the electrical field (or force lines), that is a vector field and also a force field (unlike the magnetic field). It is several times emphasized in the patent that the unidirectional thrust is achieved by creating an asymmetrical E-field distribution that produces asymmetrical electrostatic forces. Thus the art of producing effective E-field propulsion is defined as finding a way to create asymmetrical E-field — and electrostatic force distribution.

Mr. Brown has proposed several embodiments that realize this concept, specifically the following thruster type can be considered as the basis for the T capacitor (shown in *fig. 8.* in the original patent), that is presented on the figure below:

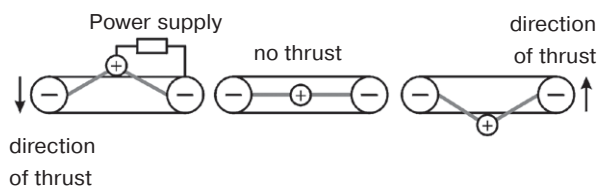

Fig. 1. Brown's electrokinetic thruster

It is described in the patent as follows:

- *“In accordance with still other aspects of this invention an annular electrode member is secured to an electrode mounted in the region of the axis of the annular electrode. If the second electrode is located at the center of the annular electrode and the two electrodes are energized such force is not detected. However, if the second or innermost electrode is displaced from the center of the annular electrode in the region of the axis of the annular electrode and the electrodes are energized, then the thrust will be produced by the two electrodes. The annular electrode may either be a flat ring, a toroid, or a section of a cylinder”.*

Thus by taking the two dimensional variant, when the outer electrode is a flat ring and the inner electrode is a flat disc, then we get the planar electrodes of the T capacitor specifically its circular “hat” variant. (*Comment: this design was used by French researchers who named it “Frolov’s capacitor”. But it is not exactly true. I recommend reading my article about Frolov’s T-capacitor.*) The E-field distribution should be asymmetrical in order to obtain a unidirectional thrust, and this asymmetry has been achieved in Brown’s patent by moving the central disk electrode above or below the plane of the ring.

The T capacitor design and the unclear principles

The originality of the Frolov’s T capacitor is in the different idea of achieving the asymmetry of the E-field. He keeps both electrodes in the same plane, thinking that by placing a sheet of dielectric under the electrodes will weaken the E-field intensity at the bottom of the electrodes (at least this is what his drawings suggest and how most researchers interpret the main principle). Thus the supposed electrostatic pressure and forces will be weaker on the bottom surface than on the top surface of the electrodes. This way the asymmetry is established and an upward resultant unidirectional reactionless thrust is expected. The original drawing of the T capacitor borrowed from Mr. Frolov’s site is shown on the following figure:

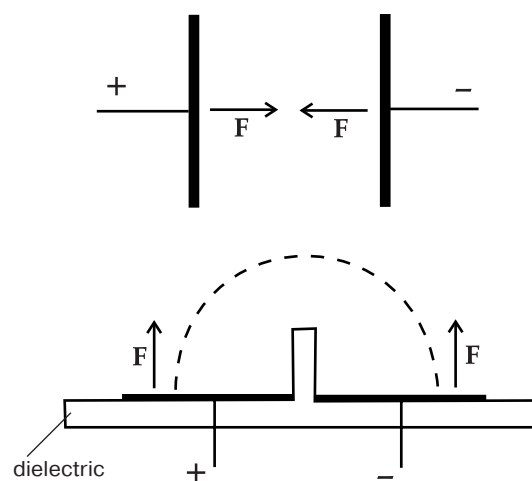

Fig. 2. The original drawing of the T capacitor

Mr. Frolov has given the following explanation about its working principle on his page titled **“proposals for experimental research on propulsion systems”**:

“Electrodes are separated by “dielectric wall” to exclude electric discharge along minimal distance way between electrodes. The electric field structure is configured here to create co-directed electrostatic forces for both electrodes. In microstructure version of this system the operational voltage can be de-

creased. E-shape dielectric structure is optimal for this case”.

Since the experiment demonstrated a unidirectional thrust, it is obvious that co-directional resultant forces must exist on both plates, but it does not explain its working principle. It is not explained how (based on what effect or mechanism) is the electric field structure configured to create these co-directional electrostatic forces, and what is the shape and intensity of the E-field below the electrodes. The dotted semicircular line above the electrodes on the figure represents the E-field, and it suggests the reason and the way these co-directional forces are created. Mr. Frolov has obviously suggested that these forces are nothing else but the electrostatic pressure forces acting upon the surface of the electrodes. Since the electrodes are made of conductors and the E-field lines are always perpendicular to the surface of the conductors in electrostatics, it will be clear that only upward, co-directed forces will act upon the **upper** surface of the electrodes.

However, no electric field lines and no forces are shown on the **bottom** surface of the electrodes, and they are assumed not to exist, or if they exist it is supposed that they must be much less than those above the plates and they have been neglected. The electric field shape and intensity below the electrodes are not discussed in the original presentation, nor the existence of additional forces upon the dielectric is mentioned (*Comment: It is not unmentioned but still it is not covered in the open press. This issue is the know-how of the invention. A.V. Frolov*). The area below the electrodes has been completely neglected, although this area is the key for creating the asymmetry, unidirectional reactionless thrust, and for the development of efficient thrusters.

The detailed explanation of the real principle

In order to understand the working principle and find the source of the detected thrust we have to know at least the approximate form of the E-field within and around the

thruster. For easier understanding let us consider first a T capacitor, which has a very thick layer of dielectric below the electrodes. If the thickness of this layer is about the size of the width of electrodes (or thicker) then we can assume that the whole space below the electrodes is filled with the dielectric, since the shape of the E-field will be the same with good approximation. Let's name this case as 'thick T capacitor'. The shape of the E-field will be approximately as shown on the following figure:

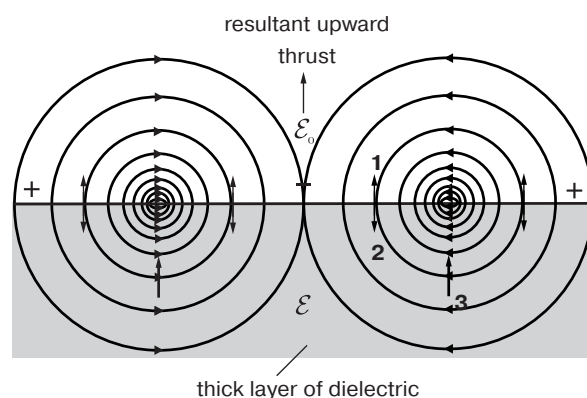

- 1 — top EP forces;
- 2 — bottom EP forces;
- 3 — dielectrophoretic EE forces.

Fig. 3. The cross section of the thick T capacitor

(Comment: there is no T-shaped dielectric on Fig.3! Where is the vertical wall between the plates? A.V. Frolov).

This E-field shape is specially valid for a section of the series of strip like T capacitors placed side by side with alternating positive and negative electrodes, and also for the 'hat' version using disc and ring electrodes (in that case some extra lines should be added at the ring's outer edges, but they make no difference). The dielectric wall above the electrodes has the only purpose to prevent discharge and it does not alter the shape of the E-field significantly (specially if it is thin and of low dielectric constant), therefore it is neglected in this explanation. (*Comment: It is not true. This mistake reveals the author's misunderstanding of the T-capacitor's working principle. A.V. Frolov*)

The shape of the field lines above the electrodes is semicircular that is gradually distorted into ellipsoid form very close to the inner edges, and finally merges into a straight horizontal line connecting the two edges along the shortest path. The changing intensity of the electric field is roughly indicated by the density of the field lines, and it is higher close to the inner edges and lower farther away from that point.

The intensity of the E-field is determined by the potential difference between the electrodes and by the length of the specific E-field line. The potential difference between two points is determined by the line integral of the E-field vector's and the elementary displacement vector's scalar product.

With simple words in this specific case it means that since the potential difference between any point on one electrode and any point on the other electrode is the same, and if the examined field line is longer, then its intensity must be lower to give the same product (and integral). This way it is obvious that the E-field intensity of the shorter semicircles close to the inner edges should be stronger, and that of the longer field lines farther away from the facing edges weaker.

The only forces present above the electrodes are the electrostatic pressure (EP) forces that act on the surface of the conductor plates and they are perpendicular to the surface, pointing upwards on both electrodes (codirectional). The intensity of these forces can be calculated after determining the surface charge density (or E-field intensity) in each point on the electrodes and integrating the product of the local electrostatic pressure and the elementary surface areas for both electrodes:

However, this upward force will be effective only if the downward force present on the bottom of the electrodes will be smaller than this force. As the above figure indicates the E-field lines below the electrodes within the dielectric have the same shape as above the electrodes. Since the potential difference between the electrodes is the same as above the plates and the symmetrical geometry creates

E-field lines of the same length as on the top, the E-field intensity is the same as above the plates. Although the originally declared and assumed working principle would require and predict an asymmetrical E-field distribution, and a weaker E-field intensity below the electrodes this is obviously not realized in this case.

After realizing that the E-field shape and intensity is symmetrical to the horizontal plane of the electrodes and it is the same below and above the electrodes (*Comment: it is true for the scheme shown in Fig.3 but not for the T-capacitor. A.V. Frolov*), the question arises whether the EP forces will be also identical and cancel each other. If this would be the case then there would be no resultant unidirectional thrust present on the thruster. Let us see the magnitude of the EP forces on the bottom of the electrodes. They are calculated in similar way as previously for the top of the plates but using the absolute dielectric constant ϵ of the dielectric in the formula instead of the dielectric constant of the air ϵ_0 .

Although the E-field intensity is the same as above the electrodes, the surface charge density s will be greater than on the top surface of the electrodes. The increased surface charge density is caused by the property of the dielectric to bind more electric charge on its surface at the same E-field intensity than what would be possible in vacuum. Comparing the bottom- and top forces we get the ratio of $F_b/F_t = \epsilon/\epsilon_0 = \epsilon_r$ that means, the force at the bottom pulling the thruster downwards is ϵ_r times greater than that on the top of the electrodes. Thus the EP forces on a thick T capacitor produce a downward resultant thrust.

This finding is quite surprising, since according to the original assumptions exactly the opposite was expected, namely a resultant upward force and a weaker E-field below the thruster, that is not true in this case. The strange thing is that even the experimental observations indicated an upward resultant thrust. Where is the mistake in the above analysis?

There is no mistake in the discussed analysis. Although the experimental observation

showed an upward resultant thrust, it does not mean that this resultant thrust can be composed only of these two force components. If there is an additional upward force component that is greater than the calculated sum of EP forces, then the resultant observable thrust will point upward. Let us see what can be the source of such unexpected upward force component.

The new force component and new E-field thruster principle

The E-field thrusters invented by Brown, Frolov and other inventors were based on the previously declared key principle first recognized by Brown, that a reactionless unidirectional thrust can be created by establishing an asymmetry of the electric field in the thrusters. This can be accomplished either by geometrical asymmetry of the electrodes or by asymmetrical utilization of dielectrics. This principle derives its forces from the electrostatic Coulomb (EP) forces acting on uncompensated surface charges on the electrodes or space charges within the nonlinear dielectrics.

The new force component that was not recognized and explained in detail so far by others in E-field thrusters is the dielectrophoretic force component that acts on the electrically neutral body of the dielectric. The basic mechanism of dielectrophoretic forces has been described on the tutorial page [dieltutor.htm](#). As it is demonstrated on *fig. 5a.* on that page there are two main forms of manifestation of these forces. In the first case the E-field lines are straight lines, but converging towards a focus point, and thus it is a convergent inhomogeneous (gradient) field. The elementary dipoles of the dielectric are attracted towards the greater E-field intensity, and they represent the 'convergent-field effect' (CFE) forces, which are basically dielectrophoretic forces (*Comment: exactly this issue, i.e. the E-field gradient, was considered in the report given by me at a congress held in Saint-Petersburg in 1998. The report is published in a book titled "Fundamental Problems of Natural Sciences", vol I, p. 195-200, 1999, Saint-Petersburg, Russian Academy of Sciences Publishers, SpbSU. A.V. Frolov*).

The first attempt to mathematically analyze these forces was presented on the page [fullcylsph.htm](#), but the results are not in consonance with the preliminary measurement results obtained so far. This deviation indicates that the dielectrophoretic forces within the dielectric can not be calculated simply by using the Coulomb's law for each molecule and integrate their cumulative effect. Since the E-field intensity can not be lower than what follows from the line integral along a specific E-field line calculated with the formula (1), it is obvious that the electrostatic forces acting on the charges of the elementary dipoles of the dielectric will be less than predicted by the Coulomb's law. The question of exactly how much less, and why is the Coulomb's law not valid in this case, should be answered after further research is done, and measurements performed.

The second form how these dielectrophoretic forces can manifest is shown on *fig. 5b.* on the page [dieltutor.htm](#). In this case the E-field lines are not straight lines but they represent arcs and curved lines. Since in such cases the charges of the elementary dipoles are not attracted in exactly the opposite direction, they will be not attracted only towards the greater E-field intensity, but also towards the concave side (or focus point) of the curved E-field lines. Since in most cases such arced E-field structure appears around the edges of capacitors they have got the name of 'edge effect' (EE) forces to be differentiated from the CFE forces. Its working principle and the related basic calculations were presented on the tutorial page [dielforce.htm](#) specifically illustrated on *fig. 12* and *fig. 13*. A mathematical analysis of these EE forces has been presented on the page [dielphpump.htm](#), and their utilization to produce free energy is suggested.

This type of dielectrophoretic force is present in the dielectric of the T capacitor since the shape of the E-field lines are arced, and the resultant EE forces will point towards the center of the semicircles in upward direction. This is the new force component not explained by Brown and Frolov, although it is stronger than the originally declared EP forces.

The E-field shape and forces on a “thin” T capacitor

When the layer of dielectric below the electrodes is not enough thick to include almost all E-field lines and therefore a significant E-field exists even below the dielectric layer then we get approximately the following E-field distribution:

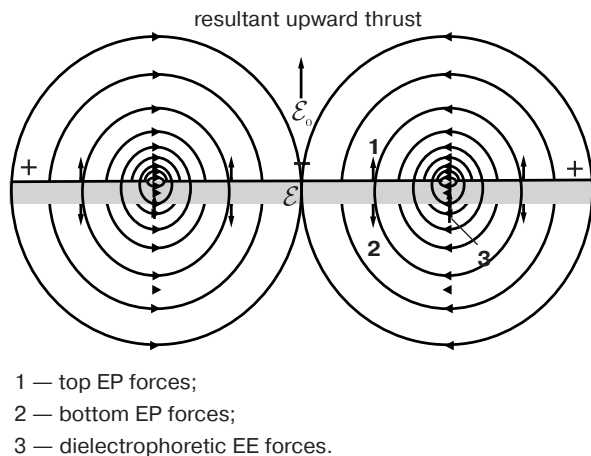

Fig. 4. The E-field distribution and forces on a thin T capacitor

As the above figure shows the E-field intensity within the dielectric in this case is really less than below the dielectric or above the electrodes. At first sight this would suggest that the EP forces below the electrodes are indeed smaller than above the plates. Although the EP forces on the boundary layer of the electrodes and dielectric is less than in the case of a thick T capacitor, the strong E-field below the dielectric is still present and it will increase the downward force component. On the boundary layer between the dielectric and air there will be non-compensated bound charges that will create an intense E-field, similar to that above the electrodes. Thus there will be additional, fairly strong EP forces upon the bottom surface of the dielectric pulling the thruster downward. Therefore the desired strong asymmetry of the EP forces is not achieved in this case either, when the E-field intensity is less in the dielectric than above the electrodes.

The source of the resultant upward thrust observed in experiments is again the edge-effect (EE) dielectrophoretic forces as in the case of the thick T capacitor.

There are two more force components present in the T capacitor. One is the force developed by the ionized air, but if the edges of the electrodes are well insulated it can be minimized. Even if these forces were present they would produce a downward force, and could not be the source of the observed upward thrust.

The second additional force component is the *Biefeld-Brown effect* that produces a unidirectional reactionless force from the negative electrode towards the positive electrode, independently of the shape or intensity of the E-field and electrodes. The effect of this force component can be also neglected in the T capacitor, because it would represent a horizontal force component that does not contribute to the vertical thrust. The intensity of this force is also much less than the other components (at least for the voltages applied so far) and it is neutralized by the stacked T capacitor elements placed side by side in one plane with alternating positive and negative (or grounded) plates.

Using the presented principle for the optimization and development of practical E-field thrusters

The guidelines for the development of practical E-field thrusters can be understood if one realizes the main problem of inefficiency. The main problem is that different force components fight against each other and diminish the resultant unidirectional thrust. The art of developing efficient E-field thrusters is to amplify the strongest force components pointing in the same direction, and weaken the unwanted force component opposing these forces. In order to maintain high efficiency it is also important to prevent current leakage through ionization or caused by insufficient insulating properties of some dielectrics.

Summary:

- *The basic concept of the necessity of asymmetrical E-fields for the creation of a unidirectional reactionless thrust in E-field thrusters has been declared by T. T. Brown.*
- *The original explanation of the T capacitor's principle by Alexander Frolov is to achieve lower electrostatic pressure force on the bottom of the electrodes than above the plates by placing a sheet of dielectric below the electrodes (Comment: It is not exactly so. A.V. Frolov).*
- *It has been demonstrated that there is no electric field asymmetry between the top and bottom region of the thruster with a thick dielectric, which is contradicting the original expectations. Even in the case of T capacitors with relatively thin dielectric layer the E-field intensity is weaker only within the dielectric, but a strong E-field is still present on the bottom surface of the dielectric layer producing strong unwanted downward forces.*
- *It has been demonstrated that the EP forces below the electrodes are not smaller than those above the plates, and in the case of the thick T capacitor it is even greater than the upward EP forces. Thus the EP forces can not be the source of the observed resultant upward thrust as expected by the original theory.*
- *A new principle of producing unidirectional reactionless thrust has been presented. The thrust of this principle is created by the dielectrophoretic forces, that was not recognized and explained previously as the source of reactionless thrust in E-field thrusters. Two main variants of these dielectrophoretic forces were shown: the 'convergent field-effect' (CFE) forces and the 'edge-effect' (EE) forces.*
- *It has been demonstrated that the EE forces create the observed upward resultant thrust in the T capacitor and not the originally declared EP forces acting upon the uncompensated charges.*
- *The guidelines for the development of practical E-field thrusters were presented that directly follow from the presented real working principle of the T capacitor thruster.*

RELEVANT LINKS:

- <http://www.soteria.com/brown/docs/index.htm>
- <http://www.faraday.ru/t-cap.htm>
- <http://www.faraday.ru/pot.htm>
- <http://www.faraday.ru/gradient.html>
- <http://www.faraday.ru/gravityconcept.htm>
- <http://alexfrolov.narod.ru/plan.htm>
- <http://www.geocities.com/a2509/electrogravitics.htm>

Eagle-Research

Energy Solution since 1984

**A research Organization that
develops & Distributes
Practical Energy-Saving
Methods and Devices**

4 Energy Way, POBox 118
Porthill, Idaho 83853 USA

fax 1-250-492-7480

**Technical questions to:
wiseman@eagle-research.com**

Infinite Energy

magazine

- * Cold fusion
- * New Energy
- * New science and technology

Subscription 6 issues per year

\$49.95 foreign

single sample copy

\$10.00 foreign

POBox 2816-FV

Concord, NH 03302-2816 USA

Phone 603-228-4516, fax 603-224-5975

<http://www.infinite-energy.com>

A Precession Free Energy Generator

V.I. BOGOMOLOV, Russia
tel: + 7 812 271 94 08

Our magazine has recently drawn our readers' attention to the fact that any potential field represents a possible source of free energy [1]. Several practical implementations have also been proposed. As reported in "New Energy Technologies" magazine, several inventors are making use of the Physical Effect of Precession (PEP) in order to create vehicles that do not need to have a fulcrum to move and also to generate free energy.

In the present article, on the basis of experiments, carried out at the Faraday Lab Ltd. (experiments with a speed inertia governor have been covered in previous issues of the magazine [2]), and by describing the MBG free energy generator, an effort is made to give a concrete example of how inventors can use the Physical Effect of Precession to create devices, aimed at utilizing of any conservative natural forces of potential fields. These are gravitational, electrostatic and magnetic fields, Coulomb forces, Van der Waals forces of structural unity of a substance (of a spring, for example) and others.

The purpose of publishing this article is to find business partners and investors, whose cooperation with the author and the laboratory would be aimed at commercialization of this new innovation product and at license transfer. This cooperation will also allow the inventor to complete his scientific research and to apply for patents.

Preface

The kinematic scheme of the mechanism of a gyroscope with 3 degrees of freedom of flywheel rotation makes it possible to transform a mechanical system comprising substance elements and physical vacuum elements (aether) into a "flywheel in the artificial potential field of inertia centrifugal force". This results in an environmental resonant energy interchange, leading to the creation of a system of precession rotation by means of the structure of substance elements of the gyroscope construction. This allows us to utilize environmental free energy, in particular, to pick up available energy by means of a load.

Description of experiments

The physical effect of precession is one of many tools granted to mankind by Nature that allows the tapping of free energy. It is a key to inexhaustible supplies of conservative forces of potential fields. Traditional physicists have been concealing this fact for many years. In traditional reference books intended for students and engineers you will not find any conclusions implying that the power on the shaft of the moment of a gyroscope's precession forces represents free energy, which appears due to the action of such external forces, applied to the rotor axis, as, for example, the gravitational energy of the weight force of the displaced center of gravity of a rotor. This power, however, does not appear due to the transformation of the electrical energy, with which the gyroscope's rotor is supplied, into mechanical energy. A manual published in 1964 [3] gives a short description of the theory of gyroscopes, unveiling secrets only to a limited number of people aware of the mysteries of the PEP. This book is intended for aviation engineers-to-be who are only about to study drafts and designs of aviation gyroscopes.

Proceeding from long-term experience of practical verification of mathematical theories, D.S. Pelper comes to the following conclusion: "The nutational gyroscope motion represents an inertial motion... The surplus inertial moment, which is also called the product of inertia forces in theoretical mechanics, tends to align the gyroscope's rotor axis with the axis of the cardan's external case, since the balance is broken during the nutation. In the process of precession, a dynamic balance between the external moment of force and the gyroscopic moment, equaling the product of inertia forces, is created... The gyroscopic moment represents the inertial resistance, shown by the gyroscope when it resists to the applied external moment of force... *As follows from the equation of the precession law, the precession motion of the gyroscope's rotor axis, equaling it, is determined by the external moment of force, acting on the gyroscope... The precession represents an inertialess motion*". Let us make our own conclusion proceeding from this thought: precession is a specific instrument that allows us to use the **energy of external forces**, applied to a gyroscope's rotor due to the creation of a centrifugal **inertia force** moment, which appears due to the Physical Effect of Precession.

In Pelper's book, formulas describing laws of motion of the gyroscope based on examples of mechanical models are deduced. In these experiments, a balance-weight is used as an external force, applied to the rotor shaft. This means that the energy of the gravitational field is used, the capacity of which, in the form of precession moment of force, is being utilized for free! The question arises as to why the author does not come to the next and most evident conclusion. It is clear that in order to receive power from

the axle of a precessing gyroscope, we have to accumulate the electrical energy in the form of the kinetic energy of the flywheel rotation, and then simply replace its small friction losses for an unlimited period of time, since according to theory, no gyroscope's rotor energy is spent on the generation of power of precession forces.

In order to verify this fact, a simple experiment was carried out. Its purpose was to verify whether any surplus energy was consumed by the gyroscope's motor during the process of utilization of gravitational energy at the precession axle. In order to carry out the present experiment, a scheme suggested by Kl.E. Suorts was used.

Basic physical principles are described in a book by Kl.E. Suorts [4]. The book also contains his interpretation of the gyroscope experiment: "You may create a gyroscope using a bicycle wheel. Hang a front wheel removed from a bicycle by one end of its axle on a lace, as is shown in Fig.1. Lower the other end of the axle so that the wheel is supported by the lace only. An unbalanced moment of forces, overturning the wheel, will be created right away. Gravity force, applied to the center of the wheel and directed vertically, acts on it. The arm of the present force equals the distance from the center of the wheel to the point where the lace is attached.

Now do the same, but this time ask someone to set the wheel in rotation before you start lowering it. The same unbalanced moment of gravity force will act on the wheel, but it will not get overturned. The wheel will remain vertically balanced, while its axle will slowly turn in the horizontal plane around the lace".

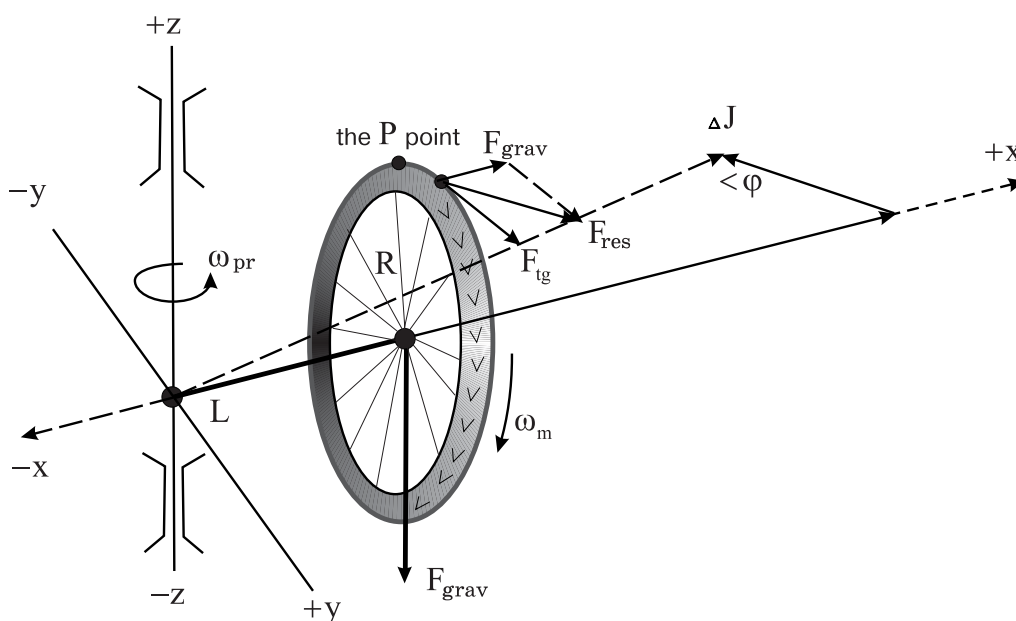

Fig.1

Why does the wheel not overturn and where does the moment of impulse, connected with the wheel center motion along the horizontally oriented circle, come from?

In order to explain the present phenomenon, let us consider what happens with the upper “*P*” point of the wheel. If we look from above, this part of the wheel gets overturned to the right. Consequently, the force acting on the *P* point is also directed to the right. However, the *P* point is rapidly moving forward (when we look down at the wheel). *The overturning force imposes a small impulse on the P point* (the italics are mine; it draws reader’s attention to the source of impulse energy! *V.I. Bogomolov*); the impulse is directed to the right and is vectorially added to the main impulse of the point in question, which is directed forward. The resultant impulse will have a direction that corresponds to the turning of the whole wheel to the right. Instead of getting overturned, the wheel and the plane of its rotation will turn to the right.

Forces and impulse moments are shown in *Fig. 1* by arrows directed along the corresponding axes. In this system, the rotating wheel has the largest impulse momentum, which is directed along the horizontal axis. *The gravity force momentum also lies in the horizontal plane. However, it is situated perpendicular to the wheel axle* (italics and bold print are mine). **Due to this, the moment of gravity force does not decelerate the wheel and does not take away its kinetic rotation energy, which is needed for the action of precession forces moment of the P point!** During each time interval *dt*, the moment of gravity force alters the moment of precession of the *P* point: $\mathbf{M}dt = d\mathbf{J}$. This increment of impulse moment is directed transversely to the main impulse moment of the wheel and *does not change its module. However, the momentum of gravity force changes the direction of the impulse moment of the P point of the wheel.* The axle of the wheel rotates in the horizontal plane, and the rotation continues while the *moment of gravity force is present.* Such motion is called “precession”.

In the experiment according to Suorts’ scheme, the rotor, in the form of a bicycle wheel, was replaced by a cylindrical rotor of an electric motor with a diameter of 10 cm, a speed of rotation of 15,000 rot/min and a weight of 2 kg. The arm of gravitation forces moment amounted to 10 cm. A wire, loaded with a 200 g balance-weight via a block, was wound around the precession axle. This was done in order to pick up the axle’s available output, equaling $N=mgh/t$. In a quiescent state a fixed motor consumed a DC current with a voltage of 25 V and a current intensity of 0.5 A. The power of the current amounted to 12.5 W. The angular velocity of the precession axle amounted to 1 rotation per 5 sec. When the work of

lifting the balance-weight to a height of 1 m was performed and the wire was spooled around the precession axle, the ammeter and voltmeter readings remained stable. The same was observed when the precession axle was hard braked. We also compared the time needed to fully stop the rotation of the fixed electric motor’s rotor without any load and with a load on the precession axle with a balance-weight after the power supply was switched off. In both cases it amounted to 31 min. Furthermore, when the gyroscope’s motor was switched off, the gyroscope performed the work of lifting the balance-weight for 17 minutes. Conclusion: the gyroscope’s motor was not consuming any extra energy during utilization of gravitational energy on the precession axle!

After studying Suorts’ and Pelper’s interpretations and proceeding from the results of our experiment, it becomes clear that the constant of the flywheel’s impulse moment in its basic rotation is easily maintained in the present device, since in order to maintain the inertial flywheel’s rotation, only the rolling friction of the bearings must be overcome. The rolling friction increases linearly with the increase of angular velocity (we also know the designs of magnetic suspensions, air bearings and other devices, the resistance of which is minimal). The increase of the flywheel’s angular velocity, which must be maintained at that level, to obtain the possibility of building up the influence of external forces on the moment axis. *The gravity forces can be replaced by other conservative forces, such as, for example, the backmoving forces of a spring or by the forces acting inside permanent magnets.* In this way we may achieve the generation of free energy, several times exceeding friction losses, by means of picking up the power of precession forces from the gyroscope axle. The electric energy is consumed by the gyroscope only to create favorable conditions for precession. By directing a part of the free energy received in order to replace the energy spent, we will get a “perpetuum mobile of a second kind”.

The essence of the mechanical effect obtained is determined by natural physical phenomena observed in the gyroscope, namely, the interdependence of constants of two moments of rotation impulses — of the flywheel and of the gyroscope’s precession rotation. This effect is also determined by the effect of quantification of the precession impulse moment by the \mathbf{L}/\mathbf{R}^2 parameter value, where \mathbf{L} is the inertia radius of the precessing mass of the flywheel and the action arm of the gravitational force and \mathbf{R} is the inertia radius of the flywheel rotation. In other words, the intensity of the influence of gravitation (weight) on the arm with a change in this parameter is constantly limited by the extreme of the constant of quantification of the flywheel’s impulse

moment, in which a surplus inertial moment (the product of inertia) is opposed to gravity, and in which the vertical plane of the flywheel rotation is preserved. In this case the flywheel does not fall.

Explanation of the essence of the process of obtaining free energy in a precession generator

The explanation of the process of obtaining free energy in a precession generator is possible only on the basis of a *new physical paradigm* [5], postulating that substance elements are no more than vortices of the aether medium, which maintain energy interchange balance with the environment. The aether medium (a physical vacuum) may structure itself and form its elements as mechanical systems (vortices, and packets of standing waves) according to a universal kinematic scheme that B.P. Ivanov [6] called “the organizational form of matter”. “New Energy Technologies” magazine has previously informed its readers about an experiment of obtaining free energy by using natural features of potential fields of inertial centrifugal forces [2]. All organizational forms of matter possess features of a quantum-mechanical system: quantification of density of the kinetic energy of aether’s elements motion by volume and mass density, quantification of the impulse moment on the radius of curvature of the vortex’s trajectory and on the radius of inertia of a localized mass of aether’s elements. Perpetual motion, energy interchange and its transformation in the aether medium are taken for granted by the new paradigm and are described by a universal action algorithm called “the Law of Interdependence of Processes” [7]. This means that generation of free energy followed by its utilization in technical devices seems to be real. *Quantification of the density of the kinetic energy of aether’s elements motion by volume in the organizational form of matter, forming a potential gradient, can be used to describe mechanisms of creation of forces and output power of all potential fields*, namely gravitational, electrical and magnetic fields. It can be used to describe the photo-effect, Archimedes’ lift forces, and also to describe the formation of the kinetic moment of centrifugal forces in the potential field of inertial centrifugal forces.

The kinematic scheme of the gyroscope design is created according to the Laws of the Organizational Form of Matter and its algorithm of the Law of Interdependence of Processes. In this scheme, the correlation of the quantized precession impulse moment and the quantized flywheel impulse moment are ensured by the L/R^2 correlation. This complies with conclusions, following from B.P. Ivanov’s theory: “A standing wave process divides the volume of the proper sphere of the organizational form of matter both inside and outside

its nucleus, into “envelopes” comprising equal masses of matter. For this reason, and as a consequence of the decrease in density of matter of a physical field, radii of envelopes increase as squares of a natural sequence” [5, page 272]. The consideration of regular kinematic-geometric parameters of a gyroscope’s construction allows utilizing free energy according to the Law of Interdependence of Processes. This utilization implies the picking-up of the available output of the moment of precession forces on the gyroscope axis. The design of the gyroscope also allows using the energy of structural unity of the substance of which the gyroscope is made. This implies that the work is performed by the structure of substance elements, while the potential of recovery elastic forces (electrostatic Coulomb’s forces acting inside the lattice and Van Der Waals forces), which are constantly resupplied by the energy from the aether medium, are spent.

The Marinov–Bogomolov Generator (MBG)

The discovery of the possibility of obtaining free energy during the formation of the kinetic moment of centrifugal forces in the potential field of centrifugal inertial forces, made by the author, enabled him to create a working prototype. The invention was first mentioned in the article titled “Russian Inventor Needs Technology Transfer”, which was published in the “Peterburgskij Analitik” (Saint-Petersburg Analyst) analytical bulletin (№7 of 07.09.99). In that article, I described a method for obtaining 3 kW of output power on the shaft of a prototype, set in rotation by an 8 W electric motor. The experiment was verified in August of 1999 by a commission consisting of representatives of the University of Aerospace Instrument-Making Industry and of the before-mentioned magazine. The commission was headed by Professor M.S. Katkov.

The present device for the obtaining of free energy was named the “Marinov–Bogomolov Generator” (MBG) in memory of Stephan Marinov, a Bulgarian scientist and inventor [8].

In 1998, the idea came to my mind of using a system of ultrasonic resonators in technical devices in order to obtain non-compensated centrifugal inertial forces of wave impulses in the mass of the substance they are made of. However, I decided to build a simpler and cheaper mechanical model using the spring pendulums that are used in laboratory research. This model was intended to simplify calculations concerned with ultrasonic resonator pendulums.

In June of 1997, a temporary research group was created, consisting of seven members of the Laborato-

ry for Applied Tasks of the Center for Fundamental Research, founded by Dr. V.Ya.Brill at the Saint-Petersburg Mining Institute. A contract was signed with the "TEST Separate Design Office" Company, headed by B.P.Kuzmin, for the construction of an experimental installation. In March of 1998, during the testing of the installation, stable results were achieved: the free energy, generated by the installation and the power of its output exceeded the power spent on resonance initiation by a factor of two.

Later, a second contract with the "TEST" Company was signed, proposing a modernization of the model that had been created to bring it up to production standards using an investor's funds. However, the financing was stopped.

The principal scheme of the MBG generator is based on Marinov's [8] scheme of the "Buller-Marinov Generator", and uses in part the operating principle of a well-known mechanism – the "centrifugal vibrator" - and the physical effect of precession. Symmetrical and simultaneous rotation of masses of disbalances, taking place in this design, results in an oscillating spatial motion of the entire system (case). The same effect may be observed in related mechanisms, namely in Tolchin's and Savelkaev's inertoids.

The difference between the proposed scheme (Fig.1) and the scheme of a centrifugal vibrator lies in the idea that the rotary motion of disbalancing flywheels was replaced by the oscillating motion of balancing pendulums. The kinematic scheme of our installation bears resemblance to the before-mentioned Suorts' scheme, the main difference being that it is created as a system of balancing pendulums. The first balancing pendulum is a spring-backed swinging lever (1) mounted on a solid base, on which a bob (2) oscillates with its own resonant frequency on the power-picking axle (3). The second balancing pendulum is a subsystem, playing the role of a weight (2) for the spring-backed swinging lever. A 50-kilo weight (5) swings on the lever (4) of the pendulum with its own resonant frequency, which equals the frequency of the first one, but with a phase shift totaling a quarter of a period.

The second pendulum swings in planes that are situated orthogonally to the swing of the first pendulum. Due to this, the impulse of inertial forces transmitted to the first pen-

dulum, does not dampen down the proper natural resonant oscillation of the second pendulum. If masses interact at a right angle, (during hard or soft concussion of the masses), no speed exchange takes place. However, *a peculiar feature is present in our device's kinematic scheme: the resonant supply of energy directed from the first pendulum to the second, takes place indirectly, by means of initiated inertial centrifugal forces and the energy of the deformed structure of physical vacuum substance elements (of aether).* As a result, the inertial oscillating spatial movement of the whole system of masses transmitted to the swing shaft (3) causes an increase in the device's capacity. Curved trajectories of the weights' masses create an artificial system, which is **a potential field of inertial centrifugal forces of physical vacuum's medium (aether) that performs the work of spatial handling of pendulums's weights. The work performed by the spring elastic forces represents another source of free energy.** These forces, in their turn, also receive energy from the medium of the physical vacuum during the process of constant substance-medium energy exchange, providing for the structural unity of the material that the springs are made of, within the limits of its strength (i.e. until the moment when the steel will become "fatigued").

The interaction of the two pendulums' weights masses in the proposed scheme represents the consequence of the *physical effect of precession.*

The installation turned out to be heavy, weighing more than 100 kilos, but quite cheap: the balancing

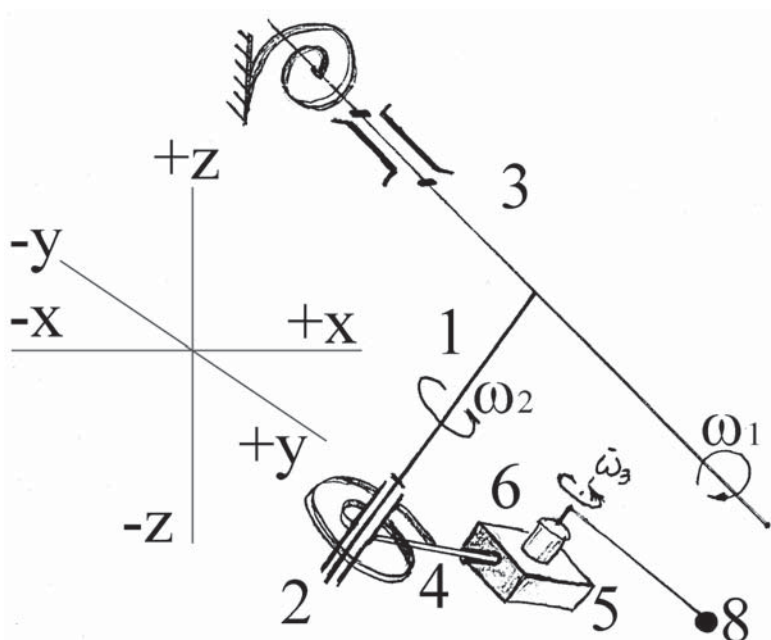

Fig. 2

swing of the resonator, for example, was made out of the torsion suspension of an old automobile's shock-absorber. The second balancing pendulum also represents a self-oscillating system. Its oscillations are initiated and maintained (in resonance) by means of a centrifugal vibrator that represents an electric motor with a "rider" – type reducer (8 W, 27 V, 6000 rot/min.) (6), which rotates a lever (7) with a 70-gram weight (8) on its shaft. The angular velocity of rotation, amounting to 1 Hz, equals the frequency of oscillations of the second pendulum.

When the frequency of rotation of the balance-weight (8) amounts to about 1 Hz, both pendulums start to resound and oscillate with a maximum amplitude just two seconds after the electric motor has been switched on. This motion on the output of the swing shaft is characterized by the following indices: rotation oscillation at an angle of 7–10 degrees with a frequency of about 1 Hz. **The output capacity, which was evaluated by means of braking, amounted to about 3 kW.**

Since a 50-kilo weight (5) reaches the impulse power of 3 kW in **2 sec** using the power of the initiation device equaling 8 W, it is evident, that the present gain in power cannot be obtained by means of accumulating the energy of the electric motor in the mechanism. It would take more than **6 minutes** to accumulate such an amount of energy.

The principles used in the design of the prototype of the GMB generator, have already been implemented by the author in two other devices intended for mass production. The first device, named "Kamer-ton" (Tuning Fork), is intended for heating farmers' greenhouses and townspeople's country houses. It has been designed to be cheap and simple in production. The scheme of the device is not given in this article since it is the "know-how" of the author.

Another device, called the "UZV Modul-Generator" (Ultrasonic Generating Module), is a universal electric energy generator. Depending on the number of modules in a block, this device may be used to supply energy to any electrical consumers (domestic electric appliances, electric vehicles, and factory equipment as well).

Proceeding from the scheme shown above, by using piezocrystals for the generation of EMF (1) and an ultrasonic resonator (oscillator) made of a block comprising a number of nickel plates (2), an effective and compact version of the GMB generator can be constructed (Fig. 3). A solenoid, receiving energy from an AC generator, (3) will initiate the resonator's natural oscillations (2) (the magnetostric-

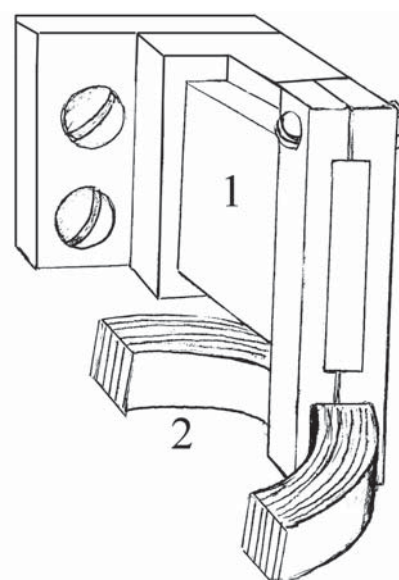

Fig. 3

tive effect), gradually matching the resonance frequency according to the principle of feedback in self-oscillating systems. A more detailed description is not available since it is also the "know-how" of the author.

REFERENCES:

1. A.V. Frolov, "Free Energy", *New Energy Technologies*, №1, 2003
2. V.I. Bogomolov, "Bogomolov's Generator", "An Experiment of Using Free Energy", *New Energy Technologies*, №№4, 5–6, 2003
3. S.P. Pelper, "Gyroscopic Devices and Autopilots", Moscow, Nauka Publishers, 1964, pages 32–33
4. K.I.E. Suorts, "An Extraordinary Physics of Common Phenomena", Moscow, Nauka Publishers, 1986, pages 174–175
5. V.I. Bogomolov "A Matreshka-type Paradigm of World's Physical Structure". Schemes for utilization of energy of conservative fields, A collection of articles, Saint-Petersburg, 2002.
6. B.P. Ivanov "A Physical Model of the Universe" – Saint-Petersburg, Politekhnik Publishers, 2000
7. A.P. Smirnov "Reality Physics", Collection of articles "The Principle of Order", A.P. Smirnov, I.V. Prohortsev, Saint-Petersburg, PIK Publishers, 2002.
8. S. Marinov "Using of Inertial Forces For Generation of Free Energy", A collection of articles "Problems of Space, Time and Gravity", A collection of articles of the IVth International Conference held on 16–21 September, 1996, Saint-Petersburg, Politekhnik Publishers, 1997.

On The Way to A New Astronautics

A.V. PERFILIEV, Russia
Enthusiastov Str., 74/2, ap. 43
111123, Moscow

About the author: A.V. Perfiliev graduated the Department of Spacecraft Designing of Moscow Aviation Institute (MAI). He worked in the RDE of Applied Electrodynamics (MAI), then – in the State Space Research and Production Complex named for M.V.Khrunichev, participating in the project for developing the International Space Station.

On the background of a rapid development of such fields of knowledge as computer science and genetics the absence of breakthroughs in space technologies became too evident.

The aerospace industry stagnation

A resolution on the usage of a modernized “Soiuz” carrier-rocket as the main medium-class carrier-rocket at the Kourou Space Centre has been recently passed. Meanwhile, this rocket represents a modification of the R-7 rocket by means of which the first artificial satellite was launched forty-seven years ago. Add three years that were needed to design the rocket and you will get fifty years, upon expiration of which this construction starts the next (as it is difficult to call it “new”) epoch in modern astronautics. It is fairly hard to imagine that Wright’s airplane could have been in operation until the 1960-s.

Descent modules with American mars-rovers and the European “Beagle-2” module used large air bags for soft-landing on the surface of Mars. This meth-

od was first used in the construction of a Soviet automatic interplanetary “Luna-9” (“Moon-9”) station that was the first to soft-land on the Moon surface. At that time it was a measure of necessity since there was no time left for the adjustment of the landing system by installing vectoring thrusters. Now it may be considered as a regress since though air-bags can provide for weight and economic efficiency, they are not as reliable as it may seem. This was confirmed by the failure landing of the “Beagle-2” landing module and the problems, which occurred when the “Spirit” mars-rover failed to descend from the platform because of one of the air-bags not being totally empty.

The principle of reactive motion was used in the ancient China as far back as four thousand years ago.

Tzyolkovsky and Goddard, the pioneers of astronautics, started their research by studying reactionless propulsion systems. Tzyolkovsky analysed a centrifugal machine while Goddard tried to make use of electrodynamic installations. However, a quick solution of the problem was not found and the before-mentioned and slightly improved technology was used during the mission to the Moon.

It took great effort of a super-power to accomplish missions to the Moon, while a mission to Mars still remains to be technically and economically insoluble problem. A flight to other planetary systems by using reactive thrusters, be it nuclear or electro-jet, seems to be as unreal as a journey to the Moon by means of a cannon.

New physical principles

It is not very often that fully studied phenomena are technically imple-

mented. The initial stage of the development of aviation was completed before aerodynamics appeared as a field of science. At that time, copying a natural object, a bird wing, was the main direction of research. By the way, the principle of reactive propulsion is also used by living organisms, in particular by the octopus. It seems that there are no more natural analogs left to copy new principles of creating a thrust. But it is so only at first glance. Mankind has long since been aware of permanent magnets that effectively interact with each other. What we need to do is to make them interact with the physical vacuum. In order to accomplish this task we need to disturb the physical vacuum by means of a magnetic build-up at resonant frequencies. It is possible that this very principle is used in the Roshin — Godin's generator.

It is strange that the scientific world left this experiment unnoticed. If weightlessness of the installation amounting to 120 kg is a traction effort, the installation could be used right now as a medium-thrust engine for space flights along interplanetary trajectories since 120 kg of thrust is much more than electro-jet engines can provide. The installation, what is more, is partially or entirely used as a power source. Moreover, it does not use any working medium for creating thrust. The use of principle of creation of both thrust and energy inside a single installation, which have already been realized in liquid-fuel rocket engines, is to be wished.

If we proceed from the idea that the physical vacuum resists to objects moving with acceleration, thus causing relativistic effects, we need to built a spacecraft surrounded by a lens consisting of a physical vacuum separating the inner physical vacuum (inside the spacecraft) from the external one for accomplishing space flights for interplanetary distances. The alternative is to break the structure of the physical vacuum before a flying spacecraft. In both cases the physical vacuum inside the spacecraft will remain motionless, which will cause zero gravity. At the same time, a small and accelerated stream of the physical vacuum could be let pass through the spacecraft in order to create the Earth gravity. It will allow us to maneuver and to accelerate without exposing the crew to gravity loads. The flow of external physical vacuum around the spacecraft will allow increasing the flight speed without any limits. Let us draw an analogy from aviation: during the flight of a biplane air moves between its wings, thus increasing the biplane's resistance with the speed increase. A monoplane with arrow-type wings is

flown around as a single object; that is why it may break the sonic barrier relatively easy. The speed of sound in air is limited by the "M" value (the speed of sound). At the same time it exceeds the "M" value inside a flying supersonic aircraft relative to a motionless observer. A material object may exceed the speed of light when traveling inside a physical vacuum lens, flown over by the external environment. One of the most interesting by-effects accompanying the flight will be full invisibility of a spacecraft if it is moving towards the observer or from him and blurring of contours at other angles of view.

Practice is the criteria of truth

At present moment it is to be wished that experiments with the Roshin-Godin generator are resumed and some alterations are made in its construction.

First, the axis of rotation should be placed horizontally in order to find out whether a change in mass is caused by the creation of thrust or whether the mass changes independently. This means that depending on the direction of rotation the installation may create an accelerated stream of physical vacuum; it may also thicken or reduce the physical vacuum. In the latter case the change in density of the physical vacuum would decrease or increase the influence of the Earth's gravity field (as it might represent the physical vacuum density gradient) on the weight of the installation.

Second, magnetic inlays on the rotor's rolls and on the stator should be removed and replaced by driving electric motors installed on axes of all rolls. Though the effect of self-acceleration will disappear, we shall be able to find a precise resonant ratio of rotation speed of the rolls to the speed of rotation of the rotor as a whole. And only after this magnetic inlays must be installed with optimal spacing.

Third, the role played by coverings of magnetic elements made of copper should be found out. In order to perform this task, a number of experiments should be carried out without any coverings.

Finally, the creation of multi-row installations is also possible. It is reasonable that it will take great expenses. But they cannot be compared with multi-billion sums of money spent on carrying out manned space missions to Mars and to the Moon that the USA, the EU and China are planning to realize in parallel. It is worth mentioning that these missions are mainly politically biased.

An Energy Converter

The author of the device: **BEREKELEA A.N.**,
Aberechelea@UFMoldova.com
tel. +373 94 59826

A converter of the magnetic field energy into the electric energy

Our research team has practically finished the work on creating a unique technology that will enable mankind to get **mechanical energy**, which is the cheapest today and which, as it seems, will remain the cheapest in the near future.

This technology is based on a whole array of principles and methods of converting external energy into mechanical energy, which implies that other types of energy can be generated as well – including electrical, chemical, heat energy etc.

Members of our research team have got about 150 patents in the fields of research relating to those described in the article.

In the theoretical part of the work, a logical basis has been laid and the main principles of generating mechanical, electric and other types of energy have been worked out. Technical solutions based on these principles are **ready to be patented**.

In the practical part of the work, one of the main principles formulated is realized in an operating device. The device is a cold generating energy converter. This device is a **prototype** (hereafter referred to as “the converter”) with a wattage of 5 kW and a weight of less than 25 kg. It comprises three interconnected functional blocks. The converter uses two or three external energy sources, including the energy of the gravity field. The given wattage of the converter is selected for the sake of performing research tasks and for the development of principles of high wattage installation construction. Power equipment created on the basis of this prototype is quite manufacturable, failsafe and stable in operation, having small dimensions and comprising a minimal number of components – three

(equaling the number of functional blocks).

Capital, operational and consumption outlays per 1 kW of the set power are minimal, due to the absence of thermo-technical equipment and of traditional thermodynamic process mechanisms. As a result, the payback period of a converter with a wattage of 300 kW, according to our preliminary estimations, will amount to 4 to 6 months. This means that the generation of almost free energy would be possible in less than a year.

According to our estimations, construction of our devices leads to a reduction in the payback period due to the wattage increase. We don't see any technical limitations in the production of cold generating energy converters of practically unlimited power (right up to the reaching of APP power unit wattage).

The prime cost of 1 kW of energy, including the electric energy, generated according to this technology, is a hundred times lower than the prime cost of the energy generated by hydro, atomic and heat power plants.

This technology makes possible the production of domestic, industrial or electric power installations used for the generation of AC/DC current of the necessary voltage and wattage.

Because the proposed technology does not imply the use of either nuclear or fossil fuel in the working cycle and does not generate any excessive noise, it is environmentally safe.

It is technically possible to produce devices of any power, built according to this technology, and to use them in any region of the Earth, which will allow building power-consuming facilities without the need to have power stations or high-voltage power lines in the vicinity. The technology will also allow make it possible to abandon the need to use expensive means of energy transformation and its delivery to the destination point, thus reducing enormous expenses.

The converter can be functionally used, not only as a power unit. After the installation of additional devices, it can successfully act as a propelling unit on ships, locomotives, automobiles etc.

New Energy Technologies CD

All back issues of 2001–2003

We would like to suggest you to have a look at the list of articles that were published in our magazine during past two years. You may order a CD, containing PDF-files of all these issues (covers included and are in JPEG format).

2001, №1 (1)

- An Experimental Investigation of the Physical Effects In a Dynamic Magnetic System. V.V. Roschin and S.M. Godin
- Torsion Technologies Are XXI Age Technologies. Acad. Anatoly E. Akimov
- On New Energy and Political Authority, Alexander V. Frolov
- Calculation on the Effect of Many-Cavity Structures by Prof. Valery F. Zolotariov
- Quasi-Superconductive Technology for Electric Power Transmission. Prof. Dmitry S. Strebkov
- Water is the Basis of the Future Energetics. Prof. Phillip M. Kanarev
- Over-unity Patent of 1877 by Pavel Yablotchkov
- The Fundamentals of the New Principles of Motion, P. Sherbak
- A Design of an Engine For Free-Space Flights Based On the Pondemotor Effect. Acad. Gennady F. Ignatyev.
- Experimental Gravitonics. Spartak M. Poliakov and Oleg S. Poliakov
- The Physical System of Artificial Biofield. Dr. Alexander M. Mishin
- Experiments on Change of the Direction and the Rate of Time. Dr. Vadim A. Chernobrov
- On Some Properties of Physical Time and Space. Prof. Dr. Albert I. Veinik
- Causal Mechanics. A review about a research by Prof. Nickolay A. Kozyrev
- Spin (axion) Field Generator, Alexander Shpilman
- On the Eve of the Sixth Revolution in Physics, Dr. Atsukovsky

2001, №2 (2)

- Kozyrev-Dirac Magnet-Monopole Emanation. Dr. Ivan M. Shakhparonov.
- The Hydro-Magnetic Dynamo by Acad. Oleg Gritskevitch
- Testing of a Small Prototype to Investigate the Searl's Effect, S. M. Godin and V.V. Roshin
- Theoretical Basis of the Searl's Effect, by Dr. Rykov
- Hydrogen - helium Energy on the Base of Laminated Silicates and Tectosilicates, Dr. Oleg M. Kalinin, Dr. Harmut Mueller, Surina K.S.
- A New Concept of Physical World, Dr. Nikolaev.
- The Main Principle of Etherodynamics, Dr. Mishin
- New Experimental Data from Dr. Mishin on the Ether and Anti-gravity Effects. The Discovery of The Center of The Universe.
- Research on the Capacitance Converter, transforming the Environmental Heat into Electricity, N.E.Zaev.
- Longitudinal Waves in Vacuum: Formation and Research. Dr. Kirill P. Butusov.
- Work, Alexander V. Frolov
- Reactionless Propulsion and Active Force, Alexander V. Frolov
- Rythmodynamics of Amplitudeless fields, Dr. Yury N. Ivanov
- The DNA molecule and Four-dimensional Holography, Alexander V. Frolov
- Gravity and Aether, I.Hayrullin.

2001, №3 (3)

- Time is a Mystery of the Universe, Dr. Lavrenty S. Shikhobalov, St.Petersburg, Russia
- Experiments With a Manned Time Machine. Dr. Vadim Chernobrov, Moscow, Russia
- Time is a Physical Substance, Dr. Kirill P. Butusov, St.Petersburg, Russia
- Experimenting With Time, Prof. Velimir Abramovich, "Time Institute", Rotterdam, Holland
- Practical Application of the Time Rate Control (TRC) Theory. Alexander V. Frolov, Russia

- Irving Langmuir and the Atomic Hydrogen. Dr. Nicholas Moller, Greece
- Hydrogen Energy. Studennikov V.V., Kudymov G.I, Russia
- On Strange Effects Related to Rotating Magnetic Systems. M. Pitkanen, Finland
- Experiments with Transdimensional Lifters. Jean-Louis Nau-din, France
- On the Great Constant 137.036. Dr. Anatoly Rykov, Russia
- Inertia Propulsion Drives. Boris D. Shukalov, Russia
- The Technical Design of the "Silver Cup" Antigravitational Spacecraft, Eugeny Kovalyov, Latvia
- Gravity-inertial Mass. J.A. Asanbaeva, Republic Bashkiria
- Propulsion due to the Relativity Effect of the Inertia Force. Takuya Ishizaka, Japan
- Physical Properties of Axion Fields. Influence of an Axion Field on the Hardness of the Pearlitic Cast Iron. Alexander Shpilman, Kazakhstan.
- On the Significance of the Conical Shape of the Rotor of Clem's Generator. Alexander V. Frolov, Russia
- On History of the Cold Nuclear Fusion in Russia in 1960s. Review, Alexander V. Frolov, Russia

2002, №1 (4)

- On the Possibilities of Vortex Energy. News About Experiments by Acad. Gritskevitch O.V. and Lisniak S.A., Vladivostok, Russia.
- Tesla, "Time Control" and other aspects of Tesla's research, Prof. Velimir Abramovich, Rotterdam.
- Future Energy Technologies, Dr. Thomas Valone, Washington, USA.
- On the Question of Work Performed by an Electrostatic Field, Alexander V. Frolov
- On General Nature of Forces and New Methods of producing propulsion force by Dr. Eugene Sorocodum, Moscow, Russia.
- The Antigravitational Wing, Ponomarev D.V. and Shibeko R.V., Komsomolsk-on-Amur, Russia.
- The Radio-telescope in Pulkovo Receives Signals Coming From the Center of the Universe, Dr. Alexandra A. Shpilnaya and Dr. Alexander M. Mishin, St.Petersburg, Russia.
- The Inertialess Motion and Antigravity Are No More Secrets, Dr. Anatoly Rykov, Moscow, Russia.
- Inductive Conversion of Heat Energy to Electrical Energy, Experiments With Magnetic Materials Aimed At Getting Free Electric Energy From Magnetic Materials by Nikolay E. Zaev, Moscow, Russia.
- Tetra-space Coordinates, Josef Hasslberger, Rome, Italy.
- To the Question of Multipolarity, Alexander V. Frolov, St.Petersburg, Russia.
- Ball Lightning: a Description and Proposals On Experiments, Ivan Tshinarev, Tver, Russia
- The Problem of Electron and Physical Properties of Time Regarding Electronic Technologies of the 21st Century, Prof. Oleinik, Ukraine
- Parametrical Generation of Alternating currents by N.D.Papaleksi, Alexander V.Frolov.
- Gerlovin's Theory of Activation, a review of some experiments on the "structure activation" of matter, Alexander V. Frolov, Russia

2002, №2 (5)

- MEG Over-unity Electromagnetic Transformer by T.E.Bearden and my F-machine, Alexander V. Frolov
- Fuelless Energy, N.E.Zaev.
- Symmetrization of Maxwell-Lorentz Equations. Experimental Methods Of Generating Longitudinal Waves in a Vacuum, Dr. Kirill P. Butusov
- Vortex Heat Generators, Dr. Eugene Sorokodum.
- Experimental Investigations Based on the Model of Electromagnetic Solitary Waves (solitons), Mikhail V. Smelov
- N.Kozyrev's Ideas Today, Dr. Shikhobalov.
- Kozyrev on the Possibility of Decreasing the Mass and Weight of a Body Under the Influence of Active Properties of Time, A review of experiments.
- Longitudinal Thermomagnetic Effect, Dr. Alexander M. Mishin.
- An Introduction to Gravity, Lew Price and Mart Gibson.
- A Physical Model of Experiments Carried Out by E. Podkletnov, V. Roshin and S.Godin, Anatoly Rykov
- Scalar Wars, T.E.Bearden
- The Problem of Electron and Superluminal Signals

- Gravitational Electrolysis

2002, №3 (6)

- Large-Scale Sakharov Condition, David Noever and Christopher Bremner
- Matter As a Resonance Longitudinal Wave Process, Alexander V. Frolov
- The Physical Principles of The Time Machine, Alexander V. Frolov
- The Time Machine Project by Alexander V. Frolov
- Kozyrev-Dirak Radiation, Ivan M. Shakhparonov
- Electrical-Vortex Non-Solenoidal Fields, S. Alemanov
- Physical Mechanism of Low-Energy Nuclear Reactions, V.Oleinik, Yu. Arepjev
- The Evolution of the Lifter Technology, T. Ventura
- Reality and Consciousness in Education and Activity, A.Smirnov
- Old New Energy, Y. Andreev, A. Smirnov
- On the Influence of Time on Matter, A. Belyaeva
- Life Without Diseases and Ageing-Preventive Features of an Electrical Bio-Heater, A. Belyaeva
- A Technical Report on Belyaeva's High-Efficiency Ceramic Heater, Sh. Mavlyandekov
- Fundamental Properties of the Aether, A. Mishin
- The Influence of the Magnetic Blow-Wave Field on Wine Systems, I. Shakhparanov and others
- Nikola Tesla and Instantaneous Electric Communication, V. Korobeynikov
- A Unified Theory of Gravity, I. Kuldoshin
- New Sources of Energy from the Point of View of the Unitary Quantum Theory, L.G. Sapogin, Yu.A. Ryabov, V.V. Graboshnikov
- Antigravity Force and the Antigravity of Matter. Methods of Its Generation, A. K. Gaponov
- A Capacitor, Which Possesses Energy of an Atomic Bomb (Review of Gaponov's research)

2002, №4 (7)

- Gravitonics is the Electronics of the XXI Century, Spartak M. Poliakov, Oleg S. Poliakov
- Experimental Research on a Gravity Propulsion System. Review
- The Beamship Technology: Reconsidering the Discoveries of the beginning of the 20th, Russell Anderson
- Commercial Antigravity, Tim Ventura
- Action Without Reaction. A New Gravidynamic Paradox, Yuri N. Ivanov
- New Possibilities of Vortex Electrical Devices, Stanislav A. Lisnyak
- An Investigation of Electric Energy Transmission Processes in non-Metallic Conducting Channels, D.S. Strebkov, A.I. Nekrasov, S.V. Avraamenko
- Microcosm – Universe - Life, Alexey G. Shlienov, Ernest L. Petrov
- Hypothesis of a Theory of Everything, Jack P. Gibson
- The Charge and Mass of a Photon, Dzabrail Kh. Baziev
- The Homopolar Motor: A True Relativistic Engine, Jorge Guala-Valverde, Pedro Mazzoni, Ricardo Achilles
- Weight Reductions Caused by Bucking-Field Permanent Magnets, William C. Simpson
- Advanced Nuclear Waste Decontamination Technologies, Mark Porringa
- Experimental Investigations of the Change in the Radioactive Isotope Half-Value Period in the Local Volume of Cause-Effect Relations, Igor A. Melnik
- Tilley Electric Vehicle
- The Problem of Time: Force as the Cause of Change in the Course of Time, Valentin P. Oleinik
- Time and its Physical Relationships, Andrew Michrowski
- Time as a Phenomenon of the Expanding Universe, Michael H. Shulman
- Experiments on Thermo-Gravitation. Review
- A Letter to the Editor from Hector D. Perez Torrez

2002, №5 (8)

- Frolov's Asymmetrical Capacitors
- The Electrokinetic Apparatus by T.T.Brown
- A Patent by T.T.Brown
- Nikola Tesla's Later Energy Generator Designs, Oliver Nicholson
- High-Efficiency Electrolysis, Alexander V. Frolov
- New Results of Development and Testing of a Single-Wire Electric Power System, Prof. Dmitry S. Strebkov, Eng. Stanislav V. Avramenko, Dr. Aleksey I. Nekrasov, Eng. Oleg A. Roschin

- Shauberger's Engine? by Eugene Arsenyev
- The De Aquino ELF Gravitational Shield, Tim Ventura
- Ferrites and Generation Of Free Energy by Means of Ferromagnetics, Nikolay E. ZaeV
- Key Concepts for the Conversion and Control of Gravitational Energy, Glenn M. Roberts
- Analysis of the Additional Energy Formation Processes in Vortices and Vortex Heat Generators, Dr. Alexey M. Savchenko
- Kuldoshin's Transformer, Review
- Disappearance of Inertia Force Mechanical Resonances and Free Energy Work, Arkady P. Kuligin
- The F-Machine, Vyacheslav I. Boryak
- The LUTEC Magnet Motor-Generator
- Prof. Korotkov
- Books
- How to Build Electrical Solid-State Over-Unity Devices, William Alek
- The "Time" Seminar Held in Moscow State University
- A Vortex DC Motor
- News
- Valerian Sobolev's Discovery. Review
- Letters from Readers
- Review on the Tilley Electric Car Recharger Promotion, Eugene F. Mallove

2002, №6 (9)

- Some Experimental News, A.V. Frolov
- On the Possibility of Controlling the Course of Time, V.P. Oleinik, Yu.C. Borimsky, Yu.D. Arepjev
- Spontaneous Polarization of some Glasses and Direct Current as an Inexhaustible Energy Source, L.G. Sapogin, Yu.A. Ryabov
- New Fuelless Space Power Engineering, V.D. Dudyshev
- Electrodynamic Explanation of Ball Lightning, S.B. Alemanov
- The Nature of Torsion Fields, V.V. Uvarov
- Matter, Space and Time in the Conception of Aether Field, A.M. Mishin
- Patent Experts Now are Between a Rock and a Hard Place, V. Sharov
- Reidar Finsrud's Perpetual Mobile in Norway, John Pasley
- Physical Quantum Vacuum is a Source of Electromagnetic Energy, P.M. Shalyapin
- What is An Instantaneous Electrical Communication, V.I. Korobeynikov
- Investigation of a Single-Wire Electric Power System, D.S. Strebkov, S.V. Avramenko, A.I. Nekrasov, O. A. Roschin
- Fuelless Monothermic Engine (Invention by Y. Volodko)
- On Viktor S. Grebennikov's Discoveries. Review
- Experimental Study of Properties of Time. Review
- Bedini Generator, David Mason
- Article Update for An Introduction to Gravity, Lew P. Price
- The CIP Engine Principle, Robert L. Cook
- The Energy Machine of Joseph Newman, Michael Williamson
- What is the RQM Technology? Review
- Experimental Data on Time Control by Acad. A.I. Veinik
- The Space Power Generator by P. Tewari. Review

2003, №1 (10)

- Testatika. A Review of a Well-Known Electrostatic System.
- Cold Fusion by Plasma Electrolysis of Water. Ph.M. Kanarev, T. Mizuno
- What A Cold Fusion Is and What Does It Mean to Science and Society? E. Storms
- Technical Introduction to LENR-CANR (Low Energy Nuclear Reactions). E. Storms
- It all Started in 1989... (History of Cold Fusion Development). P. Hagelstein
- A Science Tutorial (Cold fusion). T. Chubb
- LENR (Low Energy Nuclear Reactions) Experiments.
- On Electrogravitation. A.V. Lemeshko
- Avalanche-drive Propulsion Device. M.L. Filho
- Hydrogen-Powered Vehicles. P. Behr, G. Schneider
- Unusual Permanent Magnet Motors. T. Valone
- Hydrogen Energetics. A. Pashova
- On the Longitudinal Electromagnetic Waves. A.V. Frolov
- Space and Terrestrial Transportation and Energy Technologies. T.C. Loder
- Commercialising the "Searl Effect".
- Interesting Publications of the Last Year.
- "Lifter" Project
- New Electric Fire Technology. V.D. Dudyshev
- New Effect of "Cold" Evaporation. V.D. Dudyshev

- Conceptual Hurdles to New Millennium Physics. D. Reed
- Resonant Phenomena Occurring in Alternating Current Circuit. A.V. Frolov
- Books Review

2003, №2 (11)

- Minato Wheel. E. Vogels (Sweden)
- Mechanism of Drive-Free motion. S.A. Gerasimov (Russia)
- Production of Ball Lightning in Laboratory Environment. Report by A. Pashova (Russia)
- Electric Discharge Produced into Air Half-Space. G.D. Shabanov, O.M. Zhrebtsov (Russia)
- Free Energy. A.V. Frolov (Russia)
- Some General Properties of Matter and Energy Sources. E.D. Sorokodum (Russia)
- Commercial Exploration of Space. Review by O. Leontyeva (Russia).
- Prospects of Hydrogen Energetics. Ph.M. Kanarev (Russia)
- Heater Producing Healthy Effect. A.L. Belyaeva and others (Kirghizia)
- Inertial Propulsion Device. V.E. Senkevich (Russia)
- Unlimited Accelerated Nonreactive Motion. Review.
- Revolutionary Current. S.K. Baliyan (India)
- Tilley Electric Vehicle. Review.
- Trends in the Application of Motor-Generators. A. Akau (USA)
- Electric Vehicle in Russia. Review by A. Pashova (Russia)
- The Richard Clem Motor and the Conical Pump. R. Koontz (USA)
- Spontaneous Flow Heat Pump. J.-L. Brochet (France)
- Registration of Gravitational Waves. V.N. Petrov (Russia)
- High-Energy Hyper-Low-Frequency Electric Field. Yu.V. Ivanko (Ukraine)
- To the Question of Work Performed by the Electrostatic Field. A.V. Frolov (Russia)
- Comments on News on Electro-Reactive LIFTER News.
- Letters from Readers
- Advertisements (books)

2003, №3 (12)

- Work on the Designing of a Time Machines. Vadim A. Chernobrov (Russia)
- Control of Temporal Parameters of Physical Processes. Alexander V. Frolov (Russia)
- Etherodynamics as a New Field of Physics. Vladimir A. Atskovskiy (Russia)
- Electromagnetic Gravitational Interaction Vadim Ya. Kosyev (Russia)
- Medium For Existing of Matter in Nature. Anatoly V. Rykov (Russia)
- Adams Motor. Sergey S. Abramov (Russia)
- Field Transformation in the Model of Extended Space. Dmitry Yu. Tsipenyuk (Russia)
- Joe Flynn's Parallel Path Magnetic Technology. Tim Harwood (USA)
- Flynn Laboratory Photos
- Flux-machine and Its Analogues. Review
- Russian Patents on Alternative Energetics.
- Gravitational Spaceships. Gregory R. Uspensky (Russia)
- On Velocity Of Drive-Free Motion. S.A. Gerasimov, V.V. Stashenko (Russia)
- Electromagnetic Self-Action. S.A. Gerasimov, A.V. Volos (Russia)
- Uranium Photoaccumulator. Anton I. Yegorov (Russia)
- Global Energy Prize (reportage)
- Teleportation. Alla V. Pashova (Russia)
- "Mass Defect" in Home Conditions. Prokofy V. Sherbak (Russia)
- Aether as Unified Field. Alexander M. Mishin (Russia)
- Global Energy. Philip M. Kanarev (Russia)
- Fusion Processes Of Molecules Of Oxygen, Hydrogen And Water. Philip M. Kanarev (Russia)
- Plasma Energy Power Generation. Bruce A. Perreault (USA)
- News
- The Marcus Device Controversy. Tim Ventura (USA)
- Systems of conversion of thermal energy to mechanical one. Review
- I. Prigozin
- Letters

2003, №4 (13)

- Single-Wire And Wireless Electric Power Transmission. N.V. Kosinov and others (Ukraine)
- The possibility of almost complete transformation of thermal energy into mechanical one. S.N. Doonaevisky (Russia)
- Inventor Club. Review. Vector Propulsion Engine (Electromagnetic Version). A. S. Tukanov (Russia)
- Inertial Dynamic Generator. S.N. Schmidt (Russia)
- Latent Potential Energy of Electrical Field. V.D. Dudyshev (Russia)
- News
- Energy from Air. M.P. Beshok (Russia)
- A Parade of Gravitational Aircrafts. V.A. Chernobrov (Russia)
- Energy from vacuum. Review
- Meeting of Nobel Prize Laureates in Saint Petersburg
- Perpetual Motor With Magnetic Control Elements. Review
- Who Needs A Controlled Thermonuclear Fusion? I.B. Kalugin (Russia)
- Fuel cells. Edwin Cartlidge (USA)
- Free Energy. Thomas F. Valone (USA)
- Secrets of Nicola Tesla's Experiments. S.S. Makukhin (Russia)
- Alternative Cold. Review
- High-Efficiency Technology of Magnetic Cooling. E.N. Tishina (Russia)
- News
- Interference Disc Electric Generator. Alan L. Francoeur (an announcement of the future article) (Canada)
- Howard Johnson and his Motor. Review
- Bogomolov's Centrifugal Generator. V.I. Bogomolov (Russia)
- News
- Magnetic Motor. A.V. Vydrin (Russia)
- "Omega" Anomalous Hydrogen Reactor
- Gravitational Shielding. Harald Chmela (Austria)
- The Concept of Magnetic Gas

2003, №5-6 (14-15)

- News From Our Company
- Novozhilov's Motor, Y. Novozhilov, Russia
- Self-Action in the case of Magnetic Rotation, S. Gerasimov and others, Russia
- Capillary Motor, I. Elshansky, Russia
- Gravity-Heat Energy System, V. Sukhanov, Russia
- Modern Perpetual Mobile, Review
- Free Energy and Antigravitation, (Spin Wave Lasers), Ines Espinosa, USA
- Mechanical Analogies, Y. Ivanko, Ukraine
- Cell of Fine-Plasma Electrolyse, Ph. Kanarev, Russia
- Smith's Generator, Review.
- Strategy of Over-unity Devices Marketing, R. Wood, USA
- Hutchison Effect, Mark Solis, USA
- Heat Energy Conversion by Means of Non-Linear Dielectric, A Ries and others, Brasil
- Gates' Motor, A. Akau, USA
- "Cold Electricity", A. Akau, USA
- Gravity Conversion Rotary Device
- Torsion Technologies, China
- News
- Antigravitation, B. Smith, USA
- Electric Levitation, MacLeod, Canada
- Perpetual Mobile, V. Likhatchev, Russia
- Interference Generator, A. Francoeur, Canada
- A New Paradigm of Time, D. Reed, USA
- On the Rotating Permanent Magnet System, A. Frolov, Russia
- Inventor's Week, USA
- Patents on Inertial Propulsion Systems
- Bogomolov's Experiment With Spring Drive, Russia
- History of Perpetual Mobile
- Tesla Energy Science Conference, USA
- Perendev's Company, Review
- Internet Pages About Free Energy
- Matveev's Electrical Generator, Russia
- Perpetuum Motor With Magnets, France
- The most interesting of 2003
- Hydrogen Power Engineering, Review
- News on Hydrogen Fuel Cells
- Electric Discharge as Part of the Over-Unity Device, Review
- Subscription page

**You may order the CD from the office of New Energy Technologies magazine:
Lev Tolstoy Str., 7 – 601, Saint-Petersburg, 197376, Russia.
e-mail: office@faraday.ru. tel: 7 (812) 380-3844**

What Ever Happened To Black Light Power?

By **Patrick BAILEY**, President INE

New Energy News
VOLUME 10, NUMBER 11
November 2003
www.padrak.com/ine/

Power from light invisible to human eyes: Black Light Power. It was the talk of the town two years ago. It seemed to work: more energy came out (seemed to come out) than went in — so it looked like a promising new form of potential energy conversion! They obtained a US Patent! They filed for another! Life was great! And then — and then — well... — the best explanation that I have heard is that the theory people did their measurements, and came up with why the energy was being released from a new potential energy source. It was coming from collapsed states of the hydrogen atom. The good news: it seemed to be validated by experiment, measurements, and some solid nuclear theories. The bad news: it violated the current books on QM, by saying that the current ground state of hydrogen is not really the lowest energy state of hydrogen. So — whenever science has come up with proof that the current accepted theories are wrong — what happens? Yep! The scientists are publicly labeled as charlatans — the new US Patent applications were denied, and the old US Patent was withdrawn.

Why? To protect the quality of your life? No. To protect or advance science? No. To protect the reputation of the existing scientists — and — the value of all of those unsold published books? Of course! It has always happened this way... Meanwhile, this new science is probably being secretly researched in other countries. Gee, I wonder where?

BlackLight Power Inc. conducts research into new sources of energy. BlackLight is the owner of United States Patent Application No. 09/009,294 entitled “Hydride Compounds.” As described in BlackLight’s brief, the inventions claimed in this and several related patent applications and an issued patent are directed to new energy technology derived from hydrogen compounds, and new compositions including conductive magnetic plastics and corrosion-resistant high-strength coatings.

During examination of the “294 application, the examiner initially rejected the claims on various grounds including operability under 35 U.S.C. §101 and enablement and definiteness under §112. After further prosecution including discussions of experimental results and the submission of samples, the examiner withdrew the rejection and allowed the claims. A Notice of Allowance was issued on October 18, 1999, the issue fee was paid, and issuance was noticed for February 29, 2000.

Another BlackLight patent application, entitled “Lower-Energy Hydrogen Methods and Structures”, issued as United States Patent No. 6,024,935 on February 15, 2000. Shortly thereafter, prompted by an outside inquiry, the Director of the Group that had examined these applications was made aware of both the “935 patent and the

imminent issuance of the “294 application. By Declaration filed in the district court, Group Director Kepplinger stated that upon reading the patent her “main concern was the proposition that the applicant was claiming the electron going to a lower orbital in a fashion that I knew was contrary to the known laws of physics and chemistry”. Director Kepplinger believed that the “935 patent and the “294 application were directed to similar subject matter, and contacted Robert Spar, Director of the Special Program Law Office in the Office of the Deputy Assistant Commissioner for Patents. Director Spar stated by Declaration that Director Kepplinger expressed concern that the “294 application “possibly had serious and substantial patentability problems and asked me to withdraw it from issue for further review”.

On February 15, 2000 a Notice was issued to BlackLight, stating that the “294 application “is being withdrawn from issue pursuant to 37 C.F.R. 1.313... to permit reopening of prosecution... [as] requested by the Director, Special Program Law Office”. It is undisputed that no one involved in the withdrawal had reviewed the “294 patent application before issuance of the Notice; at the argument of this appeal the PTO Solicitor stated that the application was not available for review because the file was in Pennsylvania for printing of the patent document.

BlackLight’s attorneys made prompt inquiries about the withdrawal. The PTO treated the inquiries as a petition to the Commissioner requesting reversal of the withdrawal. On March 22, 2000 the petition was denied by decision of Assistant Deputy Commissioner Kunin. The decision stated that “[t]he PTO has an obligation to issue patents that meet the statutory requirements for patentability”, and concluded that Director Kepplinger did not act improperly in obtaining withdrawal of the “294 application for further examination. The decision referred to Director Kepplinger’s concern about the correctness of the scientific theory set forth in the issued “935 patent, described in the decision as “the discovery that energy was released by stimulating hydrogen atoms to relax, and, in so doing, to shrink to smaller radii, and to also attain energy levels below their “ground state” according to a “novel atomic model”” and Director Kepplinger’s belief that the “294 application was based on the same theory. The decision stated that Commissioner Kunin’s inspection of the “294 application “reveals that this invention is asserted [sic] to matters containing fractional quantum numbers. Such fractional quantum numbers do not conform to the known laws of physics and chemistry”. The decision did not further discuss patentability, but stated that the application would be returned to examination.

Meanwhile, on March 1, 2000 BlackLight filed suit against the PTO Commissioner (now denominated “Director”) in the United States District Court for the District of Columbia, charging that the withdrawal was contrary to law and in violation of the Administrative Procedure Act, 5 U.S.C. §701 et seq. BlackLight argued that 35 U.S.C. §151 compels issuance when the issue fee has been paid

SUBSCRIPTION 2004!

From any month of 2004!

To subscribe for
New Energy Technologies magazine,
please visit our web site:

<http://www.faraday.ru/net.htm>

One-year subscription
price for 2004 is \$46.00

World-wide airmail delivery
included.

In 2004 we will publish
500 copies, 4 times per year, 100 pages

Alongside the English version a Russian version
is also available.



CD "New Energy Technologies"

All the back issues of 2001–2003 are
available on a CD as PDF-format files.
The price is \$26.00.

You can order the CD here:
<http://www.faraday.ru/net.htm>



Contact information for additional requests:

Faraday Lab Ltd,
New Energy Technologies magazine,
Lev Tolstoy Str. 7–601,
St.Petersburg, 197376, Russia.

Tel/fax 7-812-380-3844