

New Energy Technologies

Magazine

Scientific news on advanced propulsion systems for aerospace industry and new energy technologies

Issue #3 (18) 2004

CONTENTS

Commercialization of alternative energetics, Alexander V. Frolov, Russia	2
Potapov's molecular engine and water vortex heat generator	4
New Products: Autonomous electrostation with molecular engine	9
Magneto-hydrodynamic motor, S. Gerasimov, Russia	10
Inertial drive, E. Linevitch, A. Ezov, Russia	12
Plane Earth as electromotor-generator, V. Dudishev, Russia	17
High efficient method to obtain hydrogen and oxygen from water, V. Ermakov, Russia	24
Inertial generator, V. Gilchuk, Russia	25
Chemo-electrical gravito-electrolysis by V. Studennikov's way, A. Makarov, Russia	26
Sun water pump, Yu. Novozilov, Russia	30
Semiconductor electromagnetic energy transformer, A. Zerniy, Ukraina	32
Prof. Alfred Evert's research, Germany	34
Prospects for Breakthrough Propulsion from physics, M. Millis, USA	40
Phenomenon of direct transformation of magnet field energy, V. Dudishev, Russia	51
Electrostatic generator, USA patent 4,897,592	59
Vortex drive, Alexander V. Frolov, Russia	63
Magratten's magnet pulsed DC motor-generator	69
Over unity propulsion of zero potential casing asymmetric capacitor system, Nassikas A.A.	73
On the nature of electrical force interactions, Alexander V. Frolov, Russia	80
New products: Water vortex heaters, prices and technical data	82
Antigravity Secret, Tim Ventura, USA	84
Information about CD "NET 2001-2004"	93

Publisher: Faraday Lab Ltd 4 issues in 2004

Editor-in-Chief Alexander V. Frolov, **Scientific Advisor** Kirill P. Butusov,
Technical Editor Svetlana A. Schlenchak

Correspondence Address: 7 Lev Tolstoy Str., St-Petersburg 197376 Russia,

Tel/fax: 7 (812) 380-3844, net@faraday.ru, <http://www.faraday.ru>

Cost of this issue: \$46 (with CD of all the back issues as PDF files).

Printed in Russia. Copyright © 2004 by Faraday Lab Ltd.

Circulation of this issue in English: 200 printed copies

Information reported in New Energy Technologies magazine is not necessary endorsed by the publisher or staff.
In many cases information received cannot be verified, though we try to report the news as accurately as possible.

Commercialization of alternative energetics

The stages of the civilization development are characterized by methods of the energy production. The steam machines were pushed out by internal combustion engines, and the determination "a kilowatt in an hour" being used today much more often, than "horsepower". Our civilization develops along the technocratic way, almost without of paying attention to existing natural methods of the energy transformations. The burning of the oil or the other kind of fuel is not a natural source of energy. Rather, it is the result of a catastrophe, for example as in the case of a forest fire. The Nature uses other physical principles. Let us give you a few examples.

It is obvious that the heat radiation of Sun is the basis of the energetics for many processes on our planet, including the formation of the organic fuel. That's why to study the question about physical mechanics of a star energy has a fundamental meaning. In modern astrophysics more and more recognition receives the energy conversion theory and it is pressing out the thermonuclear theory of the star's energy source. Even N.A. Kozyrev considered the stars as machines transforming energy of one kind (he called it the energy of the time flow), to another kind of energy, for example, to heat EM photon radiation: "The absence of the energy sources shows that in a star does not exist its own stock of energy, but a star uses the energy that comes from other external sources. Stars in the Universe exist everywhere, and they form different structures. That is why the very possibility of energy coming by one way or another way must have something in common with what space and time have. Space is passive - it is like an arena on which the events take place. Time can be not only a forth dimension, (in addition to three-dimensional space), but a natural phenomenon. The existence of active or physical properties of time must lead joint reaction of time and of some other processes happening (going on) in the Universe. When time acts upon a substance it can give that some energy and serve as the source that supports the life of the stars". (Kozyrev N.A., Selected works, 1991, Leningrad University publishing).

Let us note that our company Faraday Lab has conducted some experimental researches of the active conditions of time in order circle the relevant tasks in the energetics, space technology, and searching for a new ways to manage radioactivity, but not for organizing of "time traveling", even it is an interesting topic.

Unfortunately, a simple reproduction of the processes that are happening inside of the stars is not possible in a laboratory conditions. That is why the Kozyrev's theory and experimental information are being criticized and not accepted by thermonuclear theory followers. Practical solution in the given area is concluded from the understanding of the very possibility of longitudinal photons to transverse photons transformation, which was noticed by Saint-Petersburg's astrophysician A. G. Shlenov. Besides astrophysics, the related processes are well studied in the plasma physics; however the classical approach is not focused at the fuel less energetics tasks. Rare practical researches in this area let some authors to build fuel less energy transformers that work on the same principles that Nature uses in stars. This is serious step away from catastrophic fuel burning energetics towards the natural fuel less energetics. The realization of the mentioned principles was proved by A. Chernetskii who made some experiments, offered conclusions and the theoretical base for the vacuum energy transition mechanics of the virtual particles energy to plasma electrons in an electromagnetic wave with a longitudinal component. (A.V. Chernetskii, To physical nature of bioenergetics phenomenons and their modeling, 1989, Moscow, VZPI publishing).

Remarkably, the development of the given ideas insists on the widening of our believes about space and time's structure, about vacuum physics conditions, i.e. multidimensional perception of Nature, that need to be formed by the students at the stage of completing the higher technical education. Even though the modern physics classical authors were relating electron to the 4-dimensional class object, nevertheless the

understanding that any matter is a process and its parameters could be designed, and energetics may be not only fuel-burning, were not shaped completely yet at the most engineers-constructors level of thinking.

A well known phenomenon of "tornado" forces us to think of a possibility of vortex processes to be used by energetics. Of course we are not talking here about "catching" and practically using a tornado. The understanding of the vortex processes allows us to design a highly efficient water heaters and extremely powerful and compact autonomous energy generators. Today, it is not merely scientific speculations, but a real product offered for the market. Our company Faraday Lab Ltd., for example, offers to interested organizations to buy autonomous electric stations with a fuel less air vortex molecular engine of 200KW, 600KW , 1 MW and more power that can be produced by our partner's factory. This is a qualitatively new product on the autonomous sources of electric power market, because these electro stations work without any fuel. Air, which takes part in the vortex process is quite good for breezing after operation, that allow using of this technology in any closed spaces. You can read more about it in this issue in Y.S. Potapov's article (p.4) and in our advertisement on page 9.

In principle, there's no urgent problem with the new energy technologies innovation, because Russia has enough oil for another 50 years. However, it is known, that about ten to twenty years are necessary from the idea to its market realization. So, it is necessary to start the commercialization of the new energy technologies in Russia today, since it can be too late in future, because of other countries do not have such greates oil resources like Russian oil stores, and that's why they give the alternative energetics much more attention, than Russian politicians.

Let's note also, that a replacement of a one kind of the fuel for another (hydrogen) can not solve the energy problem. Our civilization needs to switch to the autonomous energy sources, but it does not lead to a "revolution". The fuel less electro stations are not competitors to the oil companies, because these technologies open an absolutely new independent segment of the market, including the space program. More to it, this is the only way of the industrial development of Russian far regions

that have an unprofitable fuel energetics and for that reason it is not developing. For the state program realization in the given area of Russia's strategic interests is important to create a Ministry or a Department of fuel less energetics.

Some words about our perspectives (publication of New Energy Technologies magazine). During three years of our work we published different experimental news, including news about antigravitation, high efficient generators with permanent magnets, about achievements of the hydrogen energetics, articles about direct transformation of environmental heat into electric power, a description of the working devices, which are using the capillary phenomenons, and also different mechanical devices, that let, as many authors say, to get the spinning point at the shaft without an external source of energy.

Sure, many articles were accepted by our readers critically, but the magazine, of course, has benefited the society analyzing of the existing advanced experimental works and theoretical ideas. The number of subscribers was growing steadily, but now it is about ten times less than it is necessary for the magazine's economical stability. We made a few attempts to increase sales in cooperation with the distributors of printed issues in 2003 and 2004. Unfortunately, as we learned, usual reader prefers "Cosmopolitan", "Playboy" and magazines about autocars.

Today we have to make a decision about future plans on our magazine to publish it in the next year or to close it. We hope that we can find some sponsors to continue work in 2005. The practice shows that we need \$60,000 - \$80,000 for one year. Financing for 2005 period we must get before November of 2004.

Companies, funds, organizations and private persons, who want to give us some help, can call us 812-3803844 or e-mail office@faraday.ru

Alexander V. Frolov

*New Energy Technologies, Editor in chief
Faraday Lab Ltd, General Director*

Potapov's molecular engine and the vortex heat generator

work autonomously on water and air without fuel

Potapov Yu. S.

Phone: 8-911-263-1428, e-mail spotapov@mednet.md



Fig.1

The author has in his hands a molecular engine 5 kilowatt powerful at 50000 rotations in a minute.

It was created in Russia a molecular engine working without burning of any fuel, and with efficiency that twice exceeds the efficiency of internal combustion engines and efficiency of Sterling's engine. The main ecological problem is solved. The engine does not have any fumes, it does not burn oxygen, and it does not have any chemical oxidizing processes, associated with all known engines that work on liquid, gaseous or solid fuels. The tests on the new engine showed that it holds the programmed load without lowering the revolution. The new engine beats all known to the science engines in its construction simplicity and in stability; it is superior also to all famous gas turbines. The engine consists only of three main details: of the stator, the rotor and the vortex camera. Perhaps, the new engine does not have any

analogies in the world practice. Even all of the producers were surprised while tested the new engine on the test bench. It could not be started with the pressed air with the pressure of 1 atm. (Editors note: the authors use the determination "pressure" omitting the words "more than 1 atm", i.e. "1 atm of pressure" for them is 2 atm). With the pressure like that the rotor was developing extra high revolutions and the bearings were falling apart instantly. Then the bearings, holding 50,000 rpm, were installed. But the picture has repeated. An idea came through to lower the air pressure in 10 times. It was tried and again everybody was surprised. All people, attending the test, saw, that the new engine had raised the revolutions up to 21,000 rpm under 0.01 atm of the air pressure.

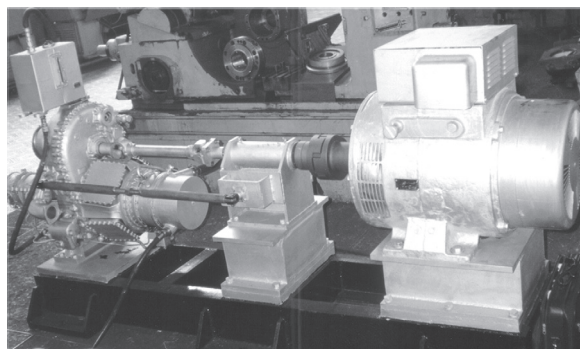

Fig.2.

This is an autonomous electric station of 50 kilowatt power, with a molecular engine. The new station of 37 kilowatt power will be built in 2004 for Faraday Lab Ltd.

We got 50,000 rpm raising the air pressure up to 0.09 atm. The received engine's revolutions and a huge rotating moment through the reduction at the power selection axle provide a stable work with a load. The beforehand calculations showed that for the autonomous work schedule of the new engine

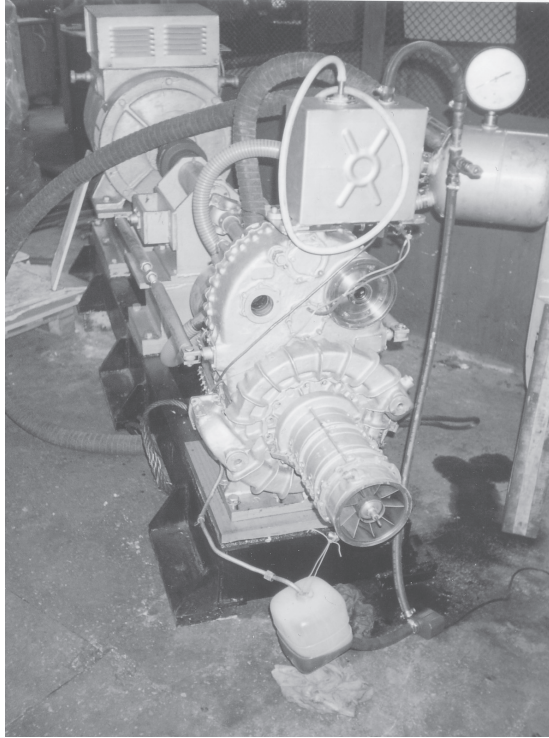

Fig.3.
This is an autonomous 50 KW electric station.
View from the turbine's side.

will be needed about 30% of the created energy, in order to recuperate the energy about the system that is providing the air stream. But the practice made its corrections once again. When the engine was build in the real proportions with the generator, then for the energy recuperation were needed not 30 %, but only 15%, which has significantly raised the molecular efficiency of engine.

Talking about the engines and about the efficiency of existing electric stations let's point that efficiency of Sterling's engine is up to 45%, nuclear electric stations – up to 34%, diesel electric stations – up to 35%; efficiency of heat electric centers is about 26%, wind power stations – up to 30%, solar panels (batteries) – up to 12%. The efficiency of molecular engine is 85%, and prospectively it can work with a efficiency close to 100%.

Editor's note: In this case, the expression "efficiency=85%" means that on an autonomous work mode, i.e. without any fuel income or of an external source of energy, this

electric station gives away to the consumer 85% of the produced energy and leaves for itself 15% for its compressor. From the other point of view, since there is no fuel use in this construction and no external source, then its effectiveness is infinite great. Alexander V. Frolov.

Production of the heat on the base of the autonomous vortex heat generators.

The substitution of the old heat energy producing sources on ecologically clean ones replaceable sources of energy can bring essential economic and ecological benefits. It was calculated in Germany, that a efficiency increase of 10% at the heat stations brings a saving of 30% of fuel. In other words, we can considerably save of the burning fuel and then direct it the other more important targets, only expenses is the building cost of the autonomous heat generators.

A thermal electric station that is working on air and water, provides not only the economy of fuel, but also decides the eternal problem of heating lines' repairing and of their installation in city conditions. Decentralized heating and hot water supply will bring impressive achievements to all population and to the state, and it's obvious.

As the academic of The Russian Academy Of Sciences, the international prize's "The global energy" laureate Alexander Efimovich Sheidlin has said wisely, there is no need to "smash" anything and throw away to the history's damp, because the old and the new energetics do not contradict each other, but in opposite way favorably comply each other. By the way, A.E. Sheidlin has given us a positive remark about the vortex thermal generators after their demonstration in the international science-technology center of space object's useful loads. The development of works on vortex thermal generators that are working on water allows us to join successfully the molecular autonomous engine with the vortex thermal generators. In this case the heat energy's production also will be an autonomous process with a efficiency, which we let the future users to evaluate.

Because the vortex thermal generators of the

first generation work for more than 10 years and are build in many countries: in Russia, in Ukraine, in Byelorussia, China, France, Germany, USA and in other countries, some different statistical data is being accumulated. One of the global factors of the vortex thermal generators, by our opinion, is not even the peak efficiency but economy of fuel, that each year is harder to get, and its collection places go further and deeper.

Many questions concern the physics of the processes that happen in vortex heat generators (VHG). By our opinion is based on the 15 year long researches: it is known that in a VHG three processes take place at the same time. In a VHG a vortex process appears which in 10-15 seconds fills the entire vortex pipe. The birth of the vortex process starts in the center of the cylindrical body of a VHG, at the point, which is visible to the naked eye. This was noticed first in the clear glass VHG in NIC RKK "Energia" named after S.P. Korolev.

All three known physical phenomenons as such:

1. The friction during the fast spinning of water (including the levels' of the water friction).
2. Cavitation balls in water stream, which do not touch the walls of VHG.
3. Water molecular synthesis. During fast spinning the water molecules connect in associates. And during it the biggest portion of the heat energy extracts.

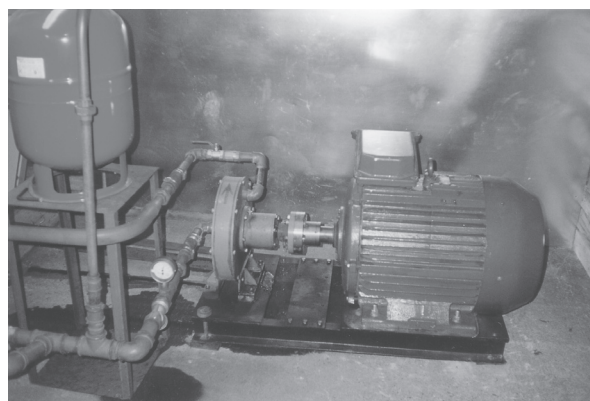

Fig.4
Potapov's thermalgenerator of the seventh generation

The scientists established that if you connect 10% of all water molecules in associates, then the water boils immediately. From here the main factor of extra energy was determined. On a base of hundreds of conducted experiments was established, that the spinning movement, or the vortex movement, of liquid raises the water molecules synthesis process in three times compare to in a straight line movement.

Happened, that the water molecules synthesis phenomenon prevails on the rest of the phenomenons on heat extraction. It was confirmed later by works of professors F.M. Kanarev (Russia) and Misuno (Japan). In the laboratory conditions they got the efficiency coefficient number, which equals 40.53;42.15;41/07. In other words, data on ratio between extracted energy and input energy is more than 4000%. By our opinion, these numbers are far from the limit. Today good perspectives on the future VHG use are open.

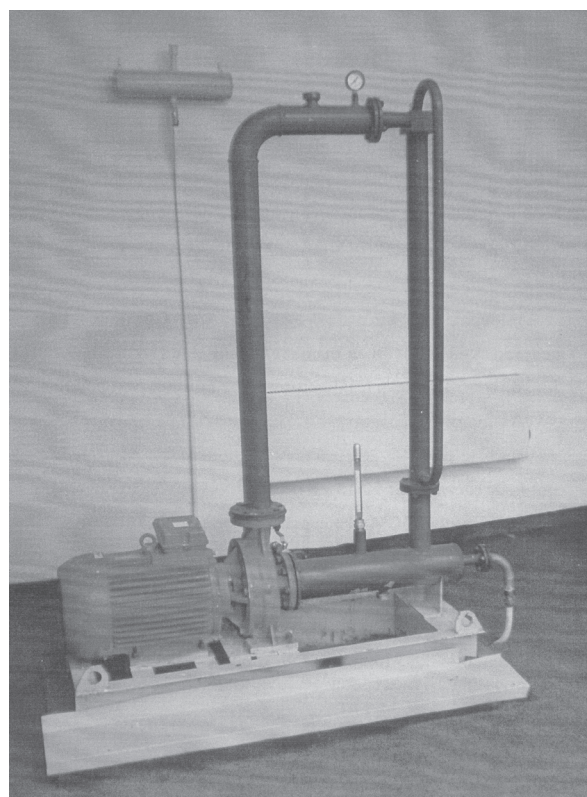

Fig.5
Heat generator

In the nearest time VHG already will be working without an electric motor and with a efficiency equal to infinity.

However, as it usually happens, starts an allover production of new vortex thermal generators by dilettantes in this area, and, accordingly, the effectiveness of VHG does not bother them. They are interested in super wealth. That is why, only attributing to the author let on a scientific base successfully produce and use new VHG and molecular engines.

Today, works on steam getting on VHG go on, the thermal generators of the seventh generation are updated and their construction is simplified. If in the first generation VHG only one vortex worked, then in the eighth generation more than 500 000 vortex processes in a minute are created. The water, when it flows through a new VHG, heats up to 95 degrees C in one step. Naturally, the new VHGs' effectiveness raised in a few times. Works on studying and perfection of VHG take place in Moscow, Saint-Petersburg, Kovrov and Izhevsk. New directions in science appear, using VHG in medicine and agriculture. The quantity of publications about vortex energetics has raised dramatically.

Our monographies "The vortex energetics and the cold nuclear synsesis from the movement theorie's point of view", "The rotaition energy", How does the thermal generator of Potapov work", "Energy from water and air for agriculture and industry". Many patents of Russia and other countries are received. Formed forms RST in 96 countries, but the basic is the patent of RF #2045715 "The thermal generator and the device of heating of liquids" with a priority from April, 26 1993 by author Y.S. Potapov. More than ten years were needed to begin of the widespread use of VHG process.

Molecular engines for the vehicles and surface cars.

It would be very good, if buying a car, the owner could move around an eternal time without fuel stops. That's why electro mobiles, cars on solar panels, with wind engines, with magnet engines with DVS and electric generators, with hydrogen engines, with steam engines and

many other exotic or empty projects started to appear. But, still, there is no efficient decision of this problem in sight. All of the engines that burn fuel and terminate oxygen make an unfixable harm to the environment and people. That's why they have no future. A simple calculation shows that during of the burning of 10 liters of gas 3000 liters of air are used. The air from the combustion is no good for breezing (even with a catalytic converter). For example, 3 millions of cars drive every day in Moscow. Let's take the time of their work to be equal to 6 hours. Coming out:

$$V_{gas}=3\ 000\ 000 \times 6 \times 3000 = 54000000000 \text{ liters.}$$

Such quantity of the poisoned air can lead to a catastrophe. More to this, the poisoned air does not have a harsh smell and it does not have an unpleasant taste. Except for this one, there are more than 200 names of poisoning and cancerogenic substances, creating during gas burning and its connection with the air's asot and oxygen. That is why, it is necessary to speed up the transportation' transition to molecular engines.

The other very important problem in transportation is accidents and catastrophes. In relation with the quantity of cars, their speed and breaking the traffic rules in Russia more than 30 thousand people died and in three and a half times more get serious injuries. It is impossible to stop this by the traditional means. With a hard construction of cars heavy consequences in a way of accidents and catastrophes are not avoidable. That is why, by our

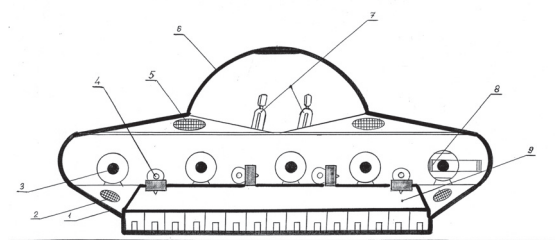

Fig.6

The car for four people: 1 – the body is soft, inflatable; 2 – the air receptor; 3 – the fan; 4 – the molecular engine; 5 – the air receptor; 6 – the cabin is look through; 7 – inflatable seats; 8 – the march engine; 9 – the air pillow's camera

opinion, cars should be soft like a ball – surface ones, and the passengers should stay in air seats.

The second, cars should not be attached to the road. They should fly steadily.

The third, It is important to exclude the human factor in the surface cars motion. The motion of a surface car from the point A to the point B must be accomplished in automatic regime around the coordination net without a man's involvement.

For the two established tasks decision (counting that the molecular engine for the surface car was already created) it is necessary to use new highly strong materials textiles, which would not break during an accident. These materials must be of two kinds: a) transparent – for the passengers' cabin and b) not transparent for the car's body. The space experience of inflatable surfaces for the instrument parts could be used. The air is pumped with a small pressure in between of two walls and the car gets a smooth form in a few seconds. The board computer system has a satellite navigation system of orientation in space. It is enough for the passengers to press the buttons and make necessary coordinates of the landing point.

The surface car can land on water and earth alike. It can hang in the air in any pointed to it point, using four or more of molecular engines. For the surface car roads are not needed, the eternal Russian problem of the bad roads goes away. The surface cars accomplish their motion on the heights of 20 to 200 meters in an automatic mode. They may park next to each other or like stacks.

The speed of their motion and directions of moving chooses the computer, therefore even during a collision passengers do not get injured or die, because surface cars jump away from each other; the same happens and during a crush landing. There should be a thrice stock of engines on board. The possibility of the engines' failure is practically absent. The vortex molecular engines' nominal drive is considerably higher than in a helicopter. Their resource can be raised up 200000 hours of constant work. We offer to the interested companies and investors to start producing the surface cars with new engines in 2004. This is one of the directions of our work.

Academic Yu.S. Potapov's publications

1. Potapov Y.S. Patent of RF N2045715 "The thermal generator and the liquids heating device". The priority from April, 26 1993.
2. Potapov Y.S. Patent PM N167 "Thermogenerator si dispozitive pentry incalzirea licheidelor". The priority from March, 1993.
3. Potapov Y.S. and clermo jean. France patent "Thermal generator N9310527. The priority from September, 9 1993.
4. Potapov Y.S. "Certificat de inregistrare" N8. PM.From January 1994.
5. Potapov Y.S., Potapov S.Y. Patent PMN1213, BoPI N04/99, 26.02.1999.
6. Potapov Y.S., Gen Gvan Cher. Application PCT KR "The hydraulic quant motor" from 18.08.1998.
7. Potapov Y.S., Gen Gvan Cher. Application PCT KR "The wind energy station" from 18.08.1998.
8. Potapov Y.S., Potapov S.I. Book "Energy from water and air for agriculture and industry", 87 pages, 1999.
9. Potapov Y.S., Book "The vortex energetics and the cold nuclear synthesis from the motion theory's positions", K.-4.2000.
10. Potapov Y.S. Phominskii L.P., Potapov S.Y. The energy of rotation.K.2001, 375 pages
11. Potapov Y.S. and others Patent RFN2165054 "The heat receiving method" The priority from 16.06.2000.
12. Potapov Y.S. and others Patent Ru N47535 The priority from 18.05.2000.
13. Potapov Y.S. and others The application PCT WO 01/96793A1 "The heat receiving method" The priority from 01.11.200.
14. Potapov Y.S. and others Patent RUN52985A "The liquids heating device". The priority from 17.01.2002.
15. Potapov Y.S. The application RFN133221 "A method and device for the thermal energy production" The priority from 14.11.2003.
16. Potapov Y.S. The application RF N133182 "Method and device for the electrical and mechanical energy production". The priority from 14.11.2003
17. Potapov Y.S and others Patent RU N38030 "Method of getting the reactive drive for the spaceships". Priority from 18.05.2000.
18. Potapov Y.S The new energetics. N1 (16) 2004. "The vortex generator of Potapov", pages 15-16

New product

Autonomous electro station with molecular engine of 1000 KW power

Autonomous electro station with molecular engine (AESME) designed to produce electrical power as 380 VAC 50Hz (or 60 Hz). Molecular engine of the AESME is operating with usual low pressure air without fuel burning. Output flow of the air (after it produce useful work) can be applied for breath since its physical properties are the same. Starting of the AESME must be produced from external power source and then the station is working in autonomous mode as generator of energy. Power output in the autonomous mode of operation is used for own needs (about 15%) and for useful load (about 85%). So, we can say that efficiency of this autonomous generator is 85%. With full load the molecular engine is operating with constant rate (rotation per min).

Some technical data

Generator	SG99M1-12
Voltage	380-400
Frequency	50-60
Nominal power output KVA/KW	1276/1088
Max rpm of molecular engine	10000
Generator rpm	500
Efficiency of generator	0.8
Insulation class	H
Generator standards	ISO 8528-3 IEC 34 (EN 60034)
Life time of AESME (hours)	70000
Warranty period (months)	12
	Size (mm)
Length	4528
Side	2980
Height	2450

New method of energy generation is patented. License sales are possible.

Orders can be directed to official representative of the factory – producer:

Faraday Lab Ltd., Lev Tolstoy Str. 7, St.-Petersburg, 197376, Russia.

Tel/fax 7-812-3803844

Email: office@faraday.ru

Web site: <http://www.faraday.ru>

Demonstration of the technology is possible as 37 KW generator.

MAGNETOHYDRODYNAMIC MOTOR

S.A. Gerasimov

Faculty of Physics, Rostov State University,
Rostov-on-Don, 344090, Russia
E-mail: GSIM1953@MAIL.RU



hydrodynamics. After all, this kind of transposition can be interpreted as a result of the reactive motion just so a propeller may be considered as a reactive propulsive device. This analogy is not very rough. The aim of this article is to describe a real magnetic hydrodynamic machine which acts with the violating Newton's third law [2]. The work of this machine is based on the so-called SAIL-effect that takes place in a case of motion of magnet in a conducting liquid [3]. This effect based on the moving particles of conducting liquid under acting the magnetic field of a magnet push the magnet in the same direction. Below is the description of such machine.

Construction and the principle of a magnetohydrodynamic engine (MHD-motor) are described. The experimental values of the torque acting on the rotor of the MHD-motor are presented.

Magnetohydrodynamics is a branch of physics that studies behavior of liquid in the magnetic field. The most interesting application of magnetohydrodynamics is the so-called project "Yamato-1" [1]. The motion of ship "Yamato-1" is believed to be results of reactive motion. This is nothing else than the prejudice. It is not an aim of this article to criticize the authors of such practical applications of magnetic

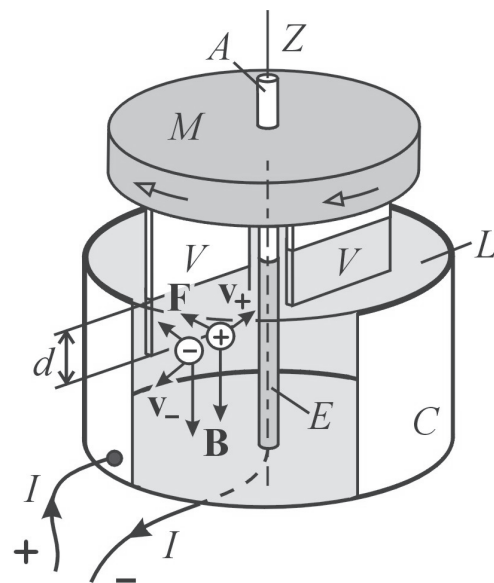

Fig. 1.

Construction of the magnetohydrodynamic engine

A cylindrical carbon-steel magnet M (of magnetization $2.0 \cdot 10^5$ A/m, of outer radius 55 mm and height 25 mm) can rotate around a non-conducting axle A mounted on the top of a central electrode E. In a case of precise measurements, the axle must be replaced by thin thread Z. The magnet is furnished with two rectangle thin (about 1mm) vanes (of height 45 mm and diametrical size 50 mm) made of plastic.

The magnet is located axially symmetrically with a vessel C (of height 50 mm and diameter 150 mm) so that the vanes are partly or entirely submerged in a conducting liquid L. The cylindrical surface C of the vessel and the central electrode E (of diameter 5mm) are made from cooper. The bottom of the vessel is insulator, of course. In this experiment, the conducting fluid is 10% copper sulphate solution ($\text{CuSO}_4 \cdot 5\text{H}_2\text{O}$).

The height of the central electrode is equal to one of the vessel.

When the direct current of strength I flows in the electric circuit, the magnet and the liquid in the vessel rotate together in the direction of the magnetic force F as shown in Fig. 1. The rotation of the conducting liquid in the vessel is caused by the Lorentz forces F exerted by the magnet on positive and negative ions drifting with velocities v_+ and v_- , respectively, in the magnetic field of inductance B. In fact, the magnetized body situated above the conducting liquid pushes the liquid out in the direction perpendicular the magnetization of the body and the density of the electric current. Having acted on the vines this volume of the liquid carries the magnet. This is the sail-effect in which each vine plays role of a sail.

Note, first of all, that this system differs from the thruster system "Yamato-1" principally. Namely, in this system the liquid and the magnet move in one direction. In case of propulsion system "Yamato-1", the water and the ship move in opposite directions.

The construction and its parameters are original. Therefore experimental results confirming reality of such a device are necessary. The set of the experimental data that tells us

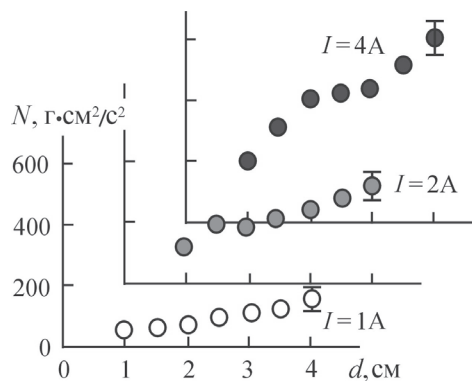

Fig. 2. Experimental values of the torque N exerted on the rotor of the MHD-motor at various depths of immersion d and strengths of direct current I.

about values of the torque acting on the mobile part of the MHD-motor is shown in Fig. 2. These are the dependencies of the torque N on the depth of immersion d at various values of direct current I. In any case, experimental magnitudes of the torque N are significant. It is interesting to note existence of a diapason of the immersion depths where the torque does not practically change. It would be a good thing to test this result in detail. There exists a lot of possibilities to improve the parameters of this MHD-motor. One way to do this is to use a magnet with higher magnetization. The second method is to optimize the geometry of the system. Theoretical calculation can be useful here. Another way is to change the profile of the vines. This will enable to increase the net effective force which charged particles transfer to the vines and, therefore, to the rotor of the MHD-motor.

References

1. Takezawa S. et al. Operation of the Thruster Superconducting Electromagnetohydrodynamic Propulsion Ship 'YAMATO-1'. // Bulletin of MESJ. 1995. V. 23. N 1. P. 46-55.
2. Gerasimov S.A. Self-Interaction and Vector Potential in Magnetostatics. // Physica Scripta. 1997. V. 56. P. 462-464.
3. Gerasimov S.A., Volos A.V. On Motion of Magnet in Conducting Fluid. // Problems of Applied Physics. 2001. V. 7. P. 26-27.

The inertial motor

E.I. Linevich, A.F. Ezshov

Russia, 690091, Primorskii district, Vladivostok, Aleutskaya street, 14-a , room 303,
phone (4232)52-41-81, (4232)20-58-37. E-mail: 524181@mail.ru

This is a close look at the action principles of a supportless inertial engine, which may be used as the power support for many different machines, including the spaceships. This device contains a gyroscope, an electric motor with an unbalance with a possibility of the free line - limbic movements, and a control system.

By now, the inventors created quite many different things and technologies that belong to the alternative energetics (to learn more about it we recommend you to look in the previous issues of "New Energy Technologies" magazine: <http://www.faraday.ru>).

The inertion engine (or "inertor") is related to the same area of technical science, and it advances, in our opinion, by its total capabilities, all devices of similar use invented before it. In a way it had been unexpected for us to comprehend the fact that inertor can be used in the same time not only as a power supply for different devices, but also as a source of energy of unlimited volume. Before explaining its action principles, let us clear out the essence of the determination "power" in Newtonian theory.

In his time, one of the well-recognized thinkers of 20th century physician Freeman has said: "...The true meaning of the Newtonian theory is following: it is supposed that power has independent qualities in addition to $F = ma$ (the second law of Newton) law, but real independent qualities of power were not described fully yet nether by Newton, nor by somebody else..." (Feynman's physics lectures, issue 1, pg. 209-210, "Mir", 1965).

For example, we do not even think about physical essence of a phenomenon, when we say: "If act with a force on a body, then it speeds up straightly proportional to this force and reversely proportional to body's mass."

In reality, the case of a force appearance is the body's acceleration, and the consequence - the reaction of its mass to the speed change in a way of inertion, applied to another body (to the one that transmits this acceleration). At the same time, with this force of inertion another active equal in numbers force appears, that is described by the second law of Newton. In other words, if there was not any mass's counteraction in nature as of the reaction to its acceleration, then the acting force would be absent. Therefore, the inertion power (as a phenomenon) has an independent characteristic of the body mass and space, being the external force for any mechanical cooperation at the same time.

The law of preservation of emanation of the material body's system is the consequence of the second and the third laws of Newton, which is a generalization of the experimental facts. The bodies act in pairs, and the forces of their interactions (including the inertion forces) are in pairs equal, aimed in opposite directions and therefore cannot be moved aside of the general center of system's mass. During the cyclic interactions of the bodies (line-limbic or rotating), all actual forces change their ways also in pairs and in cycles, and that means they still can not change the position of the center of system's masses.

We can say now, that any author, which asserts that he invented a supportless motor, in which the pulling force is created by centrifugal force, - is mistaken. If even a support-less effect in his gadget even does not exist, it is not only due to the absence of the centrifugal force. It is principally impossible to create one way pull with its help. Nevertheless, body's inertia can be used for moving in supportless space.

There is some kind of a body motion – free line-limbic process (for example, like physical limbo

has), that is possibly organized in a way, so the tangential acceleration in the given direction of the limbo will not change the direction during the all period of oscillation.

Process like that was accomplished in the inertor.

Gyroscope is used in inertor for transformation of the rotation body's motion (the unbalance) to straighten the line motion. We think it is important to remind the reader about the free gyroscope qualities:

1. Gyroscope has an inertial field (and it is the same with the field of its own gyroscope's rotation).
2. If a moment MP is applied to the inertial field, then the gyroscope turns on 90 degrees its vector on the way of its own rotating.
3. Gyroscope resists the horizontally splinted turn of its inertial field with the force, which is proportional to MP moment's value. (With it, the higher the speed of inertial field's turning, the higher the counteracting moment).
4. The acting MP and the counteracting moment of MP gyroscope are equal in numbers and always opposite to each other.
5. Influenced by constant horizontal moment MP, the gyroscope's inertial field rotation (precesses) with the constant speed (around MP moment's vector, turned on 90 degrees). That means that the field together with the gyroscope turns without an acceleration!

On picture 1 showed a scheme, explaining the principle of inertor's action (the inertor showed on it in a vertical cut). On pictures 3 and 4 a variation of motor's composition showed. The gadget has a drive, which is an electric motor, containing the stator 3 and the empty rotor 6. Inside of the stator 3 the gyroscope 1 is positioned. M – its vector of the kinetic moment. The unbalance 7 is attached to the rotor 6. The motor is connected with the spindle 19 to the transport 16's body with the possibility of a free rotation around it. The stator 3 and the rotor 6 can freely spin as relatively to each other as together on the common spindle 9. The sensor 20 is positioned on body 12, and it designed to control the angle position of the unbalance 7. Points a, b and c relates to the trajectory of the unbalance 7 mass center's rotation around the axis Y. r – the radius of the unbalance 7 mass center's rotation. In addition to it, the device of the reverse motor control and some

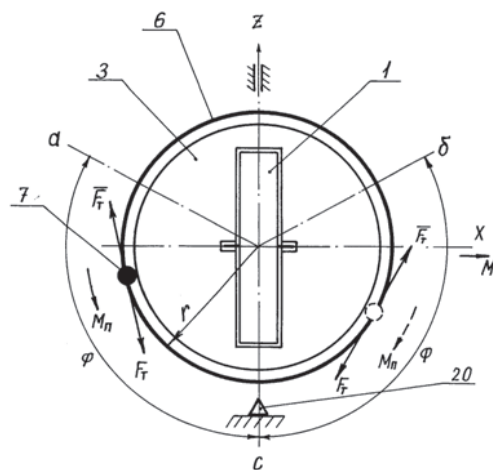

Fig.1

more additional elements, which are not showed on picture 1 were added to the drive's composition. On a work schedule the inertor's drive supplies free line - limbic movement of the unbalance 7 around axis Y with the angle amplitude of ϕ .

Let's look closer at this process. In the static condition the center of the unbalance 7's mass positioned in the point a, and gyroscope 1 is rotated to the necessary value of the kinetic moment $M = J \cdot \omega$, where J is the gyroscope's inertial moment, ω – its own circle frequency of gyroscope's rotation. The drive turns on, and the energy goes to the electric motor. At this, the rotor 6 and the unbalance 7 start to accelerate under the influence of the starting moment MP. At the same time, the starting moment MP according to the third law of Newton is applied to the stator 3 (in the opposite way considering the rotor 6 direction), and to the gyroscope 1. The last one does not let the stator 3 to spin around the axis Y and only turns the whole drive on spindle 19 around the axis Z. The acceleration of the unbalance 7 continues to the point c. Follow the sensor's 20 command the motor switches in reverse and the MP moment of the dive changes its direction on the opposite. Under its influence the rotor 6 and the unbalance 7 slow down their rotation speed till the complete stop at the point 6, and then another cycle of their acceleration starts, but in a reverse direction to the point c, during which all of the drive also changes direction of its turn around axis Z. In the point c at the sensor's 20 command the switch of motor's reverse

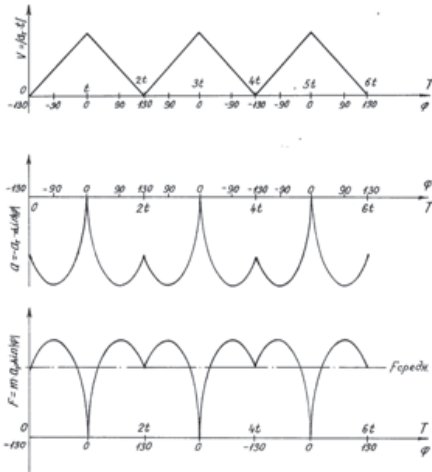

Fig.2

takes place again, and drive's MP moment again changes its direction. Under the influence of the starting moment MP, the rotor 6 and the unbalance 7 start to slow down the rotation speed, till the complete stop in the point a. The first oscillation period finishes and the next one that is identical to the above mentioned one starts.

On Fig. 2 showed how from the angle ϕ and the time T to change tangential speed V of the unbalance, projection a on tangential acceleration axis and the value of drive force F of the inertor (the projection of tangential force of the inertia FT 's unbalance on axis Z). Therefore, the unbalance oscillation period consists of the four subcycles of equal continuity t , with what in every odd subcycle (starting with the first onem the starting one) is acceleration and in every even subcycle is deceleration. During every subcycle, every oscillation period and the time of the drive's work in general, the projection of the tangential inertial force FT on axis Z does not change its direction (its direction always the same with the direction on the axis Z). This means that the whole drive together with the vehicle's body will be moving in space with acceleration in direction of the axis Z . Let us notice, that the existence of inertial power forces itself talks in defense of the gravitational expansion of the universe hypothesis. So long we can say that the work on the moving of the inertor in space is done by space itself or even by the universal gravitation. This means, for instance, that the time and the distance of its flight in space are not dependent upon the size of its board stock of energy. In inertor the reversing schedule may be conducted, inclusively

by changing the direction of the current through the included in the resonance frame of the electronic generator's electric motor's winding. The coefficient of the practical use (CPU) of a device like that is high. Imagine that our spaceship has an engine like this one. Lets take its CPU = 0.7. Then during the whole flight the board source of energy must only compensate the losses of power equal 30%. Considering all that, to get to Jupiter a board stock of energy that equals to the burning of 190kg of kerosene is needed!

Here is some more advises for those who want to build an inertor by themselves. When the asynchronized electric motor with a power of a few kWt starts, then its rotor accelerates to the nominal rotation frequency (50kHz) approximately in 0.5 second. The inertor's efficiency is higher when the radius of the unbalance oscillation is smaller and its mass is bigger, that is why for $r = 1-3$ mm the value of the tangential acceleration will be about 2 meters per second in square, and the driving force – about 20 N with an unbalance with a mass of 10 kg. It is not possible to raise the rotor's acceleration essentially in the asynchronous motor (and that is its principle deficiency), it does not let to raise the inertor's drive dramatically. Much better starting qualities the permanent current engine has. In each case it is necessary to lower the rotor's own inertial moment in every way, to make it empty inside and at the same time with the biggest diameter that is possible. In order for the motor to supply the free line-limbic process of movement of the unbalance unpredictably long and not to overheat at the same time, the following condition must be fulfilled: when the starting (or the stopping moment is raising, its maximum value must not exceed the nominal (passport) electric motor's moment. The further way to raise the

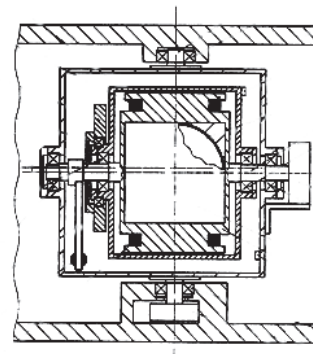

Fig.3

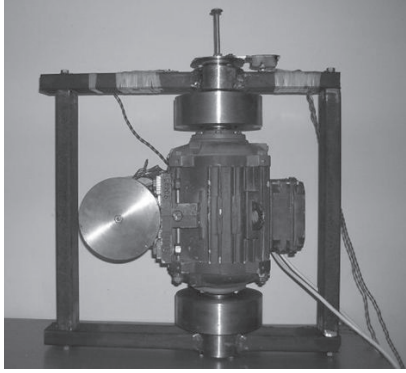

Fig.4

inertor's efficiency lays in direction of using of the molecular and even nuclear fluctuations of the substance. In the above mentioned numeric example if we keep the same mass dimensional parameters of the inertor and its power, and lower only the radius of the unbalancing mass fluctuations, for example, to a value close to 10 m (we assure the reader that this is far from the limit...), then the motor's drive power raises dramatically (in ten times!). There is a foundation to propose that inertor's action principles are in real an universal natural mechanism, in part in transformation of the space's (vacuum) energy to bodies' kinetic energy. From this point of view can be explained from where an addition of energy in super single gaseous vortex and liquid heat generators appearing (look at [2], for example). As we see, the inertor is incomparably superior to the any engine or motor in efficiency. It allows performing, for example, flights to any point of our planet in split minutes and with the complete absence of discomfort in a way of high gravitation and weightlessness. Any man would want to have such a vehicle in his own use. We assume that already throughout this century it will be used as the main drive for all vehicles and energy machines.

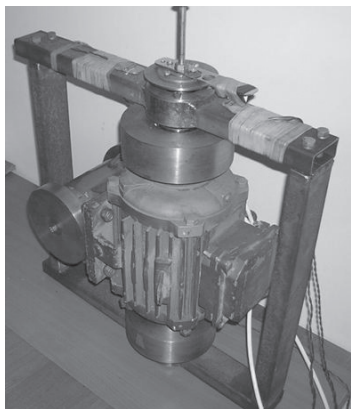

Fig.5

References

1. Azukovskii V.A., Zigunenko S.N From where the either wind blows?// Znak voprosa.-1993.-N1-2, pages 64-83
2. RF patent N2045715/Potapov U.S.//Inventions bellutin , 1995 – N28\
3. Shipov G.I. "The physical vacuum theory – Moscow, NT-Center publishings,1993
4. The horisonts of sciences and technologies of the 21 centuri. A collection of of works undes edition of the academic RAEN Akimov A.E. The works volume 1, Moscow, 2000
5. Chernyaev A.F. The inertion – cooperation motion. Moscow, 1992
6. Linevich E.I. The dynamic symmetry of the universe. "Nature and abnormal phenomenons", N1-2, 1995, page 6.
7. Linevich E.I. The gravitational engine. RF patent N2089487.
8. Fominskii L.P. The cannon shot with a osehka at the "eternal engine" inventors//Elektrik.-2003 N3, pages 21-22, N4, pages 20-23.
9. "let's make our own UFOs!"/The technics and science, N6, 1989, page 48
10. Linevich E.I. The phenomenon of antigravitation of the physical bodies/YAFT/, Khabarovsk, PKP "Mart", 1991, page 20c
11. Linevich E.I The geometrical explanation of the Hasaka-Takeuchi with rotating rotors. The report on the 2nd SIS International conference "The union theory of the world and its practical use ", 20-21 of september 1993, Petrozavodsk, Russia
12. Hayasaka, Takeuchi S.//Phys.Rev.lett, 189, V.63, p.2201-2704
13. 13 Forward R.L. Journal of propulsion and Power, 1989, N1, p.28-37.
14. Tukanov A.S. The vector drive engine// "New energetics", N4, 2003, page 13
15. Senkevich V.E. The inertial motor// "New Energetics", N2,2003, page 49
16. Linevich E.I About technical possibility of the time's rhythm management//Graviton N8, 2002, page 10-11
17. Linevich E.I. Physics of the UFO-effects//Gravito N1, 2003, page 10-11, N2, 2003, page 10-11
18. Makhuhin S.S The mechanics unknown qualities//Graviton N7, 2001, page 3, 9.
19. Linevich E.I. The absolute zero- this is hot!//Graviton, N9, 2001, page 8-9.
20. Linevich E.I. The globe in a role of the power drive of an electrostation//Graviton, N2, 2004, page 10-11
21. Anistratenko L.A. Gravitation and UFO: one simple answer to hundreds of not simple questions. "Yantarnui skaz", 2003.
22. Kish kintsev V.A. Galilean Electrodynamics, 1993, V.4, N3, p.47-50
23. Sirl-effect-generator//Raum & Zeit"/Germany/1989 #39-40, 42
24. Linevich E.I. The device for cargo transportation A.c. USSR N644706, 16.09.1976/
25. Linevich E.I. The wheight lifting device A.c. USSR N650977.24.01.1977
26. Karyakin N.I Bystrov K.N., Kireev P.S. The short encyclopedia on physics. "Vyschaya shkola", Moscow, 1964.
27. Linevich E.I. "The antigravitation device, The 2nd All Unions symposium materials "The renovation of the natural science"/Moscow-Volgodonsk,1991/
28. The polytechnical dictionary, edited by I.I. Artoblevskii, Moscow, "the Soviet Encyclopedia", 1977.
29. Linevich E.I., Ezhov A.F. The inertial motor-engine. Patent's application: N2002134855, 23.12.2002, international application: PCT/RU 2003/000572, 22.12.2003.
30. Our days physics. A collection of works, Moscow, "Znanie", 1972
31. Ginzburg V.L On relativity theory, A collection of articles, Moscow, Nauka,1979

Device for energy transformation

Russian Federation Patent claim of Nov. 25, 1992
The Author: Vladimir I. Kovalenko

Similar USA Patent # 3857242 of 1974

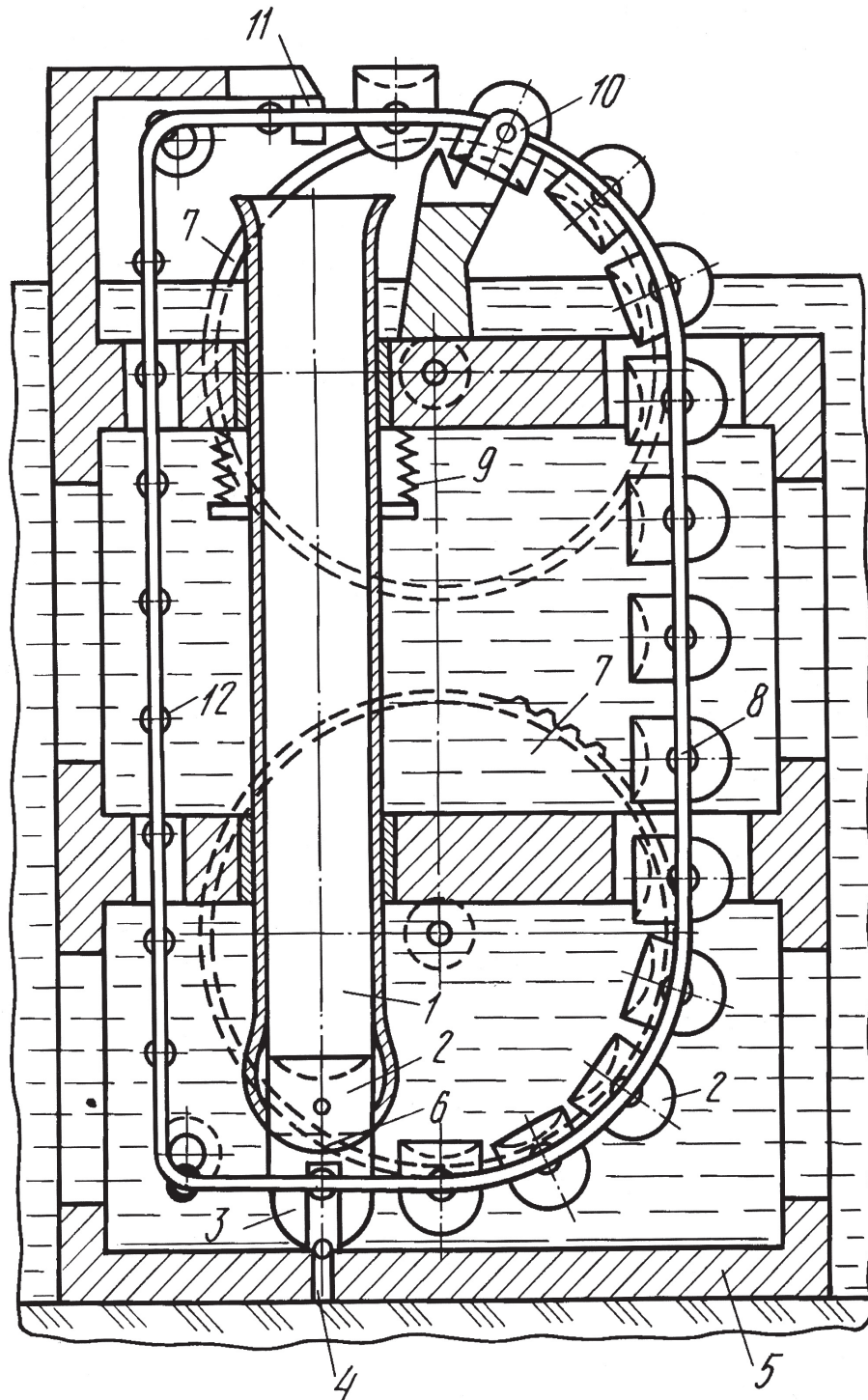

The planet Earth is a natural electrical motor-generator

V.D. Dudyshev
Samara, Russia
ecolog@samaramail.ru

The Nature is our wise Teacher

In order to learn how to get pure electrical power, firstly we need to understand how our Planet produce it. The answer to an enigma of natural geo-electricity is a key for the progress of new energy technologies. This article is result of theoretical and experimental researches on electrical and mechanical solar energy conversion by our Planet on physical models and ways for its practical application are given.

Why are our Planet and some of its media rotating ? Only recently the scientists have found the right answers to these eternal questions. It is known for a long time that the Earth is a natural electric magnet in a form of magnetic dipole with magnetic poles which are almost opposite to the terrestrial poles. The Earth also possesses its proper electric charge and electrical field. The circular currents were detected for a long time ago in different media of the planet and in its subsoil and in the Ocean and atmosphere. However the conclusion , paradoxical as it is, that our Planet is exactly natural electric machine which makes our Planet rotating , was made only recently. As far back as 1984 for the first time in the world I put forward and this established scientifically hypothesis about the reasons of the Planet's rotation. [1]. According to my theory the Earth is a natural inductive-capacitive electric machine being simultaneously both motor and generator. This conclusion was made in my article [1]. The given theory establishes the electromechanical mechanism of the Planet's rotation and the unified electromechanical essence of all the phenomena of nature [1,2]. Particularly it results in the following: many natural disasters (earthquakes , volcanoes eruptions etc.) are the abnormal modes of the

given natural geo-electromechanical system connected with the changes of the solar activity [1]. However this phenomenological theory was rather deficient on its initial stage. Later in my articles [2,3] I demonstrated in more details the reasons and the mechanism of the geo-electricity arising and the ways to use its renewable energy in power engineering and in fuelless astronautics. Also the effective method to prevent many natural disasters by regulating electric charge of the Planet was proposed [3]. Further exploration of geo-electromechanics by the author and other scientists has been demonstrated that several interconnected natural electrical machines being natural electrical motor-generators function simultaneously on our Planet and in its circumterrestrial space [3-7].

Types of natural electric machines of our Planet and their interconnections

They are listed below in decreasing order:

1. The circumterrestrial magneto-hydrodynamic generator (further- MHD generator) converting the energy of the solar plasma flow and the Earth magnetic field (EMF) into natural electricity.
2. The circumterrestrial MHD generator which makes the ionized atmosphere rotating.
3. The planetary electrostatic natural high voltage motor-generator which operates based on principle of the electro-dynamic induction and interaction of the ionosphere electric potential with the current-conducting spheres and circular currents of the Planet.
4. The planetary unipolar electromagnetic Faraday motor-generator.

5. The oceanic and underground magnetohydrodynamic generators-engines which create bias of moving charges and displace masses of natural water electrolyte in a form of ocean currents and the melt current-conducting rocks inside of the Earth.

The operation of all these electric machines located in different geospheres of the Earth is self-regulated and interrelated.

The hierarchy of levels of this power system and the interrelation of its different stages of conversion of solar energy into planet rotation kinetic energy is briefly described below.

Where from, why and how does the natural electricity arise?

As it is known from electrical physics the origin of the electromotive force is provided with such physical effects as electromagnetic and electrodynamic induction, Hall effect and some others [5, 8]. The solar wind is the main supplier of natural electricity of the Planet. The circumterrestrial natural MHD generator [3] initially converts it into electric and magnetic field of the Planet. In fact it converts the whole flow of solar plasma via Hall effect and EMF into potential difference and natural circumterrestrial geoelectricity by sorting and deflecting opposite charges of the solar plasma in the limits of the Planet magnetosphere. Also the ionospheric plasma contributes to this process. As a result the electric charge and electric field of the Planet arise.

a) Unipolar electromagnetic motor –generator of the Planet.

As far back as 1831 the phenomenon of the unipolar electromagnetic induction was discovered by Faraday [8]. Besides he proposed the first unipolar motor and generator separately at different times [8]. However Faraday did not examine their combined operation much less in combination with electrostatic motor-generator. It is known that the operation of the unipolar electric generator is based on the phenomenon of unipolar electromagnetic induction. For its creation it is required to have relative displacement of magnetic lines of force relatively to its current -conducting media. Does such mutual displacement exist on our beautiful Planet? The information accumulated by natural science and other sciences prove that the axis of

geomagnetic dipole is fixed while the Planet is rotating around its axis during 24 hours.

Hence the currents from unipolar induction must be induced. Let's consider the physical nature of this process in more details. Because of the Planet orbital rotation the magnetic lines of force intersect its surface and all its current-conducting media. As a result the unipolar electromagnetic induction create electromotive forces (emf) in current-conducting media of the Planet (in the ionized upper atmosphere, seas, subsoil). That is why the unipolar induction emf is generated and circular currents induced by this emf are flowing in these current-conductive media of the Planet including its melt core. They also intensify and support The Earth magnetic field i.e. the Earth in fact represents original natural electrical self-excited unipolar Faraday generator. Note that the unipolar electeromagnetic Earth generator induces additional natural potential difference along its meridians between magnetic poles and magnetic equator of the Planet with total voltage about 250 –400 kV. The operational mode of this natural planetary unipolar generator differ even during 24 hours, because the circumterrestrial magnetic field of the Planet in illuminated zone of the orbit and in shadow differ a little. As it is known the Earth magnetosphere is collapsed by solar plasma pressure in illuminated zone and extended by solar wind in shadow of the axes rotation orbit, i.e. it is rather non-uniform even in the same latitude and while moving away from Planet it is being intensified and it influences considerably on the operation of natural electric generators. Created by electromagnetic induction the currents are flowing all over the Planet and involves electromagnetic force and torque of the Planet.

b) Magnetohydrodynamic motor-generator of the Planet

The interaction of the induced circular circumterrestrial currents in the natural electrolith –waters of the World Ocean with the lines of force of the Earth geomagnetic field create Lorentz force in them and as a result the effect of magnetohydrodynamic engine arises. Exactly this natural planetary MHD generator creates strong global currents-circulations of the natural electrolith in the Ocean, as well as global circulation of the upper ionized atmosphere and certain processes in the Planet core. Formed by

this unipolar induction the total induced current of all Planet media via its interaction with EGMF creates electromechanical torque of the Planet and its separate current-conducting media which coincides with the direction of the Planet rotation and oceanic currents [1, 2, 3, 4].

c) Natural electrostatic motor-generator of the Planet

The electrodynamic induction was discovered in Russia in 2000 [5]. The core of the phenomenon is that the emf arises in the conductor due to change in electrical induction flow as a result of mutual displacement of the conductor and the source of the external electric field. Earlier I proposed and patented this principle in motor-generators with rotating electric field for getting electrical power and mechanical torque [6, 7].

The discovered phenomenon also takes place on the Earth because there are both external electric field in a form of ionosphere total charge and natural conductors of the current-conducting planet spheres. As a result of electrodynamic induction the natural electricity is generated and transformed to all current-conducting planet spheres and particularly the charging of the planet underground capacitors [1]. Then it creates strong circular current in ionosphere and other current-conducting atmospheres with the help of electrodynamic induction [5]. This current creates total magnetic field of the Planet. With the help of the electrodynamic induction the ionosphere electrical charge and the energy of the Planet fields are transformed in a form of induced emf and electric power of the capacitive currents inside the Earth. As a result the electrical charging of all surface and underground natural electric capacitors take place. [1].

The electrostatic planetary generator with the help of its electromotive forces (emf) calls forth induced circular currents in all current-conducting planet spheres. The interaction of these circular currents with the planet electric field calls forth its electromechanical torque of the electrostatic planetary engine which partly provides propulsion mode of the planet. When the solar activity changes also its voltage changes and hence the electromechanical torque of the electrostatic engine changes. The modes of this combined natural electric machine are changeable ones both in short-term 24-hours cycle and in

year-term and longer cycles. It happens because the parameters of the planet magnetic and electric fields also differ depending on the planet position on its ellipse-shaped orbit relative to Sun and on the planet activity. It becomes understandable completely because the flow of the solar plasma passing through the planet magnetosphere changes depending on these parameters. It involves different dynamic processes and changing of torque, voltage and power of this natural unipolar motor-generator – the Earth. The periodic changes of the planet magnetic field, its orbital rate during periods of solar activity and different geologic epochs were already recorded by scientists for a long time ago [1].

As part of the proposed theory of the electromechanical energy conversion by planet this dependance of the natural unipolar motor-generator rate on emf and torque values is logic and rather understandable.

In full conformity with the theory of unipolar electrical engines it is possible to affirm with assurance that during the process of geomagnetic field inversion which has already begun the geomagnetic field will be further weakening and it will result in deceleration of 24-hours rotation of the Planet and further direction reversing of the Planet rotation. Since the multiple inversion of the EMF has already been proved by geophysics, the Planet during its existance changed several times the direction of the axis rotation because of the reversing of the Earth Magnetic field (EMF).

Summary

So, the axis rotation of the planet is provided with two electromechanical torques (the electromagnetic and electrostatic one, and their action is tangent and interactive. Due to Lorentz force and effect of MHD engine there is a totality of interconnected phenomena of the atmosphere and oceanic waters etc. shifting and global cycling).

Conclusion

So, the Earth –is a unique natural electric machine which makes the Planet rotating and provides all the natural phenomena. As for the structure and operational mode it represents the combined natural electric inductive-capacitive motor-generator. The solar wind is its initial source of

energy and the dynamics of the solar activity influences considerably on its operation.

METHOD OF PHYSICAL SIMULATING OF GEOELECTROMECHANICAL PHENOMENA

In order to prove that the given theory of geoelectromechanics is true the experimental investigation of these natural phenomena using the method of physical simulation with the help of simple physical models was conducted with further comparison of the experimental results and accumulated by natural sciences already known geophysical facts.

PHYSICAL MODELS, EXPERIMENTAL PLANTS AND EXPERIMENTS

Several simple experimental plants simulating the combined electrostatic and unipolar electromagnetic motor-generator of the Earth in a simplified way have been developed, mounted and tested during operation. The information about their structure and experimental results is given below.

a) Simplest physical model of the unipolar Earth generator

The modernized plant of the simple unipolar electromagnetic Faraday generator (Fig.1) was assembled in order to prove in experimental way that the effect of unipolar induction arises from EMF provided that the Earth magnetic field is fixed in space relative to the rotating planet.

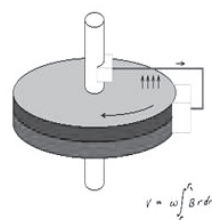

Fig. 1

It consists of the ring-shaped permanent magnet with axial magnetization (magnet poles are indicated with colour), which simulates magnetic

dipole of the Earth; non-magnetic, for example, copper disk simulating current-conducting media of the Planet located above the ring-shaped magnet and device for forced axial rotation of this magnet-disc couple (not shown), the device for brush-type current collection with electrical connection of rotation axis and disc face. The milliammeter has been inserted between two current collection brushes into the gap of connecting conductor (not shown). The experiments have been carried out for examining the unipolar motor-generator of the Planet. Particularly for finding out what conditions are required for unipolar induction arising. The first experiment represented the axial rotation of only magnet on fixed disk. The unipolar induction has not arisen and there was no current in circuit between brushes. Experiment 2 consisted in combined synchronous axial rotation of the magnet and disk. Emf of unipolar induction has arisen and the milliammeter has indicated the current of certain direction.

Experiment 3 consisted in rotation of the current –conducting disk relative to fixed magnet. The results of measurements are the same as in experiment 2. Then all these 3 experiments have been repeated many times at different angles of inclination of magnetic axes relative to axes of disk rotation. It was found out that when the position of magnet was inverse one (its turning was 180 degrees) the values of emf and current from disc were the same as in experiments 2 and 3 but the direction was opposite one. The results of experiments while having different other angles of rotation axis and magnetic one have shown that while increasing this angle within range from 0 to 90 degrees the values of emf in the current-conducting circuit were being decreased and when the shift angle was equal 90 degrees they were equal 0.

The conclusions concerning experiments with the simplest physical model of the Earth unipolar geomagnetic machine are the following ones (Fig.1):

1. When the magnet rotation is axial one its lines of force are fixed in space.
2. When increasing the shift angle of disk and magnet rotation axes from 0 to 90 degrees the emf value of the unipolar induction is being decreased. When further turning from 90 to 180 degrees it is again being increased but it has opposite sign.

3. From the experiments on the first model it is possible to make conclusion that the inversion of the Planet geomagnetic field will result in changing of emf polarity and direction of its axial rotation.

b) Universal physical model of the natural electric motor-generator of the Planet

In order to study operational modes of this unusual natural electric machine of the Planet its refined physical model has been developed and investigated. On Fig.2 the physical model of the combined electrical inductive-capacitive machine of the Earth in a form of experimental plant is shown on Fig.2. The components' designations of this physical model are given below. It consists of the unipolar magneto-electrical machine and the electrostatic machine combined with it structurally. Further the description of structures and operational modes of each of these machines are given.

Physical model of the unipolar motor-generator of the Earth

The following components have been used in this model: the composite magnetized ferromagnetic ball 7, located over the dielectric carrier ball 1 with the magnetic axes being regulated by inclination angle relative to rotation axis 8 and several non-magnetic disks 6, located in parallel with the ball equator 1.

several ring-shaped magnets of different diameter and thickness (they are not indicated on Fig.2). They are connected with opposite poles in magnetic ball with the help of several current-conducting non-magnetic disks 6 made of materials with different electric conduction, inserted between these magnets, simulating different current conducting planet spheres. On Fig. 2 only one disk is shown for simplification. The physical model of the unipolar machine is added with brush mechanism for current collection (10,12,13, 14) and devices for measuring emf and electric power 17, 18. It includes also suspension 24, drive motor 9 with the regulated low voltage source 11. The lateral surfaces of ring-shaped magnets 7 are covered with copper rings 15. Also the separate conductor 16 with weight 5 in a form of light bulb is located in parallel with the ball equator. It simulates the generating device for artificial getting of electrical power with the help of planet rotation energy using unipolar method. For realizing the unipolar engine mode the voltage from unit 11 is supplied via carbon brush 10 to rotation axis 8 and separate disks 6 via brush contacts 10, 14, switch 12 and commutator 13. For operation in mode of unipolar generator the switch 12 should be off and the ball 1 is rotated with the help of axis 8 from drive motor 9 by supplying power from voltage regulator 11 connected via switch 19. When investigating mode of electrostatic motor-generator switches 12, 19 are open.

Fig.2

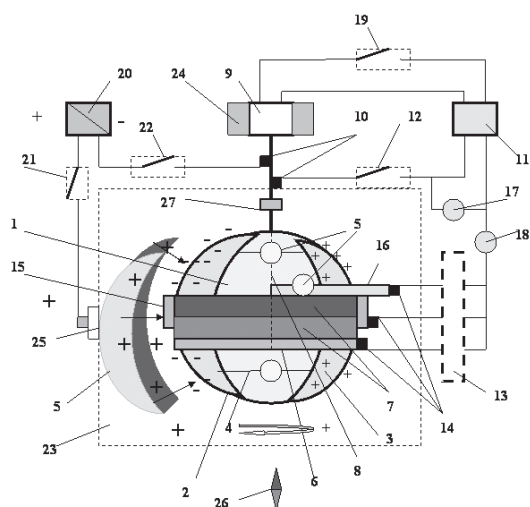

The composite spherical magnet is made of

Physical model of natural electrostatic motor-generator of the Planet

It comprises the following units and components of the experimental plant (Fig.2): dielectric ball 1 with current-conducting segments 2, 3, connected via electrical conductors 4 with light bulbs 5, located in parallel with ball 1 equator. The positive high voltage potential (20 – 30 kV) is connected to segment 5 via switch 21 from regulated high voltage source 20 and the negative potential of this source is connected via switch 22 and brush 10 to rotation axis 8 of ball 1. The external current-conducting arc segment 5 simulates zone of ionosphere electrical charge and space between internal edge of segment 5 and ball – the Earth electric field and circumterrestrial electrical capacitor, formed between segment 5

and ball segments 2, 3. The electrical parameters are registered by devices and oscillograph. In generator mode the described electrostatic machine is driven by ball 1 rotation through rotation axis 8 from above mentioned drive motor 9. In this mode the electrical potential is supplied only to segment 5. For realization of electrostatic propulsion mode the high voltage from source 20 is supplied both to segment 5 and rotation axis 8 or to the ball itself via brush 10. Change of direction of magnetic field is registered by compass 26 and shaft 6 rpm – by tachometer 27.

COMBINED OPERATIONAL MODE OF EXPERIMENTAL PLANT

The physical model permits to realize combined operational modes of this combined electrical machine. Particularly, simultaneous operational mode of electrostatic motor-generator or combination of generator mode of electrostatic machine and propulsion mode of unipolar machine etc.

PRINCIPAL RESULTS OF EXPERIMENTAL INVESTIGATION ON FULL PHYSICAL MODEL (FIG. 2)

All these separate and combined modes of this combined electrical machine have been investigated on a given physical mode.

The experiments have shown the following:

1. Real existence and possibility to realize effects of unipolar and electrodynamic induction in physical model of the Earth electric machine as well as arising of electromotive forces from given inductions and circular currents in discs and ball.
2. This combined electric machine is able to operate in engine and generator modes both simultaneously and separately.
3. The magnetic field of rotating ball 1 of given design can be created only from ball rotation by inducing emf and arising of circular current along the ball equator from external electrical field of segment 8 (in this experiment the magnets were removed from ball 1).
4. The direct dependence of combined engines rpm on applied voltage values was revealed.
5. The direct dependence of generator voltage

on angular velocity and intensity value of external magnetic and electrical fields was revealed.

6. The effect of electrodynamic induction emf and induced current arising in artificial current circuits with load (4,16) when rotating ball 1 was revealed.

METHOD FOR DERIVING AND CONVERTING THE EARTH ROTATION ENERGY AND ENERGY OF ITS ELECTROMAGNETIC FIELD INTO USEFUL ENERGY.

How is it possible to use effectively this planet enormous and renewable energy and natural processes of natural electricity generation on the planet for producing cheap electric power? While understanding more completely the geomagnetic electromechanical effects on the planet and planet generation of natural electricity and in connection with power and ecology problems of our civilization this scientific-practical task is being become question of present interest.

Alternative circuit geomagnetic electrical power engineering

Since the magnetic and electric fields of the planet are fixed in space and the planet surface is rotating relative to geomagnetic and geoelectric lines of force, the unipolar and electrodynamic emf is being induced in all current-conducting circuits of the planet which intersect geomagnetic lines of power.

It is rather understandable that in any artificial current -conducting conductor and circuit the unipolar emf will be also induced. Its value depends on the conductor length, the geomagnetic field parameters in place of its location and position of the conductor relative to the geomagnetic lines of force. The estimation has been shown that in conductor 1km length oriented in the direction west-east the unipolar emf from EGMF will be equal several tens of volts independently on the latitude. In such closed circuit consisting of two conductors 100km length and minimal internal resistance located perpendicularly to the geomagnetic lines of force with magnetic shielding of the second parallel conductor the power being generated will be tens of mVt. The

principle of functioning of such alternative power engineering is already rather clear and consists in inducing of unipolar induction from EGMF in any artificial current-conducting circuit which intersects geomagnetic lines of force. For the first time the author has proposed to use this principle of getting electric power from geounipolar induction with the help of closed, partially magneto-insulated current-conductive circuit on the orbital fuel-less power plant. [3]. However for our civilization it is more important for the present the task of creation of the above-ground circuit geomagnetic power engineering. Two conditions should be provided for practical realization of such non-traditional above-ground circuit power engineering:

1. Right orientation of these generator circuits in middle latitude: perpendicularly to the geomagnetic lines of force and corresponding devices.
2. Magnetic shielding of the return conductor of this closed circuit in order to exclude the inducing of emf from EGMF in it.

If both conditions are provided it is rather real to get electric power by electromechanical conversion of enormous kinetic energy of the planet rotation with the help of electromagnetic induction.

For this purpose it is necessary to place this partially shielded double current circuit perpendicularly to the geomagnetic lines of force, i.e. the plane of this circuit should be oriented in the direction east-west because the geomagnetic lines of force in middle latitudes come in fact approximately in parallel with the Planet surface.

Versions of geomagnetic circuits and their location on the planet

These artificial generator current-conductive circuits can have different dimensions and designs. For example, they can be made in a form of hollow metallic pipes filled with water and in this case due to electro-thermal heating of these pipes by induced inductive currents it is possible to get simultaneously thermal energy, hot water and vapor. The electric power regulation is carried out by changing resistance of loads, connected to these circuits or angle of circuit

turning. The electric power transmission lines and even trunk pipelines can be useful as devices of circuit geomagnetic power engineering especially during period of their integration and execution. The designing, planning and manufacturing of such unusual and simple circuit geomagnetic power plants will not involve great difficulties because all principal parameters of geomagnetic fields and planet itself are known for a long time and there is a certain experience accumulated for designing of the unipolar electrical machines.

Outlook and ultimate power of circuit geomagnetic power engineering

Since the kinetic energy of the Planet rotation is more by many billion times than the total electric power generated by civilization, the total power of such circuit geomagnetic power engineering could be enormous.

That is why in future such circuit geo-electrical power engineering can cover basically all current needs of civilization in power without any threat to decelerate considerably the axial rotation of the Planet. It is possible to intensify the effect of natural generation of electric power in artificial circuits by placing them inside zones of planet magnetic anomaly.

General conclusions

1. The Earth is a natural electrical machine. It represents combined as for its design and operational modes natural electromechanical inductive-capacitive motor-generator driven from energy of the solar plasma.
2. The powerful flow of solar plasma is the primary source of the electric power. Initially it is being converted into electrical power by circumterrestrial MHD-generator. The electrostatic generator of the planet makes additional considerable contribution into natural electricity. All these natural geo-electric generators have property to combine their spatial designs and operational modes.
3. Our planet is being rotated by natural electromechanical torque created by torques of its unipolar geomagnetic machine and electrostatic machine. The action of these torques is coordinated and tangent relative to

separate media and to the planet surface itself.

4. The hierarchy and operational interactions of the natural electrical motor-generators of the planet were revealed.
5. The simplified, adequate physical models of the natural electrical machine of the planet and functioning of the given geo-electromechanical system were created and investigated.
6. Using simple physical models of the unipolar machines the effect of immobility of the geomagnetic lines of force and their intersection of media of this natural unipolar planet electrical machine was confirmed experimentally.
7. Using experiments on physical models the effect of unipolar and electric-dynamic induction on planet and generation with the help of their natural electricity in different current-conductive media, i.e. generator operational mode of the electrical machine of the Earth was confirmed experimentally.
8. Using physical models the effect of electric-dynamic induction in different current-conductive mediums of the planet and operational mode of exactly planetary electrostatic motor-generator were experimentally confirmed and investigated.
9. Using physical models the effect of planetary magnetism formed from electric-dynamic induction in its external electrostatic field with creation of circular geo-electric current was experimentally revealed and

investigated.

10. In the experiments the combined motor-generator mode of given inductive-capacitive machine was realized.
11. The methods for taking and electromechanical conversion of rotation kinetic energy and planet electromagnetic fields in order to get pure and cheap electrical power in above-ground power plants for satisfying needs of civilization were proposed.
12. The means and simple devices for getting electric power from planet fields and its natural electricity were proposed for realization of this method.

References

1. V.D.Dudyshev "The Earth – electrical machine", "Teknikamolodyozhi" №11/84.
2. V.D.Dudyshev "Introduction to global ecology or Electromechanics of alive nature", "Ecology and industry of Russia", №11/99.
3. V.D.Dudyshev . New Fuelles Spage Pover Engineering, New Energy Technologies, November-Dec.2002.
4. I.P.Kopilov. Space electromechanics, Moscow, MEI, 1998.
5. D.A. Dyudkin and A.A.Komarov "Phenomenon of current excitation in the conductor moving inside electrostatic field". Scientific discovery №149 –Scientific discoveries (Brief descriptions, 2000) // International Academy of the authors of scientific discoveries and inventions, Moscow, 2001.
6. V.D.Dudyshev. Latent Potential Energy of Electrical field, New Energy Technologies, July 2003.
7. V.D.Dudyshev. Method of electromechanical energy conversion, Patent RF № 2182398.
8. BES, M., 1991, p.526, 600.
9. Space physics –reference book, Moscow, 1986, p.636-640.

METHOD FOR PRODUCING HYDROGEN AND OXIGEN FROM WATER

Viktor G. Ermakov, Patent date 27.04.1998
Mozirskaya str. 5-70, Perm, Russia, 614037

The invention is intended for power engineering and can be used for getting cheap and economy energy sources. In open-ended space the over- heated water vapor at temperature 500-550 degrees is produced. The over-heated vapor is passed through high-voltage electric field (6000V) and hydrogen and oxigen are produced. The method is simple, economy, fire safe, high capacity one.

Editorial comments: In this case there are no conductivity currents, so the input power is minimal, it is required only to create electric field which will provide the very effective operation of this system .

Inertial device-generator

The author: Vladimir A. Gilchuk

2-nd per. Babushkina, 10, Ivanovo, Russia, 153031

Russian Federation Patent claim #2003136471 of 16/12/2003

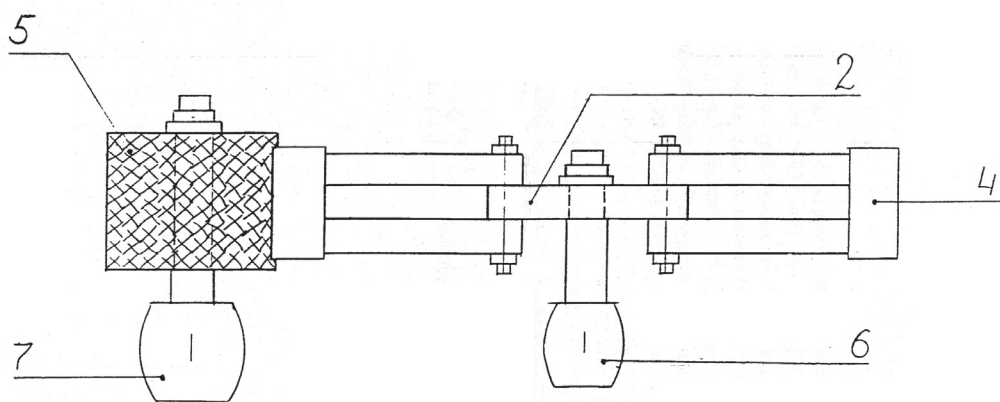
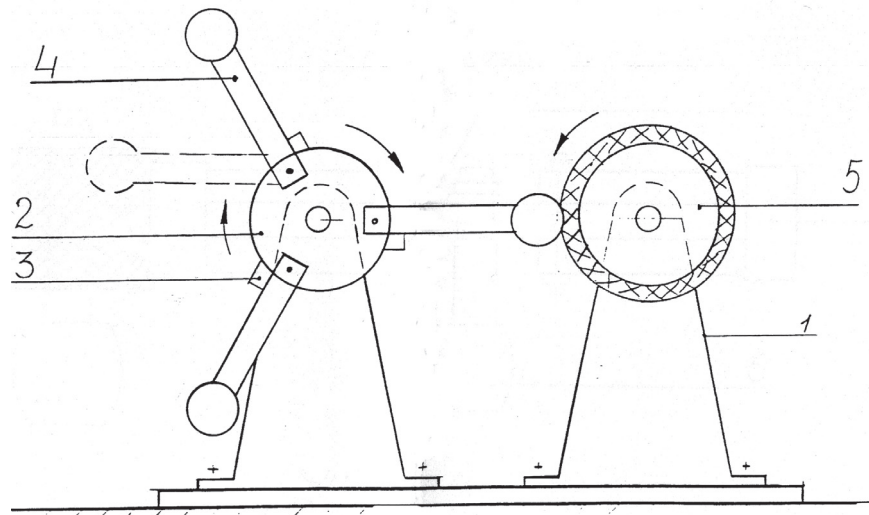

The aim of the invention: to build an electric station and device for other useful work.

On two steps 1, which have a possibility of a free spinning, installed a fly-wheel with an axle. Around the fly-wheel 2 circle supports 3 are secured. On the fly-wheel 2 hammers 4 are mounted. The wheel 5 is covered with rubber. The electric motor is connected to the fly-wheel 2 axel. During the rotation of the wheel 2 hammers 4 straighten in a radial line and hit the wheel 5, which is covered with rubber. At this, the hammers' weight is increasing in many times due to the inertial properties of the mass. That is why the power on the wheel 5 axel is many times more, than the power, spent on the fly-wheel's rotation. The electric generator 7 in part supplies with its energy the electric motor 6 of the fly-wheel 2. The output energy of the electric generator 7 is used for the useful work.

Chemo-electrical gravitational electrolysis by V. Studennikov

A possibility of a straight transformation of the heat energy to electricity

Makarov Andrei Fadeevich

The senior science associate of the laboratory of safe explosive works at NC VostNII.

Phone: (384-2) – 64-25-85, vostnii@kemnet.ru

Phone: (384-2) -64-05-45.

Russia, 650000002, Kemerovo, 2nd Tulskaa per., 5-5.

The article was prepared with the information support of engineer V.P. Lesov.

Saint-Petersburg, valery.lesov@petroscan.ru

Annotation: ideas on possibility of creating a thermal electronic pump for the straight transformation of the low potential heat and spreaded energy to the electric power are being observed here.

Is a utilization of free energy of the environment, the absolute temperature of which is about 300K (0C=273K), possible? In thermodynamics, there is no prohibition on “eternal engines”, working on the environment’s account. For example, thermal EDS appears in transistors’ thermal pairs only at the natural gradient of temperatures in the environment. In thermal pumps’ work cycles the “spreaded” low potential heat energy is used. The photo electronic emission happens at the electromagnetic radiation of the visible and IR-specters expense. The photosynthesis process, happening even in the dark, is natural too. Finally, the electric hydrogen generator (EHG) of Studennikov, transforming “free” energy of heat to the water (H₂O) dialysis process on hydrogen H₂, oxygen O₂ and electric power, is known [1]. The cycle of heat transformation to electric chemical energy forms is based on gravitational separation of heavy and light ions in the fast spinning dilution of electrolyte. For example, in the water dilution of bromious acid (HBrO₃) the formatting ions’ H⁺/BrO₃⁻ mass proportion is 1/128 (not counting the solvation skins). At a high enough informational “overload” in the spinning reactor-centrifuge the heavy negative ions BrO₃⁻ will be throwing away (“drown”) to periphery, and light protons H⁺ will be pushed out (“float up”) to the rotation’s axle. Furthermore, when reaching the reactor’s walls (BrO₃⁻) or its central axis (H⁺), the corresponding ions discharge, giving away to the corresponding electrodes its load, which is going further to the external chain, and extracting

“electrolysis” gases – H₂ and O₂ at the central and peripheral electrodes by a scheme: H⁺+H⁺= H₂-2e⁻; and BrO₃⁻+BrO₃⁻=Br₂O₃+(1/2)O₂+2e⁻; Br₂O₃+H₂O=2HBrO₃. The transferred environment heat compensates the electric chemical work of the water gravitolysis reactor-centrifuge. So, in the EHG cycle the water-solvent, and hydrogen, oxygen and electric power are extracted. – only at the heat spreading account. Only a small part of the generated energy is spend on the reactor centrifuge’s rotation drive, mostly on compensation of the friction forces in the bearings. The water’s presence in the electric transfer leads to its electrochemical disintegration, which requires not less than 3200 kkal/kg of the supplied heat, limits the working diapason of negative temperatures, it is necessary to dilute the electrolyte, “electrolysis” gases’ separation and extortion from the reactor (2H₂+O₂). But let’s look at the closed scheme of electric transfer in non-water self ionized electrolytes. Let the ions’ discharge happens with a transformation of the charge carriers into original substances and a full cycle reconnection in reactor’s volume. Theoretically, gravitolysis is possible in the condensed, gaseous or plasma phases. However, the ionization in gaseous and plasma phases, usually, is possible only at a high enough temperature (from approximately 10000K, which is much higher than of the heat equilibrium of the environment (about 300K). At the same time some of the metal dilutions in liquid ammonium are known, with almost cryogenic temperature of the ionization and freezing of metal-ammonium eutectics (approximately 90-160K) – at the expense of the metals and free electrons’ ions solvation with the solvent-ammonium molecules (some of the atoms stay in a dissociated condition) according the schemes [2]:

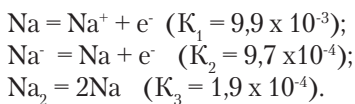

The diluted solutions of metals in ammonium have usual blue coloring, and the concentrated solutions have a copper-bronze one. The solvent-ammonium steam's pressure is decreases considerably, and the ammonium solution's thickness is on a level lower than of the water electrolytes. In ammonium also dissolve sour grounded metals, Al, Eu, Yb, some intermetallides (Na_4Pb_9 [2]) and others. In absence of oxygen and light solvateited electrons can stay in the solutions for months. It is experimentally established that a solvataited "floating" electron with the rest mass of $m_e = 9,1 \times 10^{-31} \text{kg}$ in metal-ammonium solutions creates an empty space around itself with a radius that equals around 0,33 nm (a volume V, around $1,5 \times 10^{-28} \text{m}^3$) [2]. Therefore, the microscopic density of "electronic gas" in solution would accord to: $\rho_{e^-} = m_e / V_e = 9,1 \times 10^{-31} \text{kg} / 1,5 \times 10^{-28} \text{m}^3 = 6 \times 10^{-3} \text{kg/m}^3$ (i.e. around 6 g/m^3), which is about in 12 times less than the liquid hydrogen's density and in 5 times lighter than air. At the same time the free electron e (but not the solvated one (NH_3)) is an elemental particle with the wave length of DeBroigle $\lambda = h / m_e v$, that is for $T = 300 \text{K}$ about $\lambda = 6,63 \times 10^{-34} / (9,1 \times 10^{-31} \times 10^3) = 0,7 \times 10^{-6} \text{m}$ (700nm), but at the same time the clasiscal electron radius is only $r_e = e^2 / m_e c^2 = 2,8 \times 10^{-15} \text{m}$.

The resulting cooperation of all quant-chemical factors leads in experiments, however, only to comparably small decrease in ammonium+metal compound's density. It is seen from the Table 1 that for the 9,25% solution of lithium the density decreases only in 1,4 times (from $0,682 \text{ g/cm}^3$ – for ammonium to $0,49 \text{ g/cm}^3$ - for the solution).

The metal dissociation incompleteness, electrons cooperation into diamagnetic pairs, electronic and ion clusters formation and others resist to the

super high "inflation" of solutions with low density electrons.

According to the most satisfying models, electron in solution is not located, but "spreaded" around a big volume, which leads to the electron and orientation polarization of the surrounding molecules. An electron is being caught by the resulting field, and the pushing away forces between it and the solvent's molecules electrons leads to the low density "electronic sphere" [4]. Nevertheless, electrons, as physical objects with a non-zero resting mass, mute obey the common mechanics laws, in detail, "float up" under of an analog of Archimed's force's influence. The uppermost effect of the self dividing of the charges in the centrifugal "thermal electronic pump" (TEP) should be expected for the heavy metals: Rb, Cs, Eu, Yb, Pb, some charged complexes of metals and the others. By the work of TEP's cell on a rotation circle with a radius R (picture 1) heavy positive ions of a metal Me^+ , "stuck" by the centrifugal force to the end electrode, accept electrons from it and create neutral atoms, which are ionized by the solvent again ($\text{Me} \rightarrow \text{Me}^{++} + \text{e}^-$), and the light electrons – "float up to the opposite end – electrode and are consumed by it.

The collected charges' from electrodes outtake connects the electrical chain. The output power from each cell of TEP can not succeed the potential of ionization of metals in solution, i.e. approximately up to 2-3 V. A following connection of many cells on a common axis of rotation will let to gather enough EDS, and the electricity's

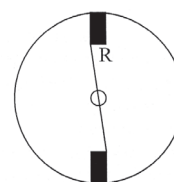

Fig. 1

Table 1. Properties of Some Solutions'in liquid ammonium [3]

	Li	Na	K	LiBH4
Dilution, g/100g NH3 at temperature (-33.3 C)	10,2	20,1	32,0	177 (room)
The temperature of freezing, C	-185	-110	-157	43
The boiling temperature, C	70	-	-	-
Density, g/cm ³	00,49	0,578	00,628	-
Steam pressure at -33.3 C, mm /merc.	3	400	-	-
Dilution heat, kkal/mol	-9,7	+6,9	+4,5	-19,2

quantity will be determined by the cells and electrodes' heat exchange with the environment's heat. In the case with the dilatible intermetal plumbumides of Na_4Pb_9 kind, a polarity of generator electrodes' change will happen at the diffusion of super dense polyatomic cubic [6] lead unions $[\text{Pb}^4\text{Pb}_8]$ to the peripheral anode and the light ions Na^+ , NH_4^+ clouds on the cathode. The portions' $\text{NH}_4^+ / [\text{Pb}_9]^{4-}$ masses correlation compiles 1/103.

Side effects

It is known that sheloch metals push out the hydrogen from ammonium with some time or at the canalization's presence in an analogy with water: $\text{Me}=\text{NH}_3=\text{MeNH}_2+0.5\text{H}_2$ ($K=3\times 10^{-9}$ [5]), to which a very small, but visible solvent's autoprotolysis furthers. For the hardly dissolving in ammonium lithium amides and for natrium LiNH_2 and NaNH_2 hydrogen's extraction appears to be an irreversible reaction. The ammonium's dissolving speed's raising with the electrically positive dilatible metal's growth, which is from lithium – to cesium. However, if for the light metals Li and Na this reaction is unturnable (the crystallization of LiNH_2 or NaNH_2 and leaving the reaction zone), then in case of the well dissolved amides K, Rb, Cs the corresponding reaction turns out to be reversible, the reaction constant number compiles $K=5\times 10^4$ [4,5]. A pressure growth of the highly dilatible in ammonium hydrogen will be helping to the reaction's reversibility too. So, to prepare the working electrolyte for the "ammonium" TEN is congenially by dilution not clean metals, but with an addition of their hybrids Me^+H^- and of the same type.

The other side reactions under the low working temperatures may be the scheme of the free ammonium $(\text{NH}_4)^0$ formation and its disintegration [5]. So, the hydride-ions H^- , having comparably long effective radius about 0.155 nm and approximately on three levels less density than the hydrated "naked" protons H^+ , become the competing negative charges' carriers in ammonium electrolyte in the same row with solvated electrons e^- . As we see, the electric transfer's closed cycle schemes are possible not only by solvated electrons and in an ammonium environment, but also in halogen –hydrogen, nitrogen-acidic, liquid SO_2 , Cl_2 , Br_2 and other connections, including complex, some eutectic salt melts, or even cryogenic F_2 , O_2 , H_2 . Perhaps, a schemes of the thermal electronic pumps with a solid

electrolyte, on the base of Pb, Ni, Pt, dissolving hydrogen with its ionization on elemental particles: electron e^- and proton p^+ . At this the dislocated electron is "solvated" in the conduciveness zone, and the moving "proton gas" H^+ is able to tunnel through the metal-solvent's fixated ion structure. The theoretical proportion of the charges' e^-/p^+ carriers masses in this case is 1/1836, which is on lever than in the water solutions.

As we see, at a low enough absolute temperature, when the thermal (mixing) ammonium molecules' or metal-solvent structure atoms' movement is small enough, some separation of the different mass ions may happen even in the gravitational Earth's field (1g) conditions, because the efficient density of the "electronic gas" at 5 or more levels lower than metal ions' density. In other words, at the fixated vertical pipe's with a metal-electronic solution ends a non-zero difference of electrical potentials must be observed. (!). According to metal's accumulation at the bottom end of the pipe, the discharging current will be decreasing, but a periodical pipe's turning "upside down" reanimates the "thermal-galvanic element" at 100%. The force of the floating up low density electrons in a solution in the external gravitational field is the "electronic pump's" driving force EDS, and "the friction forces" – the thermal (Brown's) particles' motion, the solution's thickness and the electrical resistance. The last mentioned factors will be seeking for zero at the superconducting ion systems. For the comparison: in an EVG reactor with a diameter 0.3 m with circle rotation speed of 52 m/sec the difference of the potentials on electrodes is about 0.03 V at the used ions $\text{H}^+/\text{BrO}_3^-$ masses' equilibrium of around 1/128 [1]. In ammonium solutions an electron's and metal ion's masses' equilibrium reaches: for kalium – 7.16×10^4 ; for rubidium – 1.57×10^5 ; for cesium – 2.44×10^5 , which is on three levels higher than the ion's $\text{H}^+/\text{BrO}_3^-$ masses equilibrium in the EVG electrolyte. An approximate calculation of the closed electric transfer cycle in ammonium solutions of rubidium and cesium gives an evaluation of the expected potentials' difference at the ends of every cell of 0.1 m high at about 0.8 V during the rotation around the circle with a radius of 0.5 m with speed about 200 m/sec. A follow-up connection of many spherical cells-reactors on one spindle will give away the necessary EDS, and in addition to that, the gathering electrical power is limited by the heat exchange's efficiency of (self cooling) cells and electrodes' surfaces with the environment's heat. It is sensible to incorporate the cells-reactors in the engine-propeller empty blades

and with an electric motor on a spindle. Let us note that in the given example the rotation frequency on the spindle will make about 60 revolutions per second (3600 min^{-1}), which stays on the “medium rotating” DVS level and on a level lower than the existing turbines and propeller engines’ rotation speed. With the use of the solutions of heavier elements from Mendeleev’s chart (lantanoids, actinoids), the collected tension at the cell’s ends will be raising, approximately, in proportion to the raise in atomic weight of the dissociated in liquid ammonium metal: $\text{Me}=\text{Me}^+=e^-$. Let us note again, that the work of the solvated electron’s extraction from metals (or hydrogen) to the solvent has an analogy with the work of an electron’s extraction from metals under futons’ action. However, in difference from the photo effect, “the ripping out” of electrons in a solution happens at the thermal, not electromagnetic, energy’s expenses. Perhaps, an effective combined photo-thermal “electric pumps” are possible too.

The perspectives

Apparently, all burning cycles of organic fuels can be replaced by the “free” energy from the environment, superlatively incorporated in the natural equilibrium of the biosphere and in the planet’s heat balance; including for the requirements of small, autonomous, domestic and personal energetics. The resource of an autonomous ship’s sailing, cars’ driving and atmospheric flying machines will not be limited by the fuel refilling, and the technical progress in general will be absolutely ecologically clean. The thermal-electronic pumps (TEP) of cryogenic cycle are going to find a use beyond the atmosphere’s limits for space settlements, on the utilization of the spreaded thermal energy of economic activity of Homo cosmetics and extra sun radiation. The constructive simplicity of TEP’s and their ability to be combined with an electric motor and an accumulating battery assume a compact size, many years of resource and a minimum of the exploitation expenses for the thermal power devices. The theoretical limit of the gravitationally stabilized (rotating) accumulators of the dissociated hydrogen’s energy according the schemes $\text{H}_2 \rightarrow \text{H}+\text{H}$ and $\text{H}_2 \rightarrow 2e^-+2p^+$ corresponds to the energy saturation up to 51700 and 362200 kkal/kg, that is 10-100 times more than energetic level of the usual fuels and chemical explosives (fuel + oxidizer). From the beginning of the technical progress the development of the human race were going in direction of the accumulated natural energy sources (fuels) use. However, the universal physical fuel is the energy of the environment with a

temperature higher than 0 K, which is practically anyone of the physical objects. It is enough only to create the necessary conditions for the heat transformation into energy equivalents, in accordance with the universal law of interrelative transformation of the energy forms. And, at the fuelless energetics frame, not the petroleum-air mixture, steam, uranium or the falling water’s energy will be the fuel, but the thermal energy. Apparently, some other “free” forces and external potential fields, for example, the static magnetic field, could be used for the separation of the polar ions in the electric pumps’ cycles. Besides that, the use in a role of a “working body” of not only a substance, but also of the vacuum theoretically is possible. According to the modern ideas about the physical vacuum as of a conglomeration of every possible virtual particle and field [7], the necessary conditions for the birth of “vacuum” electron-positron pairs: e^-+e^+ may also be created. Natural process like that are known, for example, in Kulon’s field of atomic nucleases under “free” futons from the environment. The necessary gradient of electrostatic and mechanical fields near a fast spinning charged surfaces can considerably “lighten” the overcoming of a potential barrier of physical birth for the particle-antiparticle pairs, with their following separation. For example, metal’s surface (the accumulator’s covers) can be looked at as if it is an endlessly immense “molecule” made of atoms (nucleases) in the crystalloid structure’s knots. Separated by the electrostatic field of the spinning “vacuum» pump, the positrons further can annihilate with the electrons of any “free” substance and emit the energy, which is theoretically compensating the waste of energy on the pair’s birth from vacuum ($E=2m_e c^2$), and their antiparticles, when moving to the anodes, present the “free” electric power. There are many wonderful perspectives.

References

1. Studennikov V.V., Kudimov G.I. “The hydrogen energetics: the stage of practical decisions”, in “MIS-RT”, 1999, issue N 18-2
2. Karapetyants M.V., Drakin S.I. The common and inorganic chemistry. – Moscow, Himia, page 396
3. S. Sarnar. “The rocket fuels chemistry. Moscow, Mir, 1969.
4. F. cotton, J. Wilkinson. The inorganic chemistry foundations. Moscow, Mir, 1979, pages 261-262.
5. Kreshkov A.P. Analytical chemistry of non-water solutions. Moscow, Mhimia, 1982, pages 82-83.
6. The unorganikum, by edition of L. Koldith. Moscow, Mir, 1984, volume 1, page 363.
7. Naumov A.I. Physics of the atomic nucleus and elemental particles. Moscow, Prosveschenie, 1984.

The sun water pump

Yuri N. Novozhilov

Bratislavskaya street, 25, apartment 6, Ryazan, 3900000008, Russia

Phone: 7-0912- 72-1276

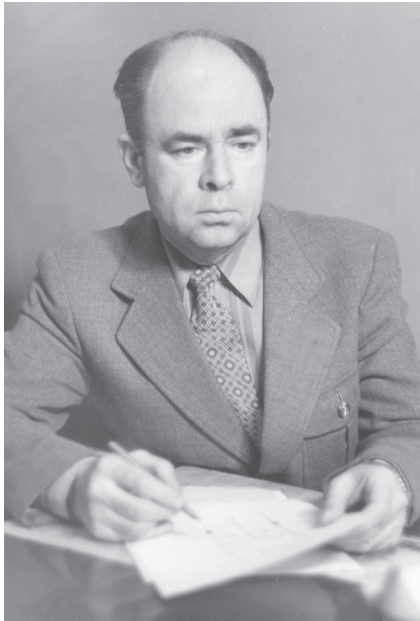

This is a description of a sun water pump, for the drive of which, a power element made of nitinol with the shape memory, is used. Such an element changes its shape when it is heated up, and when it cools down. It is heated up by the sun rays, and it cools down with water or after being shadowed by a curtain. The power element's shape change is used for the pump's drive or any other device.

Millions of Russian citizens like to work in their gardens. And that means that together with the other gardening stuff the watering of the garden plants needs to be done too. The water for that may be pumped with an electric pump from the garden well.

But unfortunately, the electric power is getting more expensive. That's why the question about searching for the new ways of energy saving stands very sharply, both for the big enterprises and for an individual alike.

A pump for the water lifting from a well at the sun's energy expenses is mostly wanted. It would be very good if such a pump, attached to a well, in a dump, cloudy weather does not work and keeps its motor's resource, because the garden watering is not needed in conditions like that. It is not bad, when in a hot, sunny weather the pump starts working by itself, collecting the water for the evening watering. And it should work independently, always when the sun shines, without any man's intrusion.

The hotter the sun's heat, the more water is needed for irrigation; and the pump must work more energetically the whole time, in order to supply more water.

Such a fascinating pump is attainable to make. The main knot of a pump like that is the power element, which is made of metallic alloy with the shape memory.

The first time in history alloys like that were produced about 60 years ago. However, at that time they were made on the basis of gold; and they did not find any practical use then, because of their high prices. Later the shape memory alloys were produced on more accessible metals' basis. Some of those metals are known at the present time. One of the most accessible is the alloy of nickel and titanium mixed approximately in equal proportions. An alloy like that is called nitinol.

These alloys' specialty is in their ability to jumpily transform their shape during a heating up to the determined temperature. During the cooling, an element made of nitinol alloy gets back to its original shape. This happens, because of the alloy's atomic structure restoration. The forces, appearing for the duration of this, are

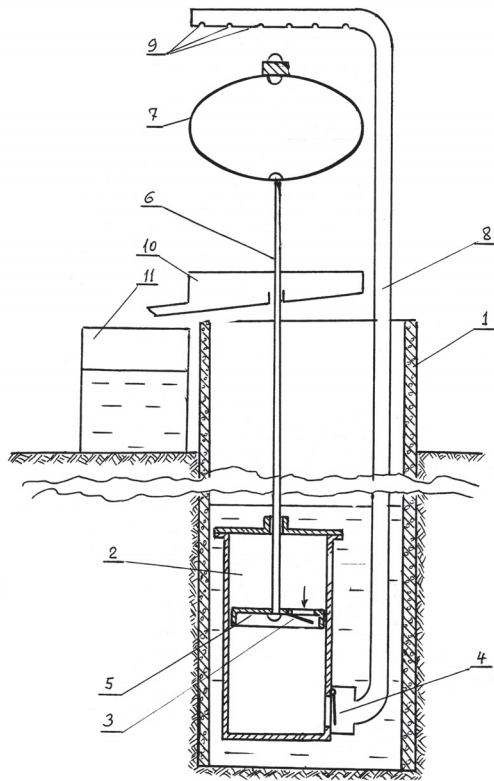

Fig.1

1 – the well; 2 – the pumping unit; 3 – the valve on water entrance; 4 – the valve on water exit; 5 – the pump's piston; 6 – the pole; 7 – the power element made of nitinol; 8 – the pipe; 9 – the holes in the pipe for the water sprinkling of the power element; 10 – the gutter for the water flow; 11 – the barrel

considerably powerful; they can reach up to 7 tons on one square centimeter. That means that an element made of such an alloy can do a specific work.

The temperature diapason, in which this attributes are observed, is quite great, approximately from -200 to -300 degrees C.

For example, if a heated piece of a wire made of nitinol will be given a shape of a stretched spiral spring, and then it will be cooled down and exposed to the mechanical deformation (it is being squeezed), then the spring keeps its new shape at that temperature. But right after the squeezed nitinol spring's heating to the transition temperature, it gets back to its original shape, meaning it is unwinding, becomes a few times longer. During the cooling

of this spring it squeezes back again, growing shorter, its shape becomes again the same as in the cold state of condition, which is right after the deformation.

The element of nitinol with an ability to reconstruct its original shape like that at the determined temperature is the power element of the pump, the foundation of its construction. To the well 1 the pumping unit 2, containing the valves on water entrance and exit, correspondingly 3 and 4, and also the piston 5 of the pumping unit, which is connected to the bottom part of the power element 7, made of nitinol, is immersed. The piston divides the inside space of the pumping unit 2 in two parts – over the piston and under the piston. The power element 7 has the shape of an ellipse made of nitinol stripe. The top part of the element 7 is attached to the stand.

For the water supply from the well from the pumping unit 2 the pipe 8, connected to the valve's 4 at water's exit, box is intended. On the

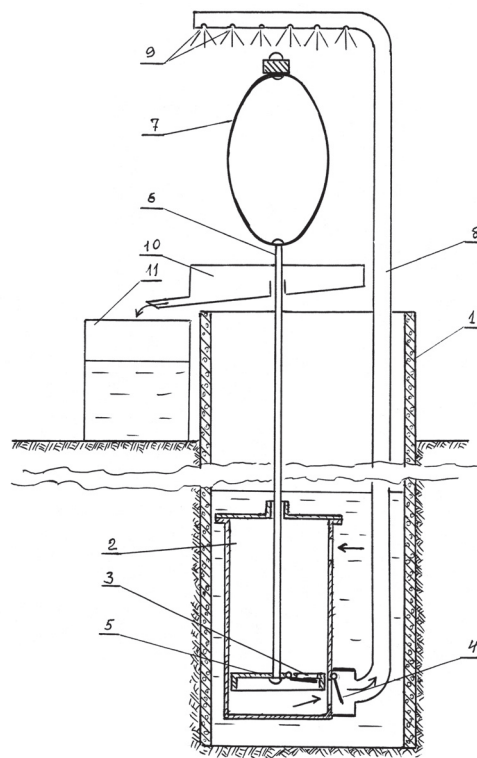

Fig.2

top part of the pipe, a row of holes 9 is made, intended for the sprinkling with cold water from the well of the power element 7, made of nitinol.

For the water gathering the gutter 10, from which the water is poured into the standing next to it barrel 11, is intended.

Operation

When the weather is cool or in the morning, when the sun with its rays did not heat the air and the power element 7 made of nitinol yet, it has the shape of an ellipse, which's bigger axis is horizontal (see picture 1).

In this case the piston 5, positioned in the pumping unit 2 and connected to the power element 7 and the pole 6, will stay at the top position. The empty spaces of the pumping unit are filled with water.

When the sun or warm summer air will heat up the elliptical power element 7 to the shape transforming temperature, it changes the shape quick, but its bigger axis becomes vertical (see picture 2).

As the consequence of that, the pole 6 and the piston 5, connected to it, move down in the pumping unit, at the same time to the empty space above the piston and the water from the well flows through especially intended hole in the unit's wall. But water can not get from the empty space under the piston to the top empty space, so the valve 3 is shut. That's why cold well water from the empty space under the piston during its downward motion through the opened valve 4 flows to the pipe 8, raises up through it and through the holes 9 sprinkles at the power element 7, cooling it down, and then the water is poured into the barrel 11. When it cools down to the shape changing temperature, the power element made of nitinol takes its original shape – ellipse, which's bigger axis is horizontal, like on picture 1. In this case the pole 6 and the connected to it piston 5 raise upward.

Thus the valve 4 closes and prevents water leaks from the pipe 8, and the valve 3 on the piston opens and supplies the water transfer from the empty space above the piston to the empty space under the piston.

Thus, the entire system came to the original state of condition again. The sun or the environmental warm air heat the power element again up to the temperature of its shape change, at the same time the pump sends the next portion of water, which again is cooling the power element down, which, changing its own shape, raises the piston up.

Such work of the solar pump is happening without any people participation and without of the electric energy wasting, but only due to the energy of sun rays or heat of the air. And there is more water needed for the watering, when the sun heats warmer and air is warmer, then, in that case, the solar pump with the nitinol power element works more efficiently, because its work cycles become more frequent. In this construction the power element of nitinol has a look of an ellipse.

However, this element may possibly be of another shape too, for example, in a form of a spiral spring made of a nitinol wire of the corresponding diameter. In accordance with the temperature change this spring will modify its length and, consequently, move the device connected to it to action.

The power element of nitinol, whatever shapes it takes, does not need a supplement of any other energy in addition to the sun's heat, that's why, it is ecologically clean. It can be used not only for the pump's drive, but also for the other machinery and generators.

The construction of a device with the power element of nitinol may be so that the power element, being heated up by the sun rays, is cooling by periodical shadowing with a curtain. And the power element of nitinol moves the curtain by itself for the duration of the transformation of its shape.

A pump like this one or another one with a power element made of nitinol can find the use in many regions, precisely, where is no electric power supply, and the delivery of another kinds of energy resources is difficult, for example on the veils in the desert.

The semiconductor transformer of environment heat to electric current energy

Anatoly N. Zernij

Ukraine Email: zernij@hotmail.com

The modern energetic's problem is in the production of the electric energy, which is, being the source of material goods of the man, who happened to find himself in a mortal withstanding to his environment (which is the nature); and as a result of this, an ecological disaster is inescapable. The search and the discovery of alternative, ecologically clean means of the electric energy collection is the actual task of Humanity. One of the energy sources is the natural environment itself: the air of the atmosphere, the waters of the seas and oceans, which contain a huge quantity of the heat energy received from the sun. The method of transformation heat energy of the environment to the constant electrical current, which is based on contact phenomenon between a metal and semiconductors of different type of conduciveness (see Fig.1).

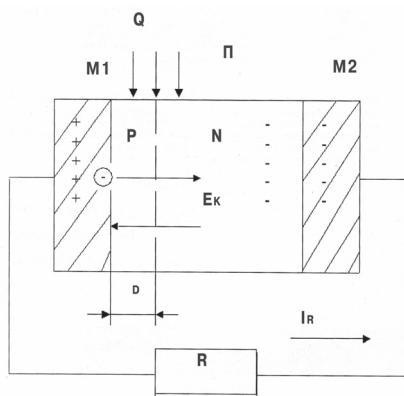

Fig.1

The principle scheme of the alternator. Where: P – the semiconductor's crystal (silicon of the n-type), p-n – the crossing with a contact electric field E_k , M1 – the metal contact with a p-area (aluminum), M2 – the metal contact with n-area (aluminum), d- the depth of p-n crossing's flight (not more than 10 mkm), R_h – the external load resistance.

The alternator's work principle is following. For example, the work on electron's exit from the semiconductor of n-type makes 4.25 eV, of the p-type – 5.25 eV and of the aluminum – 4.25 eV. That's why the contact M_2 with the semiconductor of n-type is omic and does not affect the alternator's work, and the contact M_1

with a semiconductor of the p-type is injecting one. Under the action of thermal movement powers and as a result of exit work's difference, electrons from the metal contact M_1 will be injected to the p-area of the semiconductor. One part of the electrons recombines with the p-area crystal holes, and the second part of the electrons will be overthrown by the electric field p-n of the E_k crossing to the n-area of the crystal. At that the semiconductor's crystal's n-area and the contact M_2 will be charged negatively, and contact M_1 because of the electron's leave from it, positively, which will lead in the end to the appearance of difference of the electric potentials between M_1 and M_2 contacts.

The electrons' stream from M_1 and M_2 will be taking place, till the raising electrical field between the contacts creates an opposite stream of electrons from the n-area to the p-area of the crystal, because of the potential barrier of the p-n crossing decrease. When these currents of the electrons become leveled, an electrical and thermodynamic equilibrium will be established in the isolated crystal. Thus between the contacts M_1 and M_2 will be established a potentials difference, which will be equal the half of contact difference of potentials p-n crossing (in this case – 0.55V), which means a presence between them of Electro Motive Force. If we connect the contacts M_1 and M_2 with an external metallic conductor with a resistance R_h , then the electrical and thermo dynamical equilibrium of the semi conductive crystal will be broken and in the load chain the electric current IR_h will flow. At this, the p-n crossing will be cooling down, because the energy of electrons, coming from the p-area to the n-area of the semiconductor will be raised at the inner (thermal) energy of the crystal's structure of the semiconductor. For the support in the chain of a load of constant by its values current, to the crystal it is necessary to supply the heat from the environment.

Alternative Energy Projects in Germany

Reviewed by A. V. Frolov

Source documents are published on web site <http://www.evert.de>



*Prof. Alfred Evert
Wilhelm-Kopf-Strasse 40
D 71672 Marbach
fred@evert.de
evert@t-online.de*

In early August we got in touch with Prof. A. Evert and asked him some questions about the course of his experiments. Interesting data about high-performance turbines, vortex machines like Clem- motor and mechanical devices, creating turning moment on the shaft due to constant mass imbalance was presented on his web-site. Prof. Evert expressed a desire to introduce his notion of ether used in his experiments to our readers. We hope that this review will rouse interest of our readers.

Gravity- Centrifugal Motor

Fig. 1 shows a constantly rotating motor, that has 12 radial masses.

Every mass is situated between the inner and the outer radial spring. The centre of gravity in the system is offset, so that the rotor is theoretically accelerated. This concept may be

useful in construction of constantly revolving and self-accelerated machine, a perpetual motion machine literally. These machines will not consume any energy. Still the source of excess energy is well-known: easy access to gravitational energy combined with centrifugal forces. One should notice that the energy

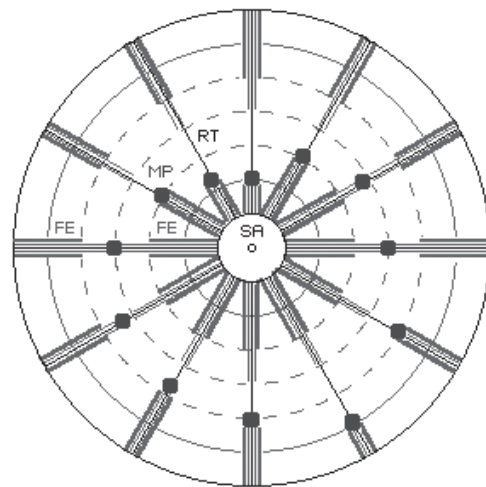

Fig.1

conservation law applied to impetus is not violated here. Energy turns into yield only due to rational build-up: there occurs intermediate storage of excess energy when it's not needed to rotate, and it's applied later, when it can have beneficial action to increase the turning moment of the system. One should mark, that the 3rd type of energy – forces of molecular adhesion - is also applied here. It is the flexible material of springs that performs yield, returning to its normal state. Of course, forces of molecular adhesion do not serve as a source of energy, but they act as an instrument to organize the necessary process of motion. This structure was suggested by Prof. Evert in August, 2001.

Oscillation Motor

Fig. 2 presents a rotor with radial elements with a pendulum at the end of each.

In the lower phase of the pendulum potential energy of its weight transforms into kinetic energy of its motion which can be used to increase the turning moment of the rotor. Please pay your attention that Prof. Evert marks the necessity of spring elements.

The scheme has a direct relationship to the so called Bessler principle: masses can be directed along the radius of various lengths, that creates dissymmetric trajectory and resultant force.

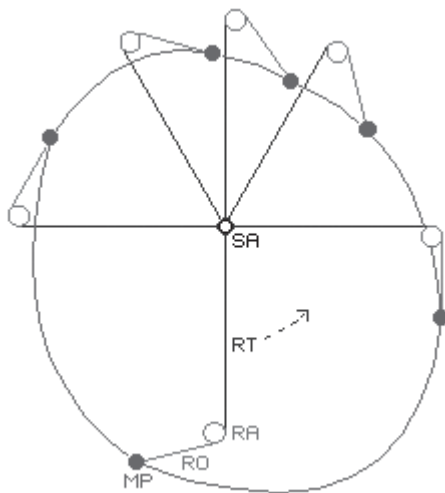

Fig.2

This effect can be achieved due to springs, mechanical joints or various elastic elements. Non-productive (from the turning moment's point of view) forces should be transformed into material deformation of various elements, that's why the relaxation of these elements will lead to the increase of the turning moment of the system.

Fig. 3 shows a rotor with radial elements in various positions.

The wheel will be turning at steady speed, Prof. Evert claims. Fig. 4 presents one more scheme, the basic elements of which are: rotor, springs and masses.

In the upper position the spring will be compressed by the weight of the plummet, then it's released and the radius increases. Fig. 5 gives a good idea how the mass centre of the system is offset.

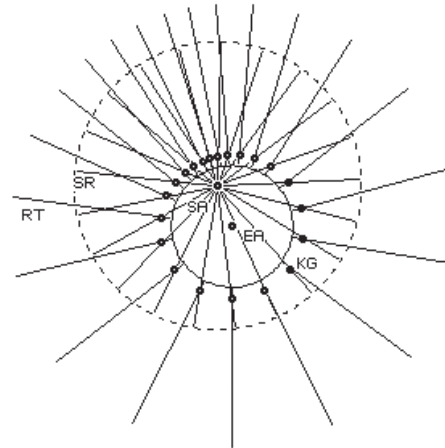

Fig.3

Prof. Evert makes a request to our readers, asking to collaborate with people who can create working models or help with computer simulation of these processes.

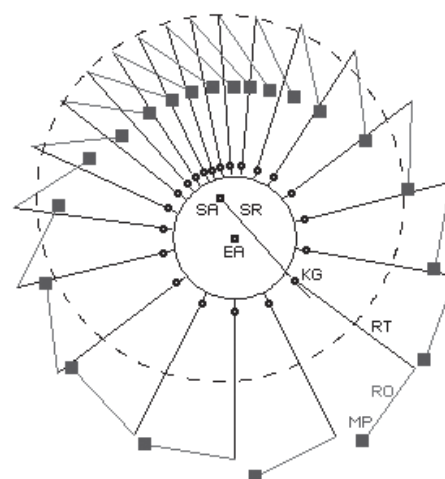

Fig.4

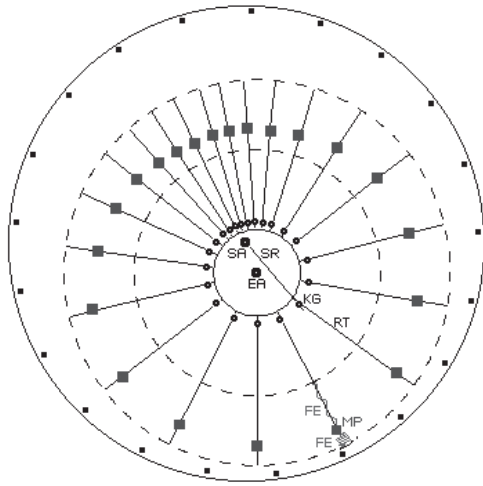

Fig.5

Pendulum Wheel

Fig. 6 shows a wooden model of an asymmetric pendulum designed by Prof. Evert.

In some phases of its work the process coincides with theory perfectly, but the device doesn't function properly and can't be in constant motion. Fig. 7 presents a structure of 3 pendulums set on one rotor. Theoretically the system is self-accelerating, but only up to a



Fig.6.2

definite speed. Prof. Evert considers this attempt to be a prospective and interesting enough. To obtain a positive result one should design a model with better quality.



Fig.6.1

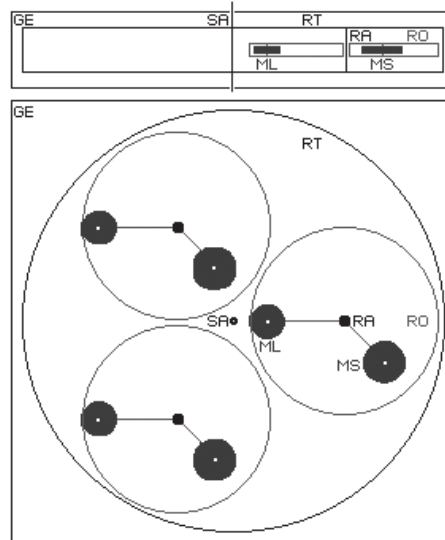

Fig.7

Bessler's Wheel

Fig. 8 is photo of the wooden model, tested by Prof. Evert in his laboratory. The model is constructed of the most primitive materials. The theoretically expected effects are really visible. But the problem of this model is the fact, that the spring is not compressed at once, and this delay influences the work of the system.



Fig.8.1



Fig.8.2

Sun Wheel

Fig. 9 shows the operational principle of another device suggested by Prof. Evert.

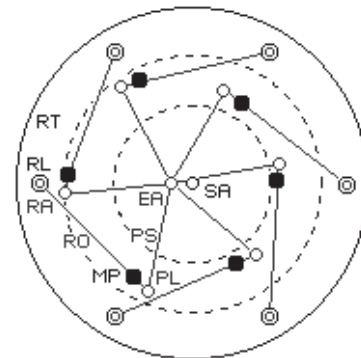

Fig.11

The variations of this principle are Fig. 10.

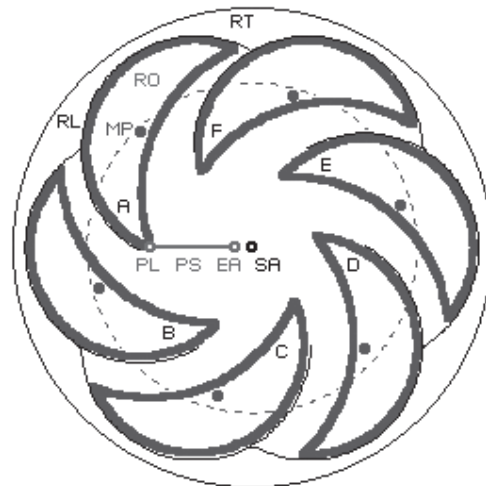

Fig.10

The minimal possible number of working elements is three, as it's shown in Fig. 11.

Turbines

Fig. 12 illustrated the scheme of the turbine suggested by Prof. Evert.

The inlet of water is performed in the centre of the system, axially. Pay your attention to the original form of the stator.

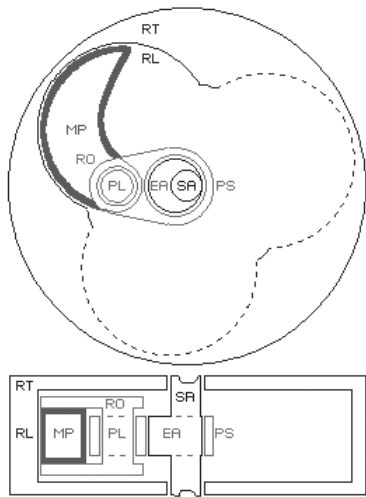

Fig.11

As Prof. Evert says, Viktor Shauger applied special engineering principles in his turbines. Fig. 13 and 14 from Shauger's patent give an idea of the effect, that lets to achieve axial tractive force in turbines of the kind.

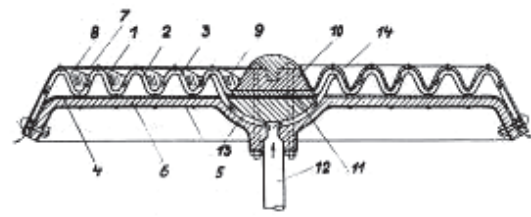

Fig.13

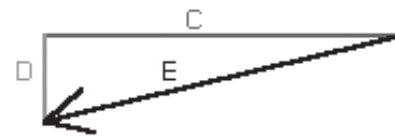

Fig.14

It is produced due to special trajectory of water motion, moving radially and simultaneously, as it's shown in Fig. 14 and they're rotating, as it's shown in Fig. 15.

vortexes are produced with minimal energy consumed, but they provide immense kinetic energy of water molecules.

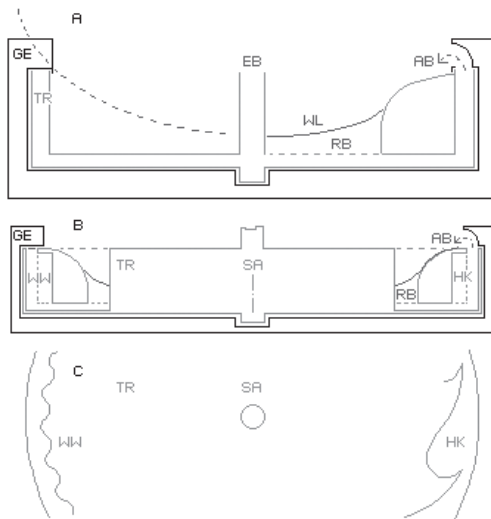

Fig.12

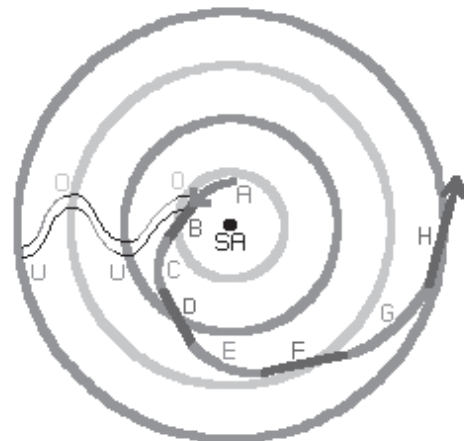

Fig.15

As illustrated in Fig. 16, one can see Prof. Evert's proposal to construct turbines, where

Of fundamental importance is resonance in turbines and the shape of the turbine nozzle. Fig. 17 shows examples of turbines with dirigible resonance projects.

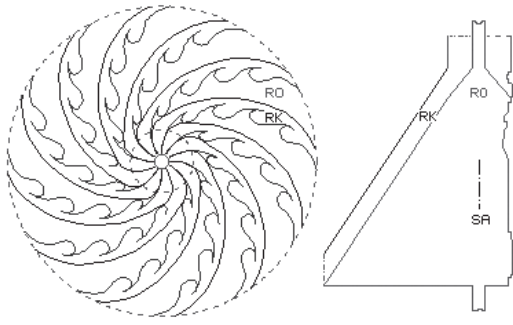

Fig.16

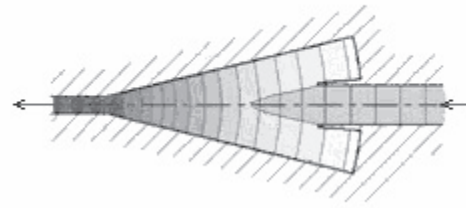

Fig.17.3

The experimental and theoretical research carried out by Prof. Evert deserves great attention and respect. We hope that this review will be helpful to developers of autonomous energy sources, including vortex propulsion drive.

The basic construction of these turbines is sketched in Fig. 18 and 19.

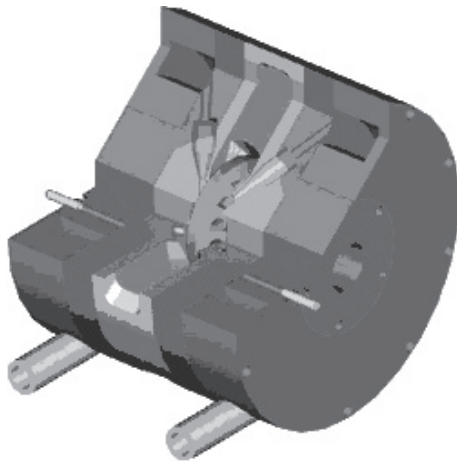

Fig.17.1

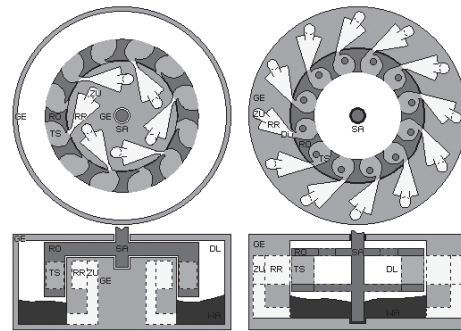

Fig.18



Fig.17.2

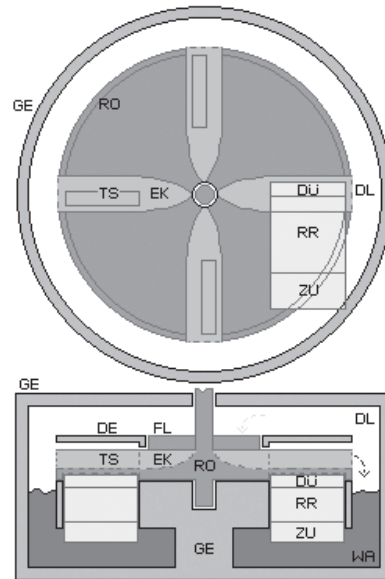

Fig.19

Prospects for Breakthrough Propulsion from Physics

Marc G. Millis

NASA Glenn Research Center, Cleveland Ohio 44145 USA

Abstract

"Space drives," "Warp drives," and "Wormholes:" these concepts may sound like science fiction, but they are being written about in reputable journals. To assess the implications of these emerging prospects for future spaceflight, NASA supported the Breakthrough Propulsion Physics Project from 1996 through 2002. This Project has three grand challenges: (1) Discover propulsion that eliminates the need for propellant; (2) Discover methods to achieve hyper-fast travel; and (3) Discover breakthrough methods to power spacecraft. Because these challenges are presumably far from fruition, and perhaps even impossible, a special emphasis is placed on selecting incremental and affordable research that addresses the critical issues behind these challenges. Of 16 incremental research tasks completed by the Project and from other sponsors, about a third were found not to be viable, a quarter have clear opportunities for sequels, and the rest remain unresolved.

1. Introduction

New theories and phenomena have emerged in recent scientific literature that have reawakened consideration that propulsion breakthroughs may become achievable - the kind of breakthroughs that could make human voyages to other star systems possible. This includes literature about warp drives, wormholes, quantum tunneling, vacuum fluctuation energy, and the coupling of gravity and electromagnetism. This emerging science, combined with the realization that rockets are fundamentally inadequate for interstellar exploration, led NASA to establish the "Breakthrough Propulsion Physics (BPP)" Project in 1996 [1].

This paper summarizes the methods and findings of this Project as well as findings from other parallel efforts. The methods are described to reflect the special management challenges and corresponding mitigation strategies for dealing with such visionary topics in a constructive manner. Projections of future research are also offered.

2. Methods

As the name implies, the BPP Project is specifically looking for propulsion breakthroughs from physics. It is not looking for further technological refinements of existing methods. Such refinements are explored in other NASA projects. Instead, this Project looks beyond the known methods, searching for further advances from emerging science from which genuinely new technology can develop - technology to surpass the limits of existing methods.

2.1. Technical Challenges

The first step toward solving a problem is to define the problem. The following three Grand Challenges represent the critical discoveries needed to revolutionize spaceflight and enable interstellar missions:

Challenge 1 - MASS: Discover new propulsion methods that eliminate or dramatically reduce the need for propellant. This implies discovering fundamentally new ways to create motion, presumably by interacting with the properties of space, or possibly by manipulating gravitational or inertial forces.

Challenge 2 - SPEED: Discover how to dramatically reduce transit times. This implies

discovering a means to move a vehicle near the light-speed limit through space, or by manipulating spacetime to circumvent the light-speed limit.

Challenge 3 - ENERGY: Discover fundamentally new modes of onboard energy production to power these propulsion devices. This third goal is included since the first two breakthroughs might require breakthroughs in energy generation, and since the physics underlying the propulsion goals is closely linked to energy physics.

2.2. Special Challenges and Mitigations

The combination of high-payoff prospects plus the speculative nature of the edge of knowledge evokes special management challenges. To produce credible progress under these conditions, the BPP Project employs the following operating strategies:

- **Reliability:** Success is defined as acquiring reliable knowledge, rather than as achieving a breakthrough. This emphasis steers publications toward credible progress and away from sensationalistic claims.
- **Immediacy:** Research is focused on the immediate unknowns, make-or-break issues, or curious effects.
- **Iterated:** Overall progress is achieved by repeating a cycle of short-term, incremental tasks.
- **Diversified:** Multiple, divergent research topics are explored simultaneously.
- **Measured:** Progress is tracked using a combination of the scientific method and the applicability of the research to the Project's goals.
- **Impartial:** Reviewers judge credibility and relevance, but are not asked to predict the feasibility of research approaches.
- **Empirical:** Preference is given to experiments and empirical observations over purely analytical studies.
- **Published:** Results are published, regardless of outcome. Null results are also valuable progress.

Given the kind of fundamental investigations sought by this Project, it is difficult to reliably determine technical feasibility during a proposal review. Such an assessment would

constitute a full research task itself. Typically, when confronted with the kind of unfamiliar ideas related to this endeavor, many reviewers will reflexively assume that the new idea will not work. To prevent premature dismissal, proposal reviewers are asked to judge if the work is leading to a result that other researchers will consider as a reliable conclusion on which to base future investigations. This includes seeking tasks that can demonstrate that certain research approaches are not feasible. This posture of judging credibility, rather than pre-judging correctness, is one of the ways that the BPP Project is open to visionary concepts while still sustaining credibility.

3. Findings

In addition to the 8 tasks supported through the BPP Project, at least 8 additional tasks were supported by others, and several related research efforts continue. Of the 16 specific tasks reported and summarized here, 6 were found not to be viable, 6 remain unresolved or have debatable findings, and 4 have clear opportunities for sequels. It should be stressed, however, that even interim positive results do not imply that a breakthrough is inevitable. Often the opportunity for sequels is more a reflection of the embryonic state of the research. Reciprocally, a dead-end conclusion on a given task does not imply that the broader related topics are equally defunct. Both the null and positive results should only be interpreted within the context of the immediate research task, and not generalized beyond. This is consistent with the operating strategy to focus on the immediate stage of the research, and the strategy to put a higher priority on the reliability of the information rather than on producing broad-sweeping claims.

It should also be stressed that these task summaries do not reflect a comprehensive list of research options. It is expected that new concepts will continue to emerge in such an embryonic field.

3.1. BPP Sponsored Research

The NASA BPP Project sponsored 5 tasks through competitive selection, 2 in-house tasks, and 1 minor grant. From this work, 13 peer-

reviewed journal articles resulted [1-13]. Summaries of each of the 8 tasks are offered below.

3.1.1. Define Space Drive Strategy.

"Space drive" is a general term to encompass the ambition of the first BPP Challenge: propulsion without propellant. To identify the unresolved issues and research paths toward creating a space drive, this in-house task conceived and assessed 7 hypothetical space drives. The two largest issues facing this ambition are to first find a way for a vehicle to induce external, net forces on itself, and secondly, to satisfy conservation of momentum in the process. Several avenues for research remain, including: (1) investigate space from the perspective of new sources of reaction mass, (2) revisit Mach's Principle to consider coupling to surrounding mass via inertial frames, and (3) investigate the coupling between gravity, inertia, and controllable electromagnetic phenomena [2]. These are very broad and open areas where a variety of research sequels could emerge.

3.1.2. Test Schlicher Thruster.

In-house experiments were performed to test claims that a specially terminated coax, as reported by Rex Schlicher [14], could create more thrust than attributable to photon radiation pressure. Tests observed no such thrust [15].

3.1.3. Assess Deep Dirac Energy.

Theories based on the work of Dirac assert that additional energy levels and energy transitions might be possible in atomic structures [16]. A theoretical assessment, supported via a grant to Robert Deck (Univ. Toledo, Grant NAG 3-2421), found that several of the predicted energy transitions are not possible. Other unexplored possibilities remain. This topic is not fully resolved. Findings have been submitted for journal publication.

3.1.4. Cavendish Test of Superconductor Claims.

As a lower-cost alternative to a full replication of the Podkletnov "gravity shielding" claim

[17], Cavendish balance experiments were performed using superconducting materials and radio frequency (RF) radiation according to related theories. It was found that the RF radiation coupled too strongly to supporting instrumentation and prevented any discernable results [18]. No sequels to this approach are expected.

Other groups sponsored full replications of the Podkletnov configuration, and their findings are presented in section 3.2.3.

3.1.5. Test Woodward Transient Inertia.

Experiments and theories published by James Woodward claim that transient changes to inertia can be induced by electromagnetic means [19, 20], and a patent exists on how this can be used for propulsion [21]. Independent verification experiments, using techniques less prone to spurious effects, were sponsored. Unfortunately, when subsequent publications by Woodward indicated that the effect was much smaller than originally reported [22], the independent test program had to be changed. The revised experiments were unable to resolve any discernable effect with the available resources [23]. Woodward continues with experiments and publications [24], and has begun addressing the theoretical issues identified during this independent assessment. This transient inertia approach is considered unresolved.

3.1.6. Test EM Torsion Theory.

Theories using a torsion analogy to the coupling between electro-magnetism and spacetime [25] indicate the possibility of asymmetric interactions that might be of use, at least in principle, for propulsion [26]. Experiments were sponsored to test a related prediction of the theory, but the results were null. Further analysis indicates that the experiments missed a critical characteristic to correctly resolve the issue [27]. This approach is considered unresolved.

3.1.7. Explore Superluminal Tunneling.

A pre-requisite to faster-than-light travel is to prove faster-than-light information transfer.

The phenomenon of quantum tunneling, where signals appear to pass through barriers at superluminal speed, is often cited as such empirical evidence. Experimental and theoretical work was sponsored to explore the special case where energy is added to the barrier (tunnel). Even in this case it was found that the information transfer rate is still only apparently superluminal, with no causality violations. Although the leading edge of the signal does make it through the barrier faster, the entire signal is still light-speed limited [3-5]. Although other quantum phenomena still suggest faster-than-light connections (e.g. quantum entanglement), the venue of quantum tunneling does not appear to be a viable approach for exploring faster-than-light propulsion.

3.1.8. Explore Vacuum Energy.

Quantum vacuum energy, also called zero point energy (ZPE), is a relatively new and not fully understood phenomenon. In simple terms, the uncertainty principle from quantum mechanics indicates that it is not possible to achieve an absolute zero energy state. This includes the electromagnetic energy state of the space vacuum [28]. It has been shown analytically, and later experimentally, that this vacuum energy can squeeze parallel plates together [29]. This "Casimir effect" is only appreciable at very small dimensions (microns). Nonetheless, it is evidence that space contains something that might be useful. The possibility of extracting this energy has also been studied. In principle, and without violating thermodynamic laws, it is possible to convert minor amounts of quantum vacuum energy [30, 31].

The BPP Project sponsored experimental and theoretical work to further explore the tangibility of this phenomenon. New analytical and experimental tools were developed to explore this phenomenon using MicroElectroMechanical (MEM) rectangular Casimir cavities [6-12]. It was even shown that, in principal, it is possible to create net propulsive forces by interacting with this energy, even though the forces are impractically small at this stage [13]. Regardless of these immediate impracticalities, however, the quantum vacuum does offer an experimental venue through which to further study the very structure of space itself. Continued research on

this phenomenon and through these techniques is expected.

3.2. Research Sponsored by Others

While the NASA BPP Project scouted for multiple, divergent research approaches using competitive solicitations, several other organizations focused on individual tasks. Several examples of such work are presented next.

3.2.1. Slepian-Drive.

Funded through a Congressional earmark, the West Virginia Institute for Scientific Research (ISR) is conducting experimental and theoretical assessments of the propulsive implications of electromagnetic momentum in dielectric media. The equations that describe electromagnetic momentum in vacuum are well established (photon radiation pressure), but there is still scientific debate concerning momentum within dielectric media, specifically the "Abraham-Minkowski controversy."

More than one concept exists for how this might apply to propulsion and several terms are used to refer to this topic, such as "Slepian-Drive," "Heaviside Force," "Electromagnetic Stress-Tensor Propulsion," and the "Feynman Disk Paradox." To date, ISR has submitted a tutorial paper on the phenomenon to a journal, and has produced a conference paper on interim experimental findings [32]. An independent assessment by the Air Force Academy concluded that no net propulsive forces are expected with this approach [33].

Separate from the ISR work, independent research published by Dr. Hector Brito details a propulsive device along with experimental data [34]. The signal levels are not sufficiently above the noise as to be conclusive proof of a propulsive effect.

While not specifically related to propulsion, a recent journal article assessed the Abraham-Minkowski controversy from a quantum physics perspective, suggesting it might be useful for micro-fluidics or other applications [35].

In all of these approaches, the anticipated forces

are relatively small, and critical issues remain unresolved. In particular, the conversion of oscillatory forces to net forces (Slepian-Drive) remains questionable, and the issue of generating external forces from different internal momenta remains questionable. Even if not proven suitable for propulsion, these approaches provide empirical tools for further exploring the Abraham-Minkowski controversy of electromagnetic momentum. This topic is considered unresolved.

3.2.2. Cosmological Consequences of Vacuum Energy.

Theoretical work, sponsored by NASA Headquarters from 1996 to 1999 [Contract NASW-5050], examined the role played by quantum vacuum energy on astrophysical observations. Of the 5 journal articles that resulted [36-40], the last two pertain most to breakthrough propulsion. These made the controversial assertion that inertia might be an electromagnetic drag force that occurs during accelerated motion through vacuum energy. This led to speculation that it might become possible to alter inertial properties through some electromagnetic means [41]. Work toward this perspective continues, but through private sponsorship, described in section 3.3.4.

3.2.3. Tests of Podkletnov Claim.

In 1992, a controversial claim of a "gravity shielding" effect was published by E. Podkletnov based on work done at Finland's Tampere Institute [17]. Regrettably, the article was not fully forthcoming with all of the experimental methods and jumped to the conclusion that a gravity shield effect was responsible for the anomalous weight reductions observed over spinning superconductors. Although others dismissed this effect on the grounds that it violates conservation of energy [42], this dismissal itself did not take into account that the claimed effect consumes energy.

From 1995 to 2002, NASA Marshall Space Flight Center (MSFC) attempted a full experimental replication of the Podkletnov configuration [43], but was not able to complete the test hardware with the available resources.

A privately funded replication of the Podkletnov configuration was completed by Hathaway, Cleveland and Bao, and the results published in 2003 [44]. This work "found no evidence of a gravity-like force to the limits of the apparatus sensitivity," where the sensitivity was "50 times better than that available to Podkletnov." Therefore, this rotating, RF-pumped superconductor approach is considered non-viable.

3.2.4. Podkletnov Force-Beam Claims.

Through undisclosed sponsorship, Podkletnov produced a new claim - that of creating a force-beam using high-voltage discharges near superconductors. His results, posted on an Internet physics archive [45], claim to impart between 4×10^{-4} to 23×10^{-4} Joules of mechanical energy to a distant 18.5-gram pendulum.

Like his prior "gravity shielding" claims, these experiments would be difficult and costly to duplicate, and remain unsubstantiated by reliable independent sources.

3.2.5. Gravity Modification Study.

The European Space Agency (ESA) sponsored a study on the prospects of gravity control for propulsion [46]. The following research avenues were identified:

- Search for violations of the Equivalence Principle through ongoing in-space experiments.
- Resolve the anomalous trajectories of Pioneer 10/11, Galileo, and Ulysses [47], via a "Sputnik-5" probe.
- Experimentally explore gravitomagnetic fields in quantum materials [48].

Opportunities for continued research clearly exist on any of these options.

3.2.6. Anomalous Heat Effect.

Although not covered within the confines of breakthrough propulsion research, the controversial topic of "cold fusion" is often encountered when addressing the edge of energy conversion physics. It is in the spirit of completeness that the findings of a decade of

research by the Naval Research Labs (NRL) are mentioned here. In their 119-page report [49], various experiments with conflicting results are described. The Forward to this compilation states: "It is time that this phenomenon be investigated so that we can reap whatever benefits accrue from additional scientific understanding." This report serves as a broad overview of the variety of techniques and issues encountered. This remains a controversial topic.

3.2.7. Biefeld-Brown and Variants.

In 1928 a device was patented for creating thrust using high-voltage capacitors [50]. Since then, a wide variety of variants of this "Biefeld-Brown" effect, such as "Lifters" and "Asymmetrical Capacitors" have claimed that such devices operate on an "electrostatic antigravity" or "electrogravitic" effect. One of the most recent variants was patented by NASA-MSFC [51]. To date, all rigorous experimental tests indicate that the observed thrust is attributable to ion wind [52-54].

Vacuum tests currently underway, sponsored through an additional Congressional earmark to the West Virginia Institute for Scientific Research, also indicate that this effect is not indicative of new propulsion physics. These tests are now assessing the more conventional performance of such devices [55].

These "Biefeld-Brown," "Lifter" and "Asymmetrical Capacitor Thrusters" are not viable candidates for breakthrough physics propulsion.

3.3. Ongoing Activities

In addition to the discrete research tasks previously described, there are a few continuing areas of research.

3.3.1. Metric Engineering.

As a consequence of Einstein's General Relativity, the notion of warping space to circumvent the light-speed limit is a growing topic in scientific literature [56-65]. In basic terms, if one cannot break the light-speed limit through space, then alter space. Two prominent approaches are the warp drive and the wormhole. The warp drive concept involves

moving a bubble of spacetime, which carries a vehicle inside [61]. A wormhole, on the other hand, is a shortcut through spacetime created by extreme spacetime warping [57, 59]. Enormous technical hurdles face these concepts. In particular, they require enormous quantities of "negative energy" (equivalent mass of planets or suns), and evoke time-travel paradoxes ("closed-time-like curves").

In 1994, NASA sponsored a small workshop to assess these prospects [66]. The results fed into the BPP Project and led to an article defining the visual signature of a wormhole as a guide for astronomical searchers for black-hole related phenomena [67]. Recently, the term "metric engineering" [65] has emerged at aerospace conferences to represent such space-warping propulsion concepts. The origin of this term is unknown.

Given the magnitude of energy requirements to create perceptible effects, it is unlikely that experimental work will be forthcoming in the near future. Even though these theoretical concepts are extremely unlikely to be engineered, they are at least useful as teaching tools to more thoroughly explore the intricacies of Einstein's General Relativity. It is likely that theoretical work will continue to emerge on this topic.

3.3.2. High Frequency Gravitational Waves.

Fundamentally, gravitational waves are perturbations in spacetime caused by violent accelerations of large masses, such as collisions of black holes. Ongoing research focuses on low frequency gravitational waves (<1000-Hz) using large interferometers, such as the Laser Interferometer Gravitational Wave Observatory (LIGO) detector whose arms are 4-km (2.5-mi) in length [68].

In contrast, alternative approaches have been suggested to detect High Frequency Gravitational Waves (HFGW). A variety of experimental approaches (introduced at a 2003 workshop) were summarized in a recent conference paper [69]. These detection concepts typically involved desktop size devices, with implications for communication, imaging, and fundamental physics research. Some of the key

issues governing the viability of such devices include the energy transfer mechanisms and the low efficiencies predicted. This is an embryonic area where a wide variety of research remains to be addressed.

3.3.3. Project Greenglow, British Aerospace Sys

Similar to the NASA BPP Project, British Aerospace Systems, Inc. sponsored a modest project to look at a variety of breakthrough propulsion approaches. Headed by Dr. Ron Evans, incremental research tasks were supported that included assessments of Podkletnov's gravity shield claims (null findings) [70], experimental and theoretical works on microwave thrusters [71], and various theoretical works on gravitation [72-76], vacuum forces [77], and "what-if" assessments [78]. It is not known if, or at what level, this project will continue.

3.3.4. Private Quantum Vacuum Research.

Since 1990, the small Advanced Studies Institute, in Austin Texas, has been supported through private funds to test claims of new energy devices and related physics [31, 41, 79-82]. Their most relevant publications for BPP deal with the connection between the quantum vacuum and the definitions of inertia and gravity [41, 79, 81]. Like the NASA-HQ sponsored task previously mentioned, these make the controversial assertion that inertia is merely an electromagnetic drag force against the quantum vacuum fluctuations [81] and closely related, that gravity is a consequence of the quantum vacuum fluctuations [79]. Beginning in 2000, the small California Institute for Physics and Astrophysics (CIPA) has also been privately supported to conduct research on quantum vacuum physics. Their work also explores the controversial assertion that inertia is an electromagnetic drag force, in addition to exploring other issues [83-88].

4. Future Prospects

The search for new, breakthrough propulsion methods from physics is an embryonic field encompassing many differing approaches and challenges. In addition to the research already

described, there are many more approaches published in the literature and presented at aerospace conferences.

At this stage it is still too early to predict which, if any, of the approaches might lead to a successful breakthrough. Objectively, the desired breakthroughs might be impossible to achieve. Reciprocally, history has shown that breakthroughs tend to take the pessimists by surprise.

A key challenge, in addition to the daunting physics, is dealing with such visionary topics in a credible, impartial, and productive manner. When considering future prospects, this management challenge must be taken into account to ensure genuine, reliable progress. The methods used by the NASA Breakthrough Propulsion Physics Project are offered as a benchmark.

4.1. Research Support

Much of the past research has been conducted in the form of individual discretionary efforts, scattered across various government, academic, and private organizations. This practice of isolated efforts is likely to continue, but there is no way to gauge the level of effort or the fidelity of this research. The more rigorous and open progress will continue to appear in the peer-reviewed journals, however.

Regarding the NASA BPP Project, future funding is uncertain. NASA is now assessing how to respond to the President's priorities on Moon and Mars exploration. It is not clear if there is a place for propulsion physics research within these priorities. Previously, the President's Aerospace Commission recommended supporting such visionary work. Quoting from the Commission's report [89]: "In the longer-term, breakthrough energy sources that go beyond our current understanding of physical laws... must be credibly investigated in order for us to practically pursue human exploration of the solar system and beyond. These energy sources should be the topic of a focused, basic research effort." If NASA sponsorship resumes, it might appear under the revised title: "Fundamental Propulsion Physics."

Regarding the privately sponsored projects,

such as the British Aerospace Systems' Project Greenglow and the institutes that examine quantum vacuum physics, future funding details are unknown. Recently, an Aviation Week and Space Technology article states: "At least one large aerospace company is embarking on ZPE [quantum vacuum] research in response to a Defense Dept. request." [90] Given the private and protected nature of such sponsorship, it is not known to what extent these results will be disseminated.

4.2. Research Options

The few research approaches that have been summarized here mostly started from the point of view of seeking propulsion breakthroughs, and went on to confront the immediate issues and unknowns that these goals evoked. Many of these approaches await resolution and many sequels to these approaches remain unexplored.

In addition to this propulsion-initiated perspective, an alternative approach is to examine the various disciplines of physics, and then ask how their emerging insights, and anomalies, might be relevant to propulsion. In the first step of the scientific method, where one clearly formulates the problem to guide the search for knowledge, the propulsion challenge is different than the broader scientific objective to fully understand nature. This change in focus presents a different perspective, and therein provides an opportunity to possibly discover what the more general approach might overlook.

Both of these perspectives, studying the physics required for propulsion, and considering the propulsive implications of emerging physics, provide many options for future research.

5. Concluding Remarks

A wide variety of small research tasks explored the physics issues associated with seeking breakthrough propulsion. Although many approaches were found to be dead-ends, more remain unresolved and further possibilities remain unexplored. At this stage, the work is embryonic and faces challenges typical of any new, emerging area.

The use of trademarks or names of

manufacturers is for accurate reporting and does not constitute an official endorsement, either expressed or implied, of such products or manufacturers by the National Aeronautics and Space Administration.

6. References

- [1] Millis, M.G., "NASA Breakthrough Propulsion Physics Program", *Acta Astronautica*, 44 (1999), pp. 175-182.
- [2] Millis, M.G., "Challenge to Create the Space Drive", *AIAA Journal of Propulsion and Power*, 13 (1997), pp. 577-582.
- [3] Mojahedi, M., Schamiloglu, Hegeler, and Malloy, "Time-domain detection of superluminal group velocity for single microwave pulses", *Physical Review E*, 62 (2000) pp. 5758-5766.
- [4] Mojahedi, M., Schamiloglu, Kamil, and Malloy, "Frequency Domain Detection of Superluminal Group Velocities in a Distributed Bragg Reflector", *IEEE Journal of Quantum Electronics*, 36 (2000), pp. 418-424.
- [5] Segev, B., Milonni, Babb, and Chiao, "Quantum noise and superluminal propagation", *Physical Review A*, 62 (2000), pp. 0022114-1 - 0022114-15.
- [6] Maclay, G. J., "Analysis of zero-point electromagnetic energy and Casimir forces in conducting rectangular cavities", *Physical Review A*, 61 (2000), pp. 052110-1 to 052110-18.
- [7] Esquivel-Sirvent, R., Villarreal, and Coccoletzi, "Superlattice-mediated tuning of Casimir forces", *Physical Review A*, 64 (2001), pp. 052108-1 to 052108-4.
- [8] Maclay, G.J., Fearn, and Milonni, "Of some theoretical significance: implications of Casimir effects", *European Journal of Physics*, 22 (2001), pp. 463-469.
- [9] Esquivel-Sirvent, R., Villarreal, Mochan, and Coccoletzi, "Casimir Forces in Nanostructures", *Physica Status Solidi (b)*, 230 (2002), pp. 409-413.
- [10] Mochan, W.L., Esquivel-Sirvent, and Villarreal, "On Casimir Forces in Media with Arbitrary Dielectric Properties", *Revista Mexicana de Fisica*, 48 (2002), p. 339.
- [11] Villarreal, C., Esquivel-Sirvent, and Coccoletzi, "Modification of Casimir Forces due to Band Gaps in Periodic Structures", *International Journal of Modern Physics A*, 17 (2002), pp. 798-803.
- [12] Milonni, P.W., and Maclay, "Quantized-Field Description of Light in Negative-Index Media," *Optics Communications*, 228 (2003), pp. 161-165.
- [13] Maclay, J. and Forward, R., "A Gedanken spacecraft that operates using the quantum vacuum (adiabatic Casimir effect)", *Foundations of Physics*, 34 (March, 2004) pp. 477-500.
- [14] Schlicher, R.L, Biggs, and Tedeschi, "Mechanical Propulsion from Unsymmetrical Magnetic induction Fields", *AIAA 95-2643*, Joint Propulsion Conference, San Diego, CA (1995).
- [15] Fralick G. and Niedra, "Experimental Results of Schlicher's Thrusting Antenna," *AIAA-2001-3657*, Joint Propulsion Conference, Salt Lake City, UT (2001).
- [16] Maly, J., & Vavra, J., "Electron Transitions on Deep

- Dirac Levels, I and II", *Fusions Technology*, 24 (1993), pp. 307-381, and 27, (1995) pp. 59-70.
- [17] Podkletnov E. and Nieminen, "A Possibility of Gravitational Force Shielding by Bulk YBCO Superconductor", *Physica C*, 203 (1992) pp. 441-444.
- [18] Robertson, G.A., "Exploration of Anomalous Gravity Effects by RF-Pumped Magnetized High-T Superconducting Oxides", AIAA-2001-3364, Joint Propulsion Conference, Salt Lake City, UT (2001).
- [19] Woodward, J.F., "A New Experimental Approach to Mach's Principle and Relativistic Gravitation", *Foundations of Physics Letters*, 3 (1990), pp. 497-506.
- [20] Woodward, J.F., "Measurements of a Machian Transient Mass Fluctuation", *Foundations of Physics Letters*, 4 (1991), pp. 407-423.
- [21] Woodward, J.F., "Method for Transiently Altering the Mass of an Object to Facilitate Their Transport or Change their Stationary Apparent Weights", US Patent # 5,280,864 (1994).
- [22] Woodward, J.F., "Mass Fluctuations, Stationary Forces, and Propellantless Propulsion," AIP Conference Proceedings, 504, STAIF, Albuquerque, NN, (2000), pp. 1018-1025.
- [23] Cramer, J., "Tests of Mach's Principle with a Mechanical Oscillator", AIAA-2001-3908, Joint Propulsion Conference, Salt Lake City, UT (2001).
- [24] Woodward, J.F., "Life Imitating 'Art': Flux Capacitors, Mach Effects, and Our Future in Spacetime," AIP Conference Proceedings, 699, STAIF, Albuquerque, NN, (2004), pp. 1127-1137.
- [25] Ringermacher, H. "An Electrodynamics Connection," *Class. Quantum Grav.*, 11 (1994), pp. 2383-2394.
- [26] Cassenti, B.N., and Ringermacher, "The How to of Antigravity," AIAA Paper 96-2788, Joint Propulsion Conference, Lake Buena Vista, FL, (1996).
- [27] Ringermacher, H., Conradi, Browning, and Cassenti, "Search for Effects of Electric Potentials on Charged Particle Clocks," AIAA-2001-3906, Joint Propulsion Conference, Salt Lake City, UT (2001).
- [28] Milonni, P. W., *The Quantum Vacuum*, Academic Press, San Diego, CA (1994).
- [29] Sparnaay, M. J., "Measurements of Attractive Forces between Flat Plates", *Physica*, 24 (1958), pp. 751-764.
- [30] Forward, R.L., "Extracting Electrical Energy from the Vacuum by Cohesion of charged Foliated Conductors", *Phys Rev B*, B30 (1984), pp. 1700-1702.
- [31] Cole, D.C. and Puthoff, "Extracting energy and heat from the vacuum", *Phys. Rev. E*, 48 (1993), pp. 1562-1565.
- [32] Corum, J.F., Keech, Kapin, Gray, Pesavento, Duncan, and Spadaro, "The Electromagnetic Stress-Tensor as a Possible Space Drive Propulsion Concept", AIAA-2001-3654, Joint Propulsion Conference, Salt Lake City, UT (2001).
- [33] Bulmer, J.S., & Lawrence, T., "Interferometer Examination of the Time Derivative of Electromagnetic Momentum Created by Independent Fields and Applications to Space Travel", USAFA TR 2003-03, (2003) United States Air Force Academy, Colorado Springs, CO.
- [34] Brito, H.H., "Experimental Status of Thrusting by Electromagnetic Inertia Manipulation", Paper IAF-01-S.6.02, 52nd International Astronautical Congress, Toulouse France (2001).
- [35] Feigel, A., "Quantum Vacuum Contribution to the Momentum of Dielectric Media", *Physical Review Letters*, 92 (2004 January 16), pp. 020404-1 to 020404-4.
- [36] Rueda, Haisch and Cole, "Instability in Astrophysical Plasmas and the Formation of Cosmic Voids," *Astrophysical Journal*, 445 (1995), pp. 7-16.
- [37] Ibisson, M. and Haisch, "Quantum and classical statistics of the electromagnetic zero-point-field", *Physical Review A*, 54 (1996), pp. 2737-2744.
- [38] Haisch and Rueda, "Reply to Michel's OComment on Zero-Point Fluctuations and the Cosmological Constant O", *Astrophysics. Journal*, 488 (1997), p. 563.
- [39] Rueda and Haisch, "Inertial mass as reaction of the vacuum to accelerated motion", *Phys. Letters A*, 240 (1998), pp. 115-126.
- [40] Rueda and Haisch, "Contribution to inertial mass by reaction of the vacuum to accelerated motion," *Foundations of Physics*, 28 (1988), pp. 1057-1108.
- [41] Puthoff, Little and Ibisson, "Engineering the zero-point field and polarizable vacuum for interstellar flight", *Jour. Brit. Interplanetary Soc. (JBIS)*, 55 (2002), pp. 137-144.
- [42] Park, R.L., *Voodoo Science: The Road from Foolishness to Fraud*, Oxford University Press (2001).
- [43] Li, Noever, Robertson, Koczor, and Brantley, "Static Test for a Gravitational Force Coupled to Type II YBCO Superconductors", *Physica C*, 281 (1997), pp. 260-267.
- [44] Hathaway, Cleveland, and Bao, "Gravity modification experiment using a rotating superconducting disk and radio frequency fields", *Physica C*, 385 (2003), pp. 488-500.
- [45] Podkletnov, E., and Modanese, "Impulse Gravity Generator Based on Charged YBa₂Cu₃O_{7-y} Superconductor with Composite Crystal Structure," arXiv:physics/0108005 v2, (30 Aug 2001).
- [46] Bertolami, O., and Tajmar, "Gravity Control and Possible Influence on Space Propulsion: A Scientific Study", ESA CR (P) 4365, on Contract ESTEC 15464/01/NL/Sfe (2002).
- [47] Anderson, J.D., et.al., "Indication from Pioneer 10/11, Galileo and Ulysses Data of an Apparent Anomalous Weak Long-range Acceleration", *Phys Rev Let*, 81 (1998), p. 2858-2861; and response to comments in *Phys Rev Let*, 83 (1999), p. 1891.
- [48] Tajmar, M. & de Matos, C.J., "Gravitomagnetic Field of a Rotating Superconductor and a Rotating Superfluid", *Physica C*, 385 (2003) p. 551-554.
- [49] Szpak, S., and Mosier-Boss, (eds), "Thermal and Nuclear Aspects of the Pd/D₂O System, Volume 1: A Decade of Research at Navy Laboratories", Technical Report 1862, SPAWAR Systems Center, San Diego, CA. (Feb-2002).
- [50] Brown, T.T., "A Method of and an Apparatus or Machine for Producing Force or Motion", GB Patent #300,311 (1928).
- [51] Campbell, J.W., "Apparatus and Method for Generating Thrust Using a Two Dimensional, Asymmetrical Capacitor Module", US Patents 6,317,310 (2001) and 6,411,493 (2002).
- [52] Talley, R. L., "Twenty First Century Propulsion

- Concept", PL-TR-91-3009, Final Report for the period Feb 89 to July 90, on Contract FO4611-89-C-0023, Phillips Laboratory, Air Force Systems Command, Edwards AFB, CA (1991).
- [53] Tajmar, M., "Experimental Investigation of 5-D Divergent Currents as a Gravity-Electromagnetism Coupling Concept", AIP Conference Proceedings, 504, STAIF, Albuquerque, NM, (2000), pp. 998-1003.
- [54] Tajmar, M., "The Biefeld-Brown Effect: Missinterpretation of Corona Wind Phenomena", AIAA Journal, 42, (2004), pp. 315-318.
- [55] Canning, F.X., Campbell, J., & Winet E., "The ISR Asymmetrical Capacitor Thruster; Experimental Results and Improved Designs", Planned for the 40th AIAA/ASME/SAE/ASEE Joint Propulsion Conference and Exhibit, Fort Lauderdale, FL (July 2004).
- [56] Morris, M. S., Thorne, and Yurtsever, "Wormholes, time machines, and the weak energy condition", Physical Review Letters, 61 (1988), p. 1446.
- [57] Morris, M.S., and Thorne, "Wormholes in spacetime and their use for interstellar travel: A tool for teaching general relativity", American Journal of Physics, 56 (1988), pp. 395-412.
- [58] Hochberg, D., and Kephart, "Lorentzian wormholes from the gravitationally squeezed vacuum", Physics Letters B, 268 (1991), p. 377.
- [59] Visser, M., Lorentzian Wormholes: from Einstein to Hawking, AIP Press, New York (1995).
- [60] Visser, M., Kar, and Dadhich, "Traversable wormholes with arbitrarily small energy condition violations", Physical Review Letters, 90 (2003), p. 201102.
- [61] Alcubierre, M., "The warp drive: hyper-fast travel within general relativity," Class. Quantum Gravity, 11, (1994), p. L73.
- [62] Pfenning, M.J., and Ford, "The unphysical nature of warp drive", Class. Quantum Gravity, 14 (1997), p. 1743.
- [63] Krasnikov, S.V., "Hyperfast Interstellar Travel in General Relativity", Phys. Rev. D, 57 (1998), p. 4760.
- [64] Van Den Broeck, C., "A 'warp drive' with more reasonable total energy requirements", Class. Quantum Grav, 16 (1999), p. 3973.
- [65] White, H., "A Discussion of Space-Time Metric Engineering", General Relativity and Gravitation, 35 (2003), pp. 2025-2033.
- [66] Bennett, G.L., Forward, and Frisbee, "Report on the NASA/JPL Workshop on advanced quantum/relativity theory propulsion", AIAA Paper 95-2599, Joint Propulsion Conference (1995).
- [67] Cramer, J., Forward, R.L., Morris, M., Visser, M., Benford, G. and Landis, G., "Natural Wormholes as Gravitational Lenses", Physical Review D, (March 15, 1995), p. 3124-3127.
- [68] Barish, B. and Weiss, "LIGO and the Detection of Gravitational Waves," Phys. Today, 52 (1999), pp. 44-50.
- [69] Baker Jr. R., "Precursor Proof-of-Concept Experiments for Various Categories of High-Frequency Gravitational Wave (HFGW) Generators", AIP Conference Proceedings, 699, STAIF, Albuquerque, NN, (2004), pp. 1093-1097.
- [70] Woods, R. C., "Review of Claims of Interaction Between Gravitation and High-Temperature Superconductors", AIP Conference Proceedings, 699, STAIF, Albuquerque, NN, (2004), pp. 1085-1092.
- [71] Smith, P.D., and Vinogradov, "Microwave Thrust Mechanism", AIAA 2001-3802, Joint Propulsion Conference, Salt Lake City, UT (2001).
- [72] Tucker, R.W. and Clark, "Gauge Symmetry and Gravitoelectromagnetism", Quantum Gravity, 17 (2000), p. 4125.
- [73] Burton D., et al., "Towards the Control of Matter with Gravity", AIAA -2001-3912, Joint Propulsion Conference, Salt Lake City, UT (2001).
- [74] Tucker, R.W., et al., "On the Motion of Spinning Test Particles", Class. Quant. Grav., 18 (2001), p. 3007.
- [75] Tucker, R.W., and Dereli, "A Broken Gauge Approach to Gravitational Mass", J. High Energy Phys., JHEP 03 (2002), p. 042.
- [76] Tucker, R.W., et.al., "On the Detection of Scalar Field induced Spacetime Torsion", Mod. Phys. Lett., A17 (2002), p. 421.
- [77] Speake, C.C., and Trenkel, "Forces between Conducting Surfaces due to Spatial Variations of Surface Potential", Physical Review Letters, No. 160403 (25 April 2003).
- [78] Allen, J.E., "Quest for a Novel Force: A possible Revolution in Aerospace", Prog. Aerospace Sci., 39 (2003), p. 1.
- [79] Puthoff, H. E. "Gravity as a zero-point-fluctuation force", Phys. Rev. A, 39 (1989), p. 2333; Comments, Phys. Rev. A, 47 (1993), p. 3454.
- [80] Puthoff, H. E., "On the source of vacuum electromagnetic zero-point Energy", Phys. Rev. A, 40 (1989), p. 4857; Errata and Comments, Phys. Rev. A, 44 (1991), pp. 3382-3385.
- [81] Haisch, B., Rueda, and Puthoff, "Inertia as a zero-point field Lorentz force", Phys. Rev. A, 49 (1994), p. 678.
- [82] Puthoff, H. E., "Polarizable-Vacuum (PV) approach to general relativity", Found. Phys., 32 (2002), pp. 927-943.
- [83] Haisch & Rueda, "The Case for Inertia as a Vacuum Effect: a Reply to Woodward & Mahood," Physics Letters A, 268 (2000), p. 224.
- [84] Dobyns, Rueda & Haisch, "The Case for Inertia as a Vacuum Effect: a Reply to Woodward & Mahood," Foundations of Physics, 30 (2000), p. 59
- [85] Modanese, G., "Large ODipolar Vacuum Fluctuations in Quantum Gravity," Nucl. Phys. B, 588 (2000), p. 419.
- [86] Modanese, G., "The Paradox of Virtual Dipoles in the Einstein Action," Phys. Rev. D, 62 (2000), p. 087502.
- [87] Cole, D.C., Rueda, Danley, "Stochastic nonrelativistic approach to gravity as originating from vacuum zero-point field van der Waals forces," Phys. Rev. A, 63 (2001), p. 054101.
- [88] Haisch, Rueda & Dobyns, "Inertial mass and the quantum vacuum fields," Annalen der Physik, 10 (2001), pp. 393-414.
- [89] Walker, Robert S. (2002), Final Report of the Commission on the Future of the United States Aerospace Industry, Arlington VA, p. 9-6. [<http://www.aerospacecommission.gov/>]
- [90] Scott, W, "To The Stars: Zero point energy emerges from realm of science fiction, may be key to deep-space travel", Aviation Week & Space Technology, (1 March 2004), pp. 50-53.

Direct Conversion of Magnetic Field of Constant Magnets Energy and Its Application In Power Engineering and Mechanics

Valery D. Dudishev, Russia, Samara
The Samara Technical University
ecology@samaramail.ru

Global and ever increasing energetic and ecological crises of the Earth prompt scientists and engineers to scan for new alternative, pollution-free sources of energy, among them based on constant magnets and electrets [1-4]. The well-known magnetic engines (ME) by Serl, Minato and Floyd are unfortunately not perfect, but they marked the beginning of ME history and development [1]. The article lists original designs of new, totally non-current ME. In spite of the fact, that magnetic nature has not been totally solved yet, constant magnets are really bringing us to revolution in energetic and mechanics. Huge headway in the sphere of constant magnets permits us to anticipate in the not too distant future the creation of magnetic motor generators and other useful devices based on their principles, with capacity up to 100- 200 kW.

Non-contact Magnetic Rotational Bearing of Rotation

Bearings are the most widespread and important element of many devices, ranging from a motorcar to a spaceship and rocket. However, the mechanical bearings have practically exhausted their potentialities. They wear out rapidly, need regular maintenance and are short-lived. Moreover, mechanical bearings have a limitation on speed of rotation and reliability that limits the area of their usage. There are electromagnetic non-contact rotational bearings. Still they are rather complicated and expensive devices. Headway in updating the properties of constant magnets allows creating a high-capacity, simple in design and totally non-contact magnetic bearing. Fig. 1 illustrates its structure. Force repulsion of

cylindrical magnets 2, 3 compensates the loads on shaft 6 on radial axis. Force repulsion of end magnets 4, 5 from stator and rotor magnets 2, 3 compensates axial loads of the bearing. As a result we have a self-balancing, totally non-current magnetic dynamic system of non-contact shaft suspension 6. Such a progressive and prospective application of constant magnets allows creating a cheap non-contact bearing, simple in design, with no outage and with unlimited economic life.

To simplify the draft, Fig. 1 doesn't show some small parts of the magnetic bearing.

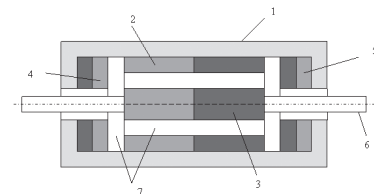

Fig.1. Totally magnetic rotational bearing.

1. Non-magnetic case of the magnetic bearing
2. Constant magnet of the stator as an axially oriented quill cylinder
3. Constant magnet of the rotor
4. Left back-up annular disk magnet
5. Right back-up annular disk magnet
6. Magnetic bearing shaft
7. Working air clearances

The main distinctive feature of this simple and elegant engineering solution is the unique combination of magnets along the two coordinate axes to automatically compensate axial and radial load on the shaft of the bearing. If high-tech is applied to create a precise model of such a non-contact suspension, observing the minimal clearances of a split millimeter width between the magnets and if modern magnets

like “samarium- cobalt” are used, such magnets can really be used in dynamic conditions of shaft loads in motor transport up to 200 kW of mechanical capacity.

Magnetic Reducers

Modern multi-stage reducers are applied everywhere, in many fields of technique, ranging from motor transport to kitchen units. Meanwhile they are rather complicated and expensive mechanical devices. Up-to-date constant magnets and their force interaction enable us to create a totally new energy saving type of non-contact new generation reducer. Let us consider them.

The fundamental property and condition of force interaction of one/ many magnetized bodies (e.g., constant magnets) is their tendency to be drawn by antipoles and their tendency to mutual immobility of their poles in space. Reduction of speed of two magnets with different poles, controlling and controlled, is a consequence of this effect. To prove this fact one should assembly a simple magnetomechanic plant, shown in Fig.2.

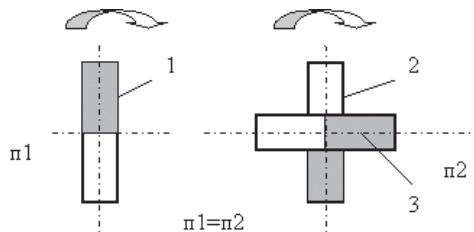

Fig. 2. Magnetic reduction of speed effect

When the elementary magnetic bar 1 is rotated, the angular velocity of compound magnet 2, 3 rotation is twice as smaller as magnet 1 rotation speed, as only in this case the magnetic fields of these unbound magnets are mutually immobile in space. Yet this device is a simplest magnetic reducer of speed.

Dudyshev’s Magnetic Disk Reducer

Fig. 3 illustrates a more effective magnetic disk reducer designed for a non-contact transmission of considerable turning moment from drive shaft to driven shaft:

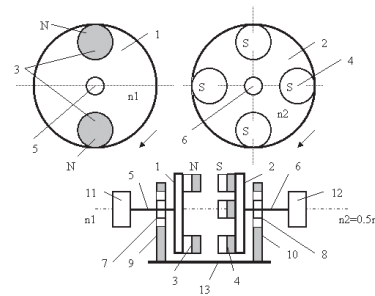

Fig. 3 Dudyshev’s magnetic disk reducer

- A – installation of magnets on disks
- B – structure of magnet reducer
- 1. driving disk
- 2. driven disk
- 3. constant magnets of the driving disk (north magnetic pole N is above)
- 4. constant magnets of the driven disk (south magnetic pole S is above)
- 5. drive shaft of the magnetic reducer
- 6. driven shaft of the magnetic reducer
- 7. drive shaft bearing
- 8. driven shaft bearing
- 9. left supporting pole
- 10. right supporting pole
- 11. drive actuating mechanism
- 12. driven actuating mechanism
- 13. base

It consists of 2 parallel disks 1 and 2, fabricated from any non-magnetic material, working potent constant magnets 3 and 4, installed on these disks with their antipoles towards each other. The speed reduction ratio of the drive and the driven shafts 5 and 6 of the non-contact reducer is set in the ratio of the number of magnets on the disks. Due to minimal working clearances between the working magnets, this device can be applied in non-contact power gear boxes in motor transport of new generation on in other devices.

Besides, the performance index of such a magnetic reducer practically equals 1. Even now it’s possible to create compact non-contact magnetic reducers, capacity ranging from hundreds of W to 60 kW, as the force of attractive interaction of up-to-date magnets made of alloys like “samarium- cobalt” within a split millimeter reaches thousands of newtons. With further developed magnetic materials and constant magnets a magnetic reducer can transfer up to 100- 150 kW of mechanical power.

This power range of reducers is characteristic of mechanical reducers in motor transport. One can adjust speed in this reducer by various ways, for example, changing the number of constant magnets on the disks by electromagnetic and centrifugal governors, or by shielding a part of magnets and other ways to change magnetic attraction of the reducer disks.

Due to the fact that there are no friction parts in the magnetic reducer (MR), there is practically no mechanical friction loss, and, as a result, there's no runout of working parts and its economical life will be many times longer than that of the up-to-date mechanical reducers- they need practically no maintenance, there is no oil, no noise and vibrations. The design and projection of such a mechanical reducer is reduced to the choice of the overall dimensions of disks and reducer itself, and the choice of the type and number of disks to provide transmission of turning moment from the drive shaft to the driven, with the minimal possible clearance.

Depending on the objective to reduce speed according to a definite law of capacity, moment and speed regulation, one should choose a method of magnet number regulation (increase or decrease) on one of the MR disks. It is also possible to combine the functions of a magnetic bearing and a reducer in one structure. In this case a combined magnetic reducer-bearing is installed with independent shafts, and rotation speed of the output shaft is reduced by analogy, for instance, with a magnetic disk reducer.

Totally Magnetic Engines

Perpetual motion and totally magnetic engines (ME) of this kind, which transfer magnetic field energy of constant magnets into their mutual rotation and travel over one cycle, that is into kinetic energy of their mutual motion has been a dream of humanity for a long time. It's quite clear, that such ME will lead to the energetic revolution in the mankind. Projects and developments of such ME structures has been carried in the world in the course of some centuries. However, a totally magnetic motor hasn't been constructed, as far as I know. Magnetolectric motors designed by Minato, a Japanese inventor, are unfortunately rather

complicated and still call for numerous devices to compensate thrusts; tracking loops for rotor magnets and energy expenses [2]. Is it possible to design simple, totally magnetic engines? – Yes, it is! Some new methods to transfer magnetic energy of constant magnets into mechanical energy of constant motion and some projects of simple, totally non-current ME, that were partially tested on simple physical models are given below.

Magnetic-Gravitational Engines

To begin with, one should examine methods of purely magnetic motors design and simplest magnetic-gravitational engines (MGE) – magnetic pendulums and rotation MGE design.

a) Magnetic pendulum

Fig. 4 gives a simplest pendular magnetic-gravitational engine with two magnets – fixed constant magnet 6 and mobile magnet 1, installed with its like pole on repulsion, minimal clearance in a hollow non-magnetic tube 3 with opposing spring 2 and rest 5.

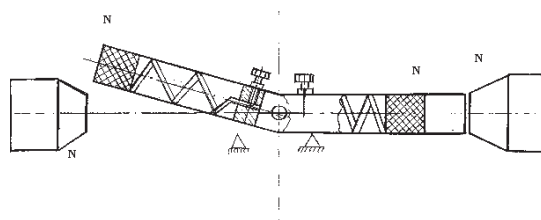

Fig. 4.

Under the action of like poles repulsion, the mobile magnet 1 starts to perform oscillation in vertical plane. The left-hand side of the draft shows elements of this simple “magnetic pendulum” magnetomechanic system in the upper point of the pendulum 3 rise due to magnetic fields energy of magnets 1 and 6 repulsion forces. At first the left-hand side rises with a hollow tube 2 and, repelling from magnet 6, simultaneously cocks the spring inside (the extreme position of magnet 1-1 and constricted spring 2-1 after the pendulum return to the lower point up to base 5.

Further, affected by gravity, the tube stoops, and when the spring straightens, the force of magnet

repulsion increases and the process cycles. Thus, the magnetic- gravitational device performs oscillatory and back-and-forth motion of the magnet 1 as to the magnet 6 combined, that is it converts magnetic energy into mechanical one.

b) Magnetic- Gravitational Engine Where Ball Magnets Are Rotated On the Rod

A more perfect structure of a magnetic-gravitational engine of rotation (MGE) is shown in Fig. 5.

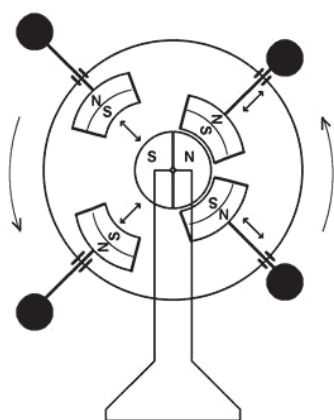

Fig. 5.

It is made up of a non-magnetic cylinder-rim 1, installed on the horizontal axis on a vertical base 6. On the outside of this axis and inside the rim 1 there is a cylindrical magnet 2, radially magnetized, where the acclinic line axis runs along the vertical line of the base 5. There is an arc constant magnet 3 inside the rim, the inner radius of which equals the outer radius of the magnet 2, on the moving radial axis 4, on the end of which there is a metal ball 5.

To increase the energetic efficiency of the motor, one shall install a spring energy storage device, set on axis 4 between the rim 1 and magnet 3. Fig. 5 doesn't show the spring. The number of spring-magnet rods can be more than one. In this case they are installed on rim 1 symmetrically. The structure like that will increase the motor's capacity, while the dimensions will stay constant. To start this MGE on should perform starting

rotation of rim 1 by the starting device. The motor will go on working autonomously. The rotor 1 rotation is conditioned by the fact, that the turning moment of the disk rotor 1 from the total force of gravity and force of magnetic repulsion of magnets on the left acceleration area of rim 1 is more than retarding torque with load 5 lift. As the radii of load 5 rotation are different due to the magnetic repulsion force of magnets 1 and 3 on the left half-turn of rim 1 (rod 4 moves forward).

On the return semicycle- halfturn of rim 1 magnets 2, 3 are attracted, that is why the radius and the turning moment of load 5 decrease on this interval. One can regulate the capacity and the speed of the rotor-rim 1 by turning the central cylindrical magnet 2 about its axis or by other ways, e.g. varying the working clearances between the magnets, by the rod 4 length. If magnets 2, 3 and the load ball 5 are selected correctly, the device will operate steadily. It can be developed in accordance with various capacities. The greater the field density of the constant magnets is and the greater their mass is- the greater is the mechanical capacity of this engine. Its area of application is rather wide: ranging from souvenirs to power non-fuel gears in many kinds of motor transport. If you install such a magnetic-gravitational engine on a flat floating platform and provide this rotor with blades, it will gather speed without any visible reason.

Mechanical capacity on the shaft of the blade cylinder MGE and the platform speed are yielded only by magnetic and gravitational energy of this unique motor, to be more exact – by attraction and repulsion pulse of the rotor magnets as to the stator magnets. Moreover, such a non-fuel MGE can simultaneously produce AC energy, if inductive windings are installed on the rim. It is natural that the total mechanical capacity and total energy produced by the motor-generator do not exceed capacity and energy of magnets-gravity forces interaction. They are in direct dependence of the MGE dimensions, magnets 2, 3 and load-ball 5 mass and properties.

c) Magnetic- Gravitational Engine "Magnetic Whirligig" Where Focal Plane Disk Is Rotated By the Screen-Segments and the Magnets Are Shifted In Vertical Plane

As it turned out, a whirligig- a well-known toy

can be transformed into a magnetic perpetual motion machine. This ME is shown in Fig. 6. To improve the gravity application in the MGE, we worked out a “magnetic whirligig” device, where constant magnets perform back-and-forth motion (Fig. 6).

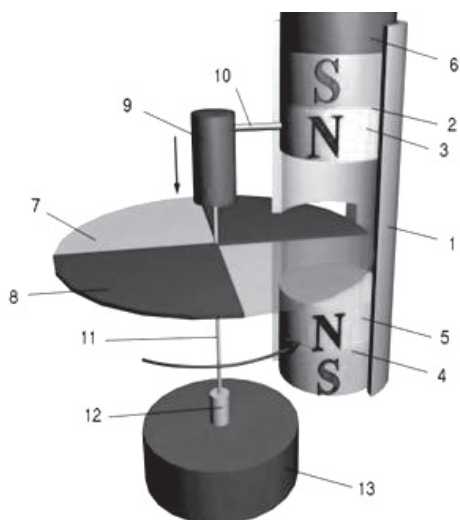

Fig. 6. A perpetual motion machine with rotating shutter

This MGE is made up of a horizontal disk 8, sectioned with magnetic screens 7 and a spring mechanism 9 installed on the vertical axis 11 and connected with a lever 10 to a mobile constant magnet 2, with load 6 set in a vertical non-magnetic tube 1; constant magnets 2, 4 are installed inside the tube with like poles 3, 5 set oppositely to repulse the upper mobile magnet 2 from the fixed lower magnet 4.

The principle of this MGE operation is in the following: magnet 2 moves upward under the action of magnetic repulsion forces of magnet 4 if there is no shutter 7 between them.

And vice versa – during the next ME semicycle magnet 2 moves down under the action of gravity, if magnets 2, 4 are shielded with a shutter – screen 7- when a segment disk 8 is rotated. The disk moves like a whirligig, as the spring inside the cylindrical ring 9 compresses and decompresses cyclically when the lever 10 connected with a mobile

magnet 2 and a recoil spring inside the rim 9 performs back-and forth motion.

The rotation velocity of the disk depends on the MGE design factor, on the constant magnets mass and properties. One can install an electric generator 12 on axis 11. The advantage of these MGEs is valid usage of magnetic forces of repulsion in constant magnets.

Polar Magnetic Orbital Engines

Let us consider another method to directly convert magnetic energy alone of constant magnets (CM) into mechanical energy of their interrotation with heterogeneity of their magnetic fields on magnetic poles and aclinic lines of there CM. The most typical designs of such polar MEs are depicted in Fig. 7- 9. Experimentally, due to magnetic field heterogeneity of the central stator magnet and the rotor magnet, due to the rotor magnet moment of inertia and perpetual attraction-repulsion forces interchange on various parts of the constant rotor magnet trajectory, all these polar ME devices proved to be quite efficient.

a) ME With a Mobile Rotor Magnet In the Axis Plane

When the CM of the rotor 2 and the rim 3 are initially set between aclinic line and the constant stator 1 magnet, when its poles are initially oriented on interattraction to the opposite magnetic pole of the central fixed stator magnet and after the initial impulse of the rotor magnet 2 towards the closest magnetic pole of the central magnet 1, the mobile rotor- magnet 2 starts to accelerate spontaneous axial and orbital rotation around the central fixed constant magnet 1 in the upper dead point.

It mechanically passes the area above the magnetic pole of the central CM and, with its lines of force, repulses from the like pole of the stator 1 magnet. Having passes the aclinic line, CM 1 takes a 180° turn. Experimentally, the mobile magnet 2 can sometimes perform mechanically four or more axial turns on the axis of the base 4 during its full orbital turn.

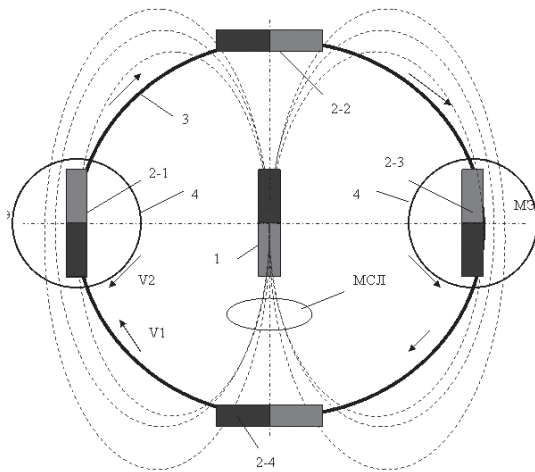

Fig. 7. Magnetic orbital engine with interrelated axial and orbital rotation of inverted rotor magnet

1. Central fixed constant magnet
 2. Mobile constant magnet of axial and orbital rotation
 3. Rim- ring of magnet 2 rotation round the magnet 1
 4. Axial rotation platform of magnet 2
- MΘ – acclinic line
 MCJI – magnetic lines of force of magnet 1
 Blue color – north pole of magnets
 Red color – south pole of magnets
 V1 – orbital velocity of magnet 2 rotation round the magnet 1
 V2 – axial velocity of magnet 2

However, we noticed an inevitable effect: having passed the fixed magnet 1 acclinic line, the magnet automatically swivels in space on the plane axis to be attracted to the closest pole of the central CM with its antipole along the trajectory of its orbital rotation with rim 3.

As a matter of fact, this is a simplified physical model of a natural magnetic motor in the solar system (interrelated spontaneous axial and orbital rotation of constant magnet as to the central constant magnet).

b) Orbital Magnetic Engine With a Central Compound Magnet (Quasimonopole) and an Orbital Mobile Magnet

This is the first device of a totally non-contact ME with a compound magnet, quasimonopole of the inverted stator. That is why the rotor magnet 2 is rigidly oriented on rim 3 as a tangent to it.

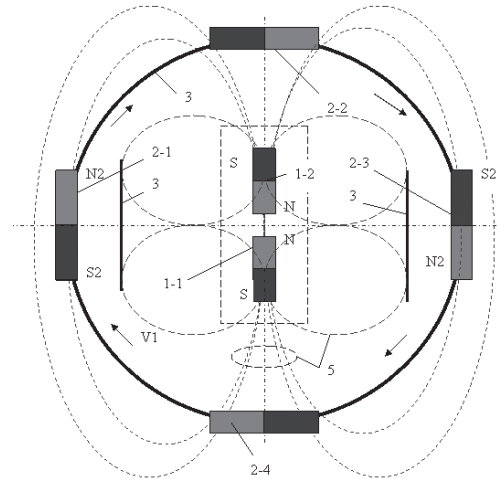

Fig. 8. Magnetic engine with a compound magnet- quasipole in the centre

1. Compound magnetic quasipole (2 fixed constant magnets 1-1 and 1-2 are installed oppositely)
 2. Mobile constant magnets
 3. Rotor with rigidly fixed magnets 2
 4. Magnetic shields
 5. Magnetic lines of force of magnet 1
- ME – acclinic line
 VI – linear velocity of magnet 2 rotation around magnet 1

Having analyzed the interaction of magnetic forces of the mobile magnet of the rotor 2 with the total magnetic pole of the stator quasimonopole 1 in such ME, we came to the conclusion that there is a permanent accelerating force of the magnet 2 on every part of its orbit. Actually, the rotor magnet will accelerate from the point 2-1 of the acclinic line to the point of the magnetic pole of the quasimonopole 1. In the point of the rotor magnetic bar symmetrical installation, as Fig. 8 shows, above the pole of the central quasimonopole, obliquely and symmetrically to the polar axis of the quasimonopole, the force of their magnetic attraction will equal to zero, as both parts of the magnet 2 are set at one and the same distance to this pole of the quasimonopole.

It means, that the force interaction of the rotor magnet poles is also equal, but is opposite in sign. If the rotor magnet is mobile on the axis, it will turn with its antipole to the pole of the

quasimonopole 1, but it is rigidly fixed on the rim, and it will pass this pole of the magnet 1 mechanically (with the rim 3). But as soon as the rotor passes the polar point of the quasimonopole, the force of magnetic repulsion will act up to the point where it will cross the acclinic line of the quasimonopole 1. Then, as soon as the magnet 2 crosses the acclinic line (AL), the force of magnetic attraction will exert on the rotor magnet pole and the antipole of the magnetic monopole, due to the heterogeneous magnetic field of the monopole and closeness of magnetic lines of force in the area of its second magnetic field. That is, it will move to the antipole, to the area of the lines closeness.

Thus, this ME alternates the magnetic forces of attraction and repulsion. The attraction force of magnets 1,2 exerts from the point 2-1 up to the moment, where the rotor magnet 2 approaches the antipole of the quasimonopole.

This is the force of magnetic attraction to the area of magnetic lines closeness to the antipole of the quasimonopole. Moreover, the force is nonlinear and increases as soon as the magnet approaches the

pole of the quasimonopole along the rim trajectory and exerts in the area from the acclinic line to the pole of the quasimonopole. The force of repulsion exerts as soon as the rotor magnet crosses the magnetic pole of the quasimonopole.

This force of like poles repulsion exerts in the area from the pole up to acclinic line in the second part of the magnet 2 trajectory round the quasimonopole 1- in comparison with the initial point 2-1, and it is also nonlinear and reaches its maximum right after the magnetic pole of the magnet 1-1, then it decreases and equals zero on the acclinic line.

c) Orbital magnetic engine with quick and cheap effect magnetic reversal of the fixed stator CM with a rectangular loop of hysteresis (effect of magnetic trigger or Barkhausen effect), Fig. 9.

If feedback is introduced, the device can operate in totally automatic regime of motor-generator in a self-locked inductive magnetic system.

It is possible to add generator inductive windings on the stator magnets in the ME according to the drafts (Fig. 6- 8).

Thus, all the magneto-mechanical devices can operate simultaneously in mobile and generating regimes.

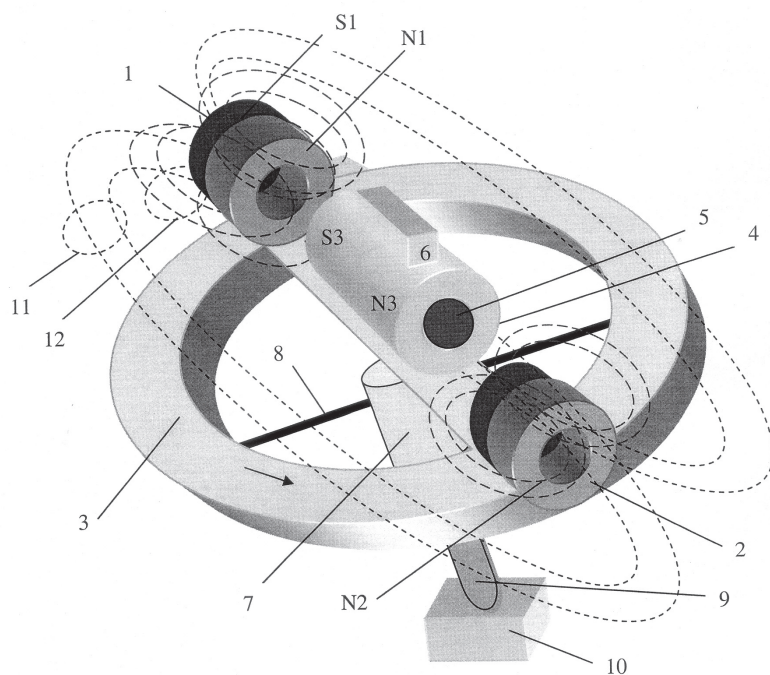

Fig. 9

1. Permanent magnet
2. Permanent magnet
3. Non-magnetic rotor
4. Solenoid-stator
5. Central permanent magnet
6. Commutator
7. Bearing mount assembly
8. Radii
9. Axis of rotation
10. Stand
11. Magnetic lines of force of the central magnet 5
12. Magnetic lines of force of the constant magnets 1, 2

On Physical Essence of Magnetic Energy Conversion In Magnetic Engines

In these MEs direct conversion of constant magnets' magnetic energy into mechanical energy of rotation does not violate the energy conservation law in the open energy system – a kind of an energy pump of physical vacuum. This is a result of ordered and unidirectional interaction of ether energy with ferromagnets. Due to the ordered structure of ferromagnets and their interaction through the force influence of rotor and stator ME fields including the mutual arrangement of the constant magnets, there arise conditions for intake-locking and conversion of ether energy through the magnets interaction into the ME mechanical yield.

Really, every electron and proton of any substance interact with physical vacuum and they have sink and source of ether [4].

In common materials the electron and proton spins are directed chaotically. When magnetized, they become parallel in magnetic domains. Magnetic properties of material increase if the protons and electrons of the substance dominate in one position.

This effect helps to create an ordered ether stream through the constant magnets and the ether vortex round the ME. As the ME rotor is mobile, the ether pressure involves it into rotation in the line of the ether vortex. Maximal pressure of the ether stream on the rotor is achieved when the bodies are totally magnetized, e.g. if the protons and electrons are arranged in one direction. As a result, there appear vigorous input and output ether streams. It involves pressure energy of the gaseous ether, like tornado is supported by the pressure of the Earth atmosphere. This energy of the ether pressure on the magnetic bodies rotates the ME rotor magnet in relation to the fixed stator magnet if they are installed properly and it provides the closed loop of the suggested magnetic engines- generators.

The ME structures are depicted only foreshortened and simplified. The essence of its performance is identical to the ME in Fig. 8. To increase the constant magnets interaction force

along the magnetic lines of force it is necessary to install additional magnetic conductors, special forms of magnets and minimal clearances between them.

Summary

1. Totally magnetic bearing, magnetic disk reducer and totally magnetic engines of various kinds have been suggested and considered for the first time.
2. For the first time there have been suggested methods to convert magnetic and gravitational energy by a single structure of magnetic magnets, working over one cycle, and various structures of magnetic- gravitational engines of different types (oscillatory, rotational).
3. The structures of magnetic engines, non-contact magnetic reducers and bearings offer the challenge to non-fuel and efficient magnetic power engineering and mechanics.
4. The suggested polar magnetic engines can be applied in automatics to design a “permanent” orbital magnetic satellite of the Earth – a native magnet – and of other planets, possessing magnetic fields [2].
5. The suggested magnetic power engineering and mechanics is an efficient way to improve the world power engineering and solve the problems of global ecology. It will enable us to create new clean energy- saving technologies in power engineering, industry, transport and will permit us in prospect to eliminate the ecologically harmful thermoelectric power stations like APP and heat power plants.

References:

1. Commercialization of the Searl's effect in power engineering and in the area of new propulsion systems, review, *New Energy Technologies*, No 2, 2004.
2. V. D. Dudyshev, *New Fuelless Space Power Engineering*, *New Energy Technologies*, Dec. 2002.
3. V.D. Dudyshev, *Latent Potential Energy of Electrical Field*, *New Energy Technologies*, July 2003.
4. V.D. Dudyshev, *Method of Internal Energy Extraction From Substances*, *New Energy Technologies*, No 3, 2004.

High Efficient Electrostatic energy field power generating system

Hyde William W. (1685 Whitney, Idaho Falls, ID 83402, USA)
Appl. No.: 211704 Filed: June 27, 1988

Editorial: We are publishing here description of Wiliam Hyde's invention that is very useful for any invetor who is designing high efficient electrostatic generators. By opinion of experts W. Hyde reach a very good results: only 10% of the output power was necessary to provide work of motor and 90% of output power can be used for the load of this generator. The lawyer Ronald D. Cohn wrote in his letter of Nov.18 1991 about non-exclusive license deal. The price was mentioned as 5.5 mil USD plus 2 USD for each device (visit KeelyNet for more info about this invention).

Abstract

Externally charged electrodes of an electrostatic generator induce charges of opposite polarity on segments of a pair of confronting stators by means of electric fields within which a pair of rotors are confined during rotation to vary the charge binding field linkages between confronting rotors and stators by a shielding action of the rotors in a plane perpendicular to the field flux. A high electric potential difference induced between the stators resulting from such rotation of the rotors, is transformed by an output circuit into a reduced DC voltage applied to a load with a correspondingly increase current conducted therethrough.

Claims

What is claimed is:

1. An energy conversion system including a pair of electrodes maintained electrostatically charged at substantially equal potentials of opposite polarity, stator means mounted in operatively spaced relation to said electrodes for inducement therein of charges of opposite polarity through electric fields established by said equal potentials, power driven rotor means continuously disposed within said electric fields for receiving charged induced by said electric fields, means electrically connecting said rotor means to the stator means for equalizing of said

induced charges therebetween, field linkage control means for movably shielding the stator means from the electric fields during rotation of the rotor means and output circuit means operatively connected to the stator means for extracting therefrom an operating voltage in response to movement of said shielding of the stator means.

2. The system as defined in claim 1 wherein said stator means includes a pair of axially spaced stator discs respectively linked electrostatically to the electrodes by said electric fields, the rotor means including a pair of rotor discs respectively disposed axially between the electrodes and the stator discs.

3. The system as defined in claim 2 wherein said field linkage control means comprises angularly spaced segments on the rotor discs having charged faces shielding portions of the stator discs from the electrodes.

4. The system as defined in claim 3 wherein each of the stator discs includes angularly spaced surface portions confronting the angularly spaced rotor segments and dielectric means between said surface portions for confining the induced charges thereto, the surface portions of the stator discs and the charged faces of the rotor segments being unequal in area.

5. An energy conversion system including a pair of electrodes electrostatically charged to substantially equal potentials of opposite

polarity, stator means mounted in operatively spaced relation to said electrodes for inducement therein of charges of opposite polarity through electric fields established by said equal potentials, said stator means including a pair of axially spaced stator discs respectively linked to the electrodes by said electric fields, power driven rotor means continuously disposed within said electric fields for receiving induced charges thereon, means electrically connecting said rotor means to the stator means for transfer of said induced charges therebetween, said rotor means including a pair of rotor discs respectively disposed axially between the electrodes and the stator discs and field linkage control means for variably shielding the stator means from the electric fields during rotation of the rotor means, said field linkage control means comprising angularly spaced segments on the rotor discs having charged faces shielding portions of the stator discs from the electrodes, each of the stator discs including angularly spaced surface portions confronting the angularly spaced rotor segments and dielectric means between said surface portions for confining the induced charges thereto, the surface portions of the stator disc having areas twice that of the areas of the charged faces of the rotor segments and output circuit means operatively connected to the stator means for establishing an operating voltage in response to said variation in the shielding of the stator means by the rotor means.

6. The system as defined in claim 5 including a power shaft assembly on which the rotors are mounted for simultaneous rotation, said electrical connecting means being formed by electrically conductive sections of said shaft assembly.

7. The system as defined in claim 6 wherein the charged faces of the rotor segments on one of the rotors is formed by dielectric material within which the induced charges of negative polarity are confined in stable ion form.

8. The system as defined in claim 7 wherein said output circuit means includes a pair of dc voltage terminals, a capacitive network, and current blocking diode means coupling the network to the terminals and to each of the surface portions of the stator discs for

multiplying current conducted between the stator discs while reducing potentials therebetween to a value equal to the operating voltage across the dc voltage terminals.

9. The system as defined in claim 2 wherein each of the stator discs includes angularly spaced surface portions confronting the rotor and dielectric means between said surface portions for confining the induced charges thereto.

10. The system as defined in claim 9 wherein said output circuit means includes a pair of dc voltage terminals, a capacitive network, and current blocking diode means coupling the network to the terminals and to each of the surface portions of the stator discs for multiplying current conducted between the stator discs while reducing potentials therebetween to the operating voltage across the terminals.

11. The system as defined in claim 1 including a power shaft assembly on which the rotors are mounted for simultaneous rotation, said electrical connecting means being formed by electrically conductive sections of said shaft assembly.

12. The system as defined in claim 3 wherein the charged faces of the rotor segments on one of the rotors is formed by dielectric material within which the induced charges of negative polarity are confined in stable ion form.

13. The system as defined in claim 1 wherein said stator means and said rotor means respectively have faces confronting each of the electrodes, and dielectric surface means coating those of the confronting faces on which the charges of negative polarity are induced and maintained in a stable ion form for preventing eddy currents and charge leakage.

14. The system as defined in claim 1 wherein the stator means and the rotor means have faces continuously exposed to said electric fields on which the charges of negative polarity are induced, and stabilizer means for preventing leakage of the induced charges through said faces.

15. The system as defined in claim 14 wherein

said stabilizer means comprises dielectric material on said faces maintaining the negative charges therein in stable ion form.

16. In an energy conversion system having an electrode of one polarity maintained at an electrostatic potential, a stator and a rotor disposed within an electric field established between the electrode and the stator by said potential on the electrode, means mounting the rotor for rotation continuously within the electric field and means electrically interconnecting the rotor and the stator for equalizing electrostatic charges established thereon opposite in polarity to said one polarity, the rotor having charged surface means partially shielding the stator from the electric field for producing an electric potential on the stator in response to rotation of the rotor causing movement of the charges established by the unshielded electric field.

17. The system as defined in claim 16 wherein the stator includes means for confining electrostatic charges established to surfaces of greater total area than that of the charged surface means of the rotor.

18. The system as defined in claim 1 wherein said stator means is mounted in fixed parallel spaced relation to the electrodes and said rotor means is rotatable about a rotational axis perpendicular to said electrodes.

19. In an electrostatic generator having a pair of axially spaced electrodes with electric fields therebetween establishing corresponding capacitances, a power driven rotor and means for electrically interconnecting the rotor with one of the electrodes of said pair during rotation of the rotor, the improvement residing in means fixedly mounting both of the electrodes of said pair, said electric fields being established and maintained by means respectively applying charge producing potentials of substantially equal and opposite polarity to the other of the electrodes of said pair for cancellation of forces exerted by said electric fields on the rotor, means mounted by the rotor for partial shielding of said one of the electrodes from said electric fields and means responsive to rotation of the rotor for extracting an output voltage generated on said one of the electrodes by

movement of said partial shielding thereof during maintenance of the corresponding capacitances established by the electric fields.

Description

This invention relates to the generation of electrical power by conversion of energy from an electrostatic field.

The conversion of energy from a static electric field into useful electrical energy by means of an electrostatic generator is already well known in the art as exemplified by the disclosures in U.S. Pat. Nos. 2,522,106, 3,013,201, 4,127,804, 4,151,409 and 4,595,852. Generally, the energy conversion process associated with such prior art electrostatic generators involves the input of mechanical energy to separate charges so that a considerable portion of the output is derived from the conversion of mechanical energy.

It is therefore an important object of the present invention to provide an electrostatic generator in which electrical power is derived from the energy of static electric fields with a minimized input of mechanical power.

SUMMARY OF THE INVENTION

In accordance with the present invention, static electric fields are established between electrodes externally maintained at charge levels of opposite polarity and a pair of internal stator discs having segmental surfaces that are dielectrically spaced to confine thereon charges induced by the electric fields. A pair of rotor discs are rotated within continuous electric fields in planes perpendicular to the field flux to locationally vary the charge linkage established by the electric fields between the electrodes and stator discs. Such changes in charge linkage are effected by rotation of electrically conductive segments of the rotor angularly spaced from each other to partially shield the stator discs from the electric fields. The segments of each rotor disc have charged faces confronting the electrodes in its field to shield the stator disc over a total face area that is one-half the total area of the confronting segment surfaces on the stator disc to which the induced charges are confined. Charges on the rotors and stators are equalized by electrical

interconnections established through the rotor shafts. The stator discs are electrically interconnected with an electrical load through an output circuit transforming a high potential between the stator discs into a reduced dc voltage to conduct a correspondingly multiplied current through the load.

BRIEF DESCRIPTION OF DRAWING FIGURES

These and other objects and features of the present invention will become apparent from the following description taken in conjunction with the preferred embodiments thereof with reference to the accompanying drawings in which like parts or elements are denoted by like reference numerals throughout the several views of the drawings and wherein:

FIG. 2 is a side section view of an electrostatic generator embodying the system of FIG. 1 in accordance with one embodiment of the invention.

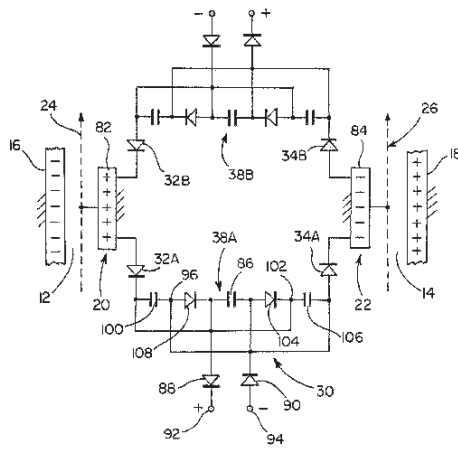
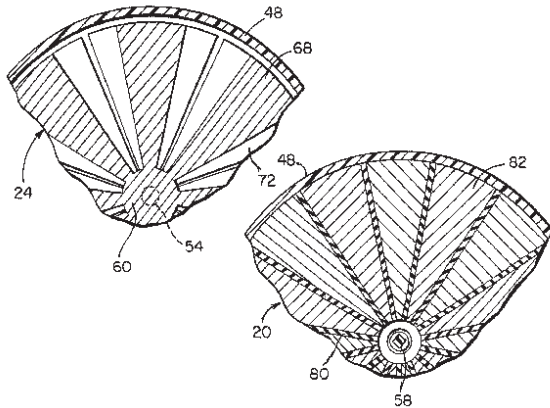

Fig.1

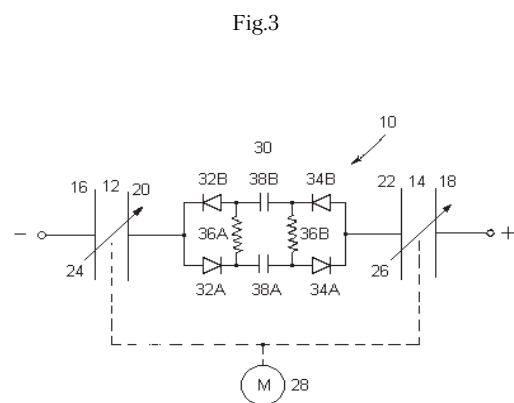

Fig.4

FIG. 1 is a simplified electrical circuit diagram corresponding to the energy conversion system of the present invention.

DETAILED DESCRIPTION OF PREFERRED EMBODIMENT

Referring now to the drawings in detail, FIG. 1 diagrammatically depicts the energy conversion system of the present invention generally referred to by reference numeral 10. As diagrammed in FIG. 1, the system includes a pair of electrostatic fields 12 and 14 established by electrostatic charges of opposite polarity applied to electrode plates 16 and 18 from some external energy source. Thus, the electrostatic field 12 is established between electrode 16 and a stator disc 20 while the electrostatic field 14 is established between electrode 18 and a stator

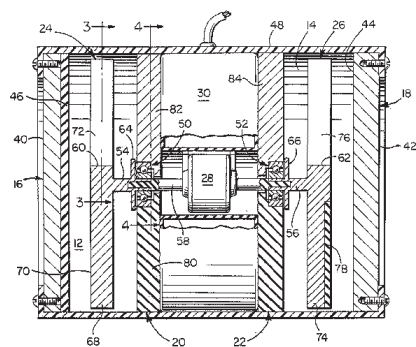

Fig.2

disc 22. In accordance with the present invention, electrostatic charge linkages established by the flux of the fields between the electrodes and stators are periodically varied by displacement within continuous energy fields 12 and 14 in response to rotation of rotors 24 and 26 aligned with planes perpendicular to their common rotational axis and the field flux as will be hereinafter described. The rotors are mechanically interconnected with an electric motor 28, as diagrammatically illustrated in FIG. 1, for rotation about the common rotational axis. Electrical energy may be extracted from the electric fields 12 and 14 during rotation of the rotors 24 and 26 by motor 28 through an output circuit generally referred to by reference numeral 30. The output circuit 30 as shown, in FIG. 1 in a simplified fashion, includes two pair of current conducting diodes 32A, 32B and 34A, 34B. The diodes of each pair are oppositely poled and each pair is connected in parallel to one of the stators 20 and 22. The diodes of each pair are also electrically connected across an electrical load represented by resistors 36A and 36B with capacitor networks 38A and 38B interconnected between each pair of diodes by means of which the voltage potential between the stators 20 and 22 is reduced in favor of an increased current through the electrical load.

Referring now to FIGS. 2, 3 and 4 in particular, a physical embodiment of the energy conversion system diagrammed in FIG. 1 is shown. The electrodes 16 and 18 are in the form of circular plates or discs made of an electrically conductive metal having external surfaces 40 and 42 adapted to be charged from the external source as aforementioned. The internal surface 44 of electrode 18 is thereby adapted to maintain a positive charge opposite in polarity to the negative charge of the electrode 16 which is maintained in a stable ion form within a dielectric surface portion 46 of the electrode 16. The energy conversion system may be enclosed within an outer housing 48 to which the electrodes 16 and 18 are secured.

With continued reference to FIG. 2, the stators 20 and 22 mounted by housing 48 in axially fixed spaced relation to the electrodes 16 and 18 are provided with bearings 50 and 52 establishing the aforementioned common

rotational rotor axis journaling a powered shaft assembly having electrically conductive shaft sections 54 and 56 to which the rotors 24 and 26 are respectively connected. In the embodiment illustrated in FIG. 2, the drive motor 28 is mechanically interconnected with the shaft sections 54 and 56 through an electrically nonconductive shaft section 58 of the power shaft assembly for simultaneous rotation of both rotors 24 and 26 at the same speed and in the same direction about the common rotational axis perpendicular to parallel spaced planes with which the electrode and stator discs are aligned. The electrically conductive shaft sections 54 and 56 are respectively keyed or secured in any suitable fashion to hub portions 60 and 62 of the rotors and are provided with flange portions 64 and 66 forming electrical wipers in contact with confronting surfaces of the stators 20 and 22, which are inductively charged by the static electric fields 12 and 14 to equal levels of opposite polarity.

As more clearly seen in FIGS. 2 and 3, the rotor 24 has a plurality of angularly spaced, field linkage controlling segments 68 projecting radially outwardly from the hub portion 60. Each rotor segment 68 is made of an electrically conductive metal having a face 70 on one axial side confronting the adjacent electrode 16. The faces 70 confronting the electrode 16 are charged positively by the electric field 12 extending between the dielectric surface portion 46 of electrode 16 and the stator disc 20. While the electric field 12 projects through the spaces 72 between the rotor segments 68, the rotor segments 68 themselves shield portions of the stator disc 20 from the electric field.

The rotor 26 is similarly formed with rotor segments 74 angularly spaced from each other by spaces 76 through which the electric field 14 extends between the positively charged surface 44 of electrode 18 and the stator 22. The rotor segments 74 of rotor 26 as shown in FIG. 2, are provided with dielectric surface portions 78 confronting the internally charged surface 44 of electrode 18. While the rotor segments 74 are negatively charged by the electric field 14 within the surface portions 78, they also shield portions of the stator disc 22 from the electric

field as in the case of the rotor segments 68 hereinbefore described. The internal dielectric surface portion 46 of electrode 16 and dielectric surface portions 78 of rotor 26 act as a stabilizer to prevent eddy currents and leakage of negative charge. Further, in view of the electrical connections established between the rotors and the stator discs, the charge on each stator is equalized with that of the charge on its associated rotor.

As shown in FIGS. 2 and 4, the stator disc 20 includes a plurality of segments 82 to which charges are confined, closely spaced from each other by dielectric spacers 80. The segments 82 are electrically interconnected with the rotor segments 68 through rotor shaft section 54. Similarly, the segments 84 of the stator 22 are electrically interconnected with the rotor segments 74 through rotor shaft section 56. The stator segments 82 and 84 are therefore also made of electrically conductive metal. Each of the segments 82 of stator 20 is electrically interconnected through the output circuit 30 with each of the segments 84 of the stator.

The foregoing circuit arrangement of capacitive network 38A is the same as that of network 38B by means of which aligned pairs of the stator segments 82 and 84 have the electrical potentials therebetween transformed into a lower voltage across the load terminals 92 and 94 to conduct a higher load current.

It will be apparent from the foregoing description that the electrostatic energy fields 12 and 14 of opposite polarity are established maintained between the externally charged electrodes 16 and 18 and the internally charged stators 20 and 22 under static conditions. During rotation, the rotors 24 and 26 continuously disposed within such energy fields 12 and 14, exert forces in directions perpendicular to the field flux representing the energy linkages between electrodes and stators to cause interruptions and reestablishment of energy linkages with portions of different stator segments. Such energy linkage locational changes and the charge binding and unbinding actions between electrodes and stators creates an electrical potential and current to flow between stators through the output circuit 30. Thus, the output circuit when loaded extracts

energy from the electric fields 12 and 14 as a result of the field linkage charge binding and unbinding actions induced by rotation of the rotors. The stator segments 82 and 84 shielded from the electric fields by the moving rotor segments 68 and 74, have electric potentials of polarity opposite to those of the external electrodes 16 and 18 because of the field linkage charge unbinding action. Previously shielded stator segments being exposed to the electric fields by the moving rotor segments, have the same electric potential polarity as those of the external electrodes because of field linkage binding action.

Since the forces exerted on the respective rotors by the electric fields 12 and 14 of opposite polarity act on the common rotor shaft assembly perpendicular to said fields, such forces cancel each other. The energy input to the system may therefore be substantially limited to mechanical bearing losses and windage during conversion of electrostatic field energy to electrical energy as well as electrical resistance losses and other electrical losses encountered in the output circuit 30.

Based upon the foregoing operational characteristics, rotation of the rotors in accordance with the present invention does not perform any substantial work against the external electric fields 12 and 14 since there is no net change in capacitance thereby enabling the system to convert energy with a reduced input of mechanical energy and high efficiency, as evidenced by minimal loss of charge on the electrodes.

It was therefore found that working embodiments of the present invention require less than ten percent of the electrical output energy for the mechanical input.

Further, according to one prototype model of the invention, a relatively high output voltage of 300,000 volts was obtained across the stators. By reason of such high voltage, an output circuit 30 having a voltage reducing and current multiplying attribute as hereinbefore described was selected so as to render the system suitable for many practical applications.

Vortex Propulsion Drive

History of the invention

Alexander V. Frolov

Faraday Lab Ltd, St.-Petersburg, Russia
7-812-380-3844 <http://www.faraday.ru> Email: office@faraday.ru

In August 2004 we have got negative answer from The Russian Patent Office on our patent claim #2002128658/06(030307) filled 25/10/2002. This invention describes a new propulsion non-reactive method and device. The idea is to transform rotational momentum into transverse kinetic force momentum. The negative answer from the patent experts was explained as impossibility to violate the third Newton law. They said that in our invention there is no reaction force. We tried to explain that in our method and device there is the reaction force but we have rotational momentum as reactive effect. But we failed to get patent. Now we are publishing this description and we hope that some of our readers can be interested to develop joint work with us on innovation and commercialization of this ideas.

Application of this invention is a new transport and military topic, for example, new carrier instead of the rockets.

The Field of the Invention

The invention is referred to means and devices to convert rotary motion of rotating medium along a special trajectory inside the device, into forward motion of the whole device and can be used to create propulsion systems and new means of transport.

Description of the Prior Art

As science and technique developed, they suggested different means and devices of exerting a driving force, which differ fundamentally from jet engines by the fact that they do not require jet rejection of mass beyond the device case to exert driving force. In 1926 G. Shifershtein acquired a patent No 10467 for transport, using oscillatory load. In 1934 M. Kolmakov in the inventor's

certificate No 45781 has described a carrier that needs no binding with the road, as it moves due to inertia. In 1961 S. Kuptsov and K. Karpuhin acquired the inventor's certificate No 151574 for a self-propelled system with eccentrics, which create centrifugal forces. The theoretical basis of these means, which is necessary to develop these technologies, continues nowadays and needs analysis of physical meaning of inertia, needs the development of inertial mass notion as a result of interaction with physical vacuum, which, in modern theories, is considered to be a peculiar medium. The example of the theory is a means and a device, described in the USA patent No 5280864 [1]. The devisers consider a method of short-period alteration of the objects mass, which occurs when the vibration process is combined with the charge- discharge of electric condenser, as development of the relativistic theory of gravity.

Some other engineering solutions describe ways of traction production due to the conversion of mass rotation into unilateral impulse or constant traction force. In most cases the devisers exert traction force in mechanical devices due to asymmetrical centrifugal (centripetal) force. In this case the non-compensated force is usually aimed radially in the plane of rotation to the gradient of the centrifugal force. This gradient is provided by constant or controlled alteration of the radius of rotation of solid/ liquid substance. For example, the summary of the invention (inventor's certificate No 589150) describes a way of the unbalanced centrifugal force exertion by means of the rotation radius alteration of the mass, rotating along the inner surface of the case.

The USA patent No 4631971 [2] describes a device with two diametrically set masses, each of them travels along a non-symmetrical trajectory, with

the altering distance to the rotation axis; as a result, there appears asymmetry of the centrifugal force in the plane of rotation. The USA patent No 5427330 [3] considers a similar device, where the radial attachment of the rotating mass automatically extends or shortens on the different areas of the trajectory that generates non-symmetric centrifugal force and provides the system motion as a whole. The USA patent No 5782134 [4] describes a tractive generator in which one-way traction in the plane of rotation is generated due to the controlled imbalance of the centrifugal force that makes it possible to exert a driving force in arbitrary direction, also in the plane of mass rotation.

The periodical tractive force, axially oriented, is exerted in the device [5], where the radius of rotation of the two symmetrical massive solid mediums changes periodically.

Solid rotating masses used as eccentrics limit the resources of the suggested systems because of the breaking point of the structure. There are other engineering solutions, using liquid as a working medium. [6]. The complexity of the system, that requires an intense magnetic field and a source of the electric field for magnetohydrodynamic effect limits the area of the patent application [6].

A similar method is described in the USA patent No 3979961 [7]. This method involves rotating liquid, which, in the certain place of its trajectory, hits a reflecting device and transfers its impulse to the case of the structure. As a result of an imbalanced centrifugal force, a constant tractive force exerts in the system. The effectiveness of this method is limited by a small amount of liquid, involved in the impulse transfer to the structure case during the interaction with a reflector.

In [8] Spartak Polyakov and Oleg Polyakov described a method and a device to exert axial tractive force with the altered radius of a gyroscope rotation, and they also published their experimental data. In accordance with this method, the working mass (the gyroscope) is set in rotary motion, and then the radius of rotation, being the controlled parameter of the working mass, is altered. When the radius of the working mass rotation is lowered, there appears a propulsive burn, directed along the axis of rotation. It is clear, that the alteration of the

working mass radius can be only periodical; therefore, the exerted tractive force has an impulse nature. When the working mass returns to original position, characterized by the maximal radius of rotation, the tractive impulse is nil.

There is a device, which converts rotary motion into forward motion in one direction; it is described in the Russian Federation certificate for a utility model No 20946 [9], which the closest in character to the applied invention.

The device consists of a case and a tool, connected with it to impart rotary motion to the working mass. The device is a converter of rotary motion into forward motion in one direction. The converter has a basic element of rotation that presents a tube in the form of a cone-shaped spring, a coaxial longitudinal axis of the device, a pump and liquid mercury in the tube and in the pump. The outlet pipe of the pump is connected to the tube on the side of the conical spring base, and the outlet pipe – at the top of the spring cone. The pump is connected to a drive engine with an autonomous source of energy. The case of the device is fitted with mounting elements to connect it to the mobile object; in that case the converter of rotary motion is fitted with a pump, and the basic rotating element presents a tube in the form of a cone-shaped spring, which is coaxial to the axis of the device. The cone-shaped spring can be one-thread and screw. The pump is coaxial to the axis of the device.

When the device is turned on, the drive, connected to the pump and the basic rotary element, switches on. The tube in the form of a cone-shaped spring starts to rotate, dragging the mercury. At the same time, the pump returns the mercury along the axis of the device from the base of the cone-shaped spring to the top of it.

By this means, the mercury constantly travels along the tube in the form of a cone-shaped spring. Due to the fact, that in the initial period of rotation there is speed differential of the mercury and the tube itself, there appears propulsive burn, axially oriented.

Still, such kind of interaction between the liquid and the tube provides a short term propulsive burn (ranging from several seconds to a minute), which eliminates in the moment, when the speed of the

liquid equals the speed of the tube rotation. The experiments with this device have been described by one of the devisers, V. A. Menshikov in the article [10].

Thus, this device provides conversion of the liquid rotary motion into the forward motion of the structure, that is the impulse of the useful one-way tractive force, which operates only during a small period of time, that is why this device cannot be effectively applied in the structures that demand continuous running, e.g. in carriers.

The objective of the applied invention is to generate constant tractive force with efficient conversion of kinetic energy of the rotating mass into the forward motion of the system as a whole. As the effectiveness of such systems is in direct relation to the speed of the working mass rotation, then liquid, gaseous, granular or plasmous rotating mass will allow increasing specific properties of the device in comparison with the devices using solid gyrating masses.

Object of the Invention

The basis of the invention is the task to create a method that would provide constant normalized difference of speeds of the working mass and a device to impart motion to the working mass along the set trajectory and that would provide constant tractive force. The other object of the invention is a device, where the one-way conversion of the rotary motion of the working mass into the forward motion of the structure would be performed due to the interaction of the working mass with a rotor and due to the interaction of the working mass with the structure case, moreover it should be constant and highly efficient, so that it could provide the basis for the new generation carriers.

Summary of the Invention

The posed problem is solved by the fact, that in the method of rotation force exertion by means of the rotary motion conversion into the forward one, to set the working mass in rotary motion, in accordance with the invention there is permanent affection of the rotating working mass to alter the radius of its rotation. This happened due to the fact, that there is constant relative speed of motion between the working mass and the structure elements.

The other posed problem is solved by the fact, that in the device to exert driving force by the alteration of the working mass rotary motion into the forward motion of the whole structure, that is composed of a case, a coaxial device inside to impart motion to the working mass along a special trajectory, a drive and a source of energy. In accordance with the invention, the device to impart motion along a set trajectory to the working mass is executed in the form a conical rotor, on the tapered surface of which there is a helical spiral, and of a conical case, the walls of which are close to the rotor; the device is provided with an additional outer case to enclose the inner conical one, and there are through holes near the base and near the top of the conical case to join the inner space of the conical case to the inner space of the outer case; the inner conical case is rigidly attached inside the fixed outer case, and the conical rotor is installed in the outer case to enable its axial rotation.

Due to the fact, that a device to impart motion to the working mass along the helical spiral with reducing radius of rotation is executed properly, the rotating conical rotor moves the working mass along the set trajectory relative to the fixed conical case. It provides constant relative speed, which is a mandatory requirement of the impulse impartation to the case of the device; that is why the conversion of rotary motion of the working mass into forward motion of the whole system in one direction continues constantly.

Moreover, a force of reaction, targeted along the axis of rotation on the conical rotor from the moving working mass, as the reducing radius of the inertial mass rotation radius increases its linear speed, which exceeds the speed of the working elements of the rotor. **Thus, the conversion of rotary motion into forward motion of the whole device results from the interaction of the moving working mass with the conical rotor.** That is why the installation of the suggested power devices on a carrier should be performed in pairs with the opposite direction of the rotor rotation, but in the same direction of the driving force that will make it possible to compensate the moment of rotation imparted to the outer case of the device.

The optimal slope angle of the spiral, conditioned by its pitch, depends on the speed of the working

mass rotation in the involved section of the cone; that is why the varied pitch of the spiral may expediently be used to define the working elements location.

Multifilar helix makes it possible to increase the quantity of the working mass, moving along the defined trajectory in the clearance between the conical rotor and the conical case, which can thus increase the output.

Brief Description of Drawings

The invention is illustrated by drawings, where Fig. 1 shows a device constructed in accordance with the invention.

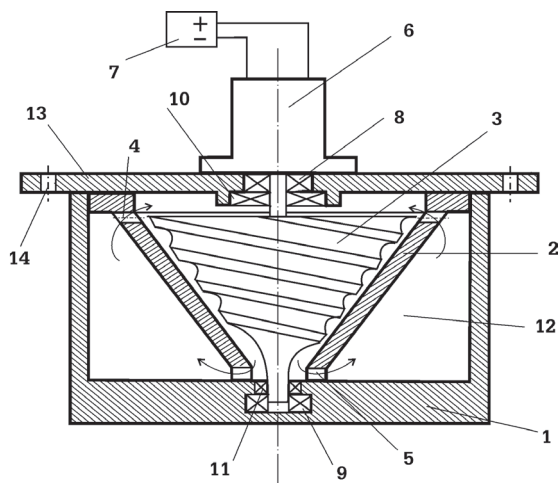

Fig.1

Fig. 2 shows another way of the invention construction, with a helical curve with opposite-directed spirals on the inner surface of the conical case to increase the effectiveness of the curvilinear motion of the working mass into the axial traction force.

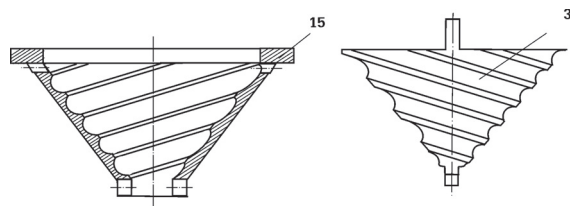

Fig.2

Fig. 3 is a variant of the rotor with non-linear alteration of the cone radius and altering pitch that increases from the base of the cone to its top.

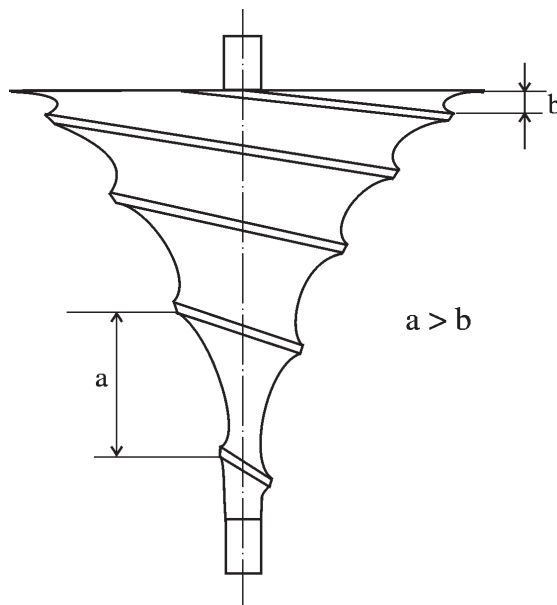

Fig.3

Detailed Description

As Fig. 1 shows, the device consists of an outer case 1 with an inner conical case 2 that has a conical rotor 3 inside with inlet and outlet holes 4 and 5 for the liquid circulation. Drive 6 provides the rotor 3 rotation, consuming energy from source 7. Bearings 8 and 9 are guarded against liquid with sealing glands 10 and 11. Liquid 12 fills the whole chamber of the outer case, including the space between the inner conical case and the rotor. The outer case lid 13 has mounting holes 14.

The device works in the following way. When drive 6 is turned on, rotor 3 is set in rotary motion. The helical spiral form of the rotor sets the liquid in motion. Centrifugal force presses it against the inner surface of the case, with probable spiral working elements.

In this case due to the relative differential speed, the working mass and the case start to interact and it changes the trajectory of the upper layer of the working mass and transfers the equivalent

impulse to the case of the device. If the rotor and the case are conical, the working mass is set in motion and forcedly shifted towards the top of the cone. Still consideration must be given to the fact, that the mass starts its rotation in the base of the cone with a certain linear speed, which is determined by the rotor radius in this section. Inertial properties of the working mass are manifested in the fact that due to the conservation of momentum with reduced radius of rotation the linear speed of its movement exceeds the linear speed on this radius of the rotor rotation. There appears differential speed of the working mass and the rotor, and the speed of the rotor surface is lower than the speed of the working mass.

Thus, the reason of the constant force, exerted on the rotor along the axis of its rotation, are inertial properties of the working mass, which forcedly travels along the spiral trajectory with reducing radius of rotation. In natural conditions the gas or liquid rotation leads to a vortex in a form of a non-linear expanding spiral, and together with the altered radius of the vortex particles rotation, the spiral pitch alters as well. The optimal form of the rotor is a form close to a natural vortex, Fig. 3. Such structure of the rotor demands a corresponding form of the conical case.

During the experiments we designed a device, the case and the basic detail of which were made of aluminum. The rotor diameter at the base is about 80 mm, and in the area of the liquid outlet – about 20 mm. To produce a vortex we used a standard electrical engine with a 12V accumulator. The power consumption was about 50W. The speed of rotation ranged from 30 to 300 rpm due to the

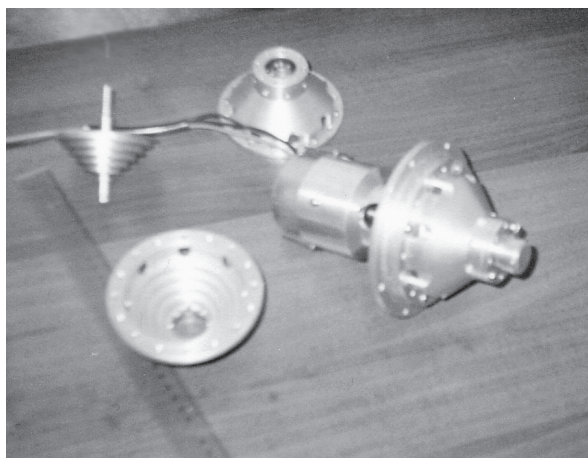

Fig.4
Details of the vortex drive

changed supply voltage. Water and other liquid substances, density of which exceeds that of water were used as working liquid. The produced force was measured with electronic scales to within 0.1 g. The received results let us draw a positive conclusion about the performance of this method and of its practical application.

References

1. The USA patent No 5280864 of January 25, 1994, James F. Woodward, Method for transiently altering the mass of objects to facilitate their transport or change their stationary apparent weights.
2. The USA patent No 4631971 of December 30, 1986, Bradson R. Thornson, Apparatus for developing a propulsion force.
3. The USA patent No 5427330 of June 17, 1995, Ezra Shimshi, Sphereroll.
4. The USA patent No 5782134 of July 21, 1998, Kames D. Booden, Electromagnetically activated thrust generator.
5. The USA patent No 5557988 of September 24, 1996, John C. Claxton, Centripetally impelled vehicle.
6. The USA patents Propulsion system No 5111087 of May 5, 1992, No 5334060 of August 2, 1994, No 5410198 of April 25, 1995, Kemal Butka
7. The USA patent No 3979961 of September 14, 1976, Nicholas Joseph Schnur, Method and apparatus for propelling an object by an unbalanced centrifugal force with continuous motion.
8. S. M. Polyakov, O.M. Polyakov, Introduction to the experimental gravitonics, pp. 58-59, Moscow, Prometey, 1991.
9. The RF certificates on utility models, No 34 10.12.2001, p. 396, A device to convert rotary motion into forward motion in one direction, V.A. Menshikov, A.F.kimov, A.A. Kachekan, V.A. Svetlichny.
10. V.A. Menshikov, Experimental research of gravitational propulsion systems construction, the "Polyet" magazine, No 10, 2001, pp. 38- 39, Moscow .



Fig.5
Weight changes testing

Permanent magnet / pulsed DC electromagnet motor-generator

Gary Magratten

daisy@saber.net

Date: Wed, 11 Aug 2004

Dear Mr. Alexander V. Frolov,

*Attached are some recent pictures of
PM/PEM2, MG Permanent magnet / pulsed
dc electromagnet motor-generator.*

*We get excellent results from the motor
and alternator separately. The bearings
were not designed for lateral loading. We
think that this can be easily corrected by
redesigning the unit to be balanced laterally
as well as axially.*

*There will be a full Engineering Report
soon.*

*Respectfully,
Mr. Gary Magratten*

*Editor: I have to note that idea of the device
described here is very similar to well known
Robert Adams' Motor. But in any case the
article is very useful for experimenters
building this kind of high efficient devices.
Alexander V. Frolov*

Permanent Magnet / Pulsed Electromagnet Motor – Generator

Build a 2" round by 2" long electromagnet. Start with a 3" by 3/16" carriage bolt. Place a 2" o.d. 3/8" i.d. steel washer on the bolt. Cut a plastic washer from a recycled plastic lid. Use the steel washer as a template. Place the plastic washer on the bolt. Cut a piece of mild steel 3/8" i.d.

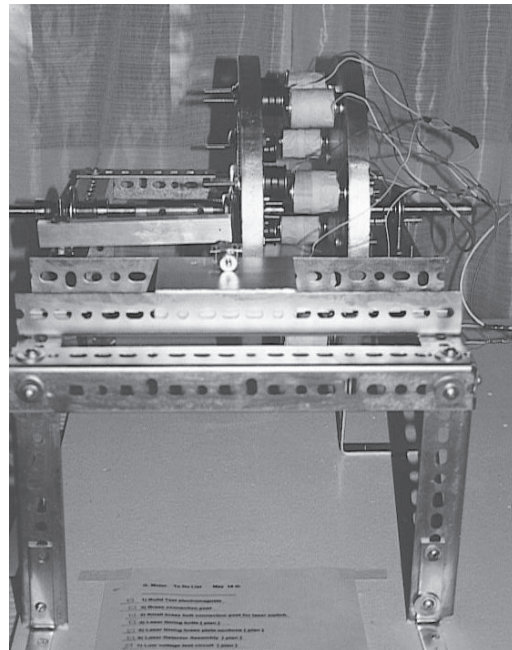

pipe 2" long. Place the pipe on the bolt. Place an other plastic washer on the bolt and then add an other 2" steel washer with 2" i.d.. Secure the assembly with a nut. Cost [\$2.00] Wrap the steel pipe with one layer of electrical tape. Wind # 20 P.E. magnet wire on the steel pipe-bolt assembly. Insulate each layer with electrical tape and bring the wire straight back to start another later. Try to get 1,000 turns of magnet wire on the bolt. You will need about 340 I. ft. of magnet wire that you can get from any motor repair shop. cost [\$6.00] Keep the magnet wire leads about 6" long. Connect two #16 stranded copper insulated wire leads on to the magnet wire leads. This is a simple electromagnet. Purchase a 1-1/8" o.d. by 3/8" i.d. 3/8" thick ceramic magnet from a hardware store. cost [\$1.00] Place the ceramic magnet on the electromagnets carriage bolt and washer. Notice the attractive magnetic force. Place one wire of the electromagnet securely on the positive post of a 12 volt automotive lead acid battery.

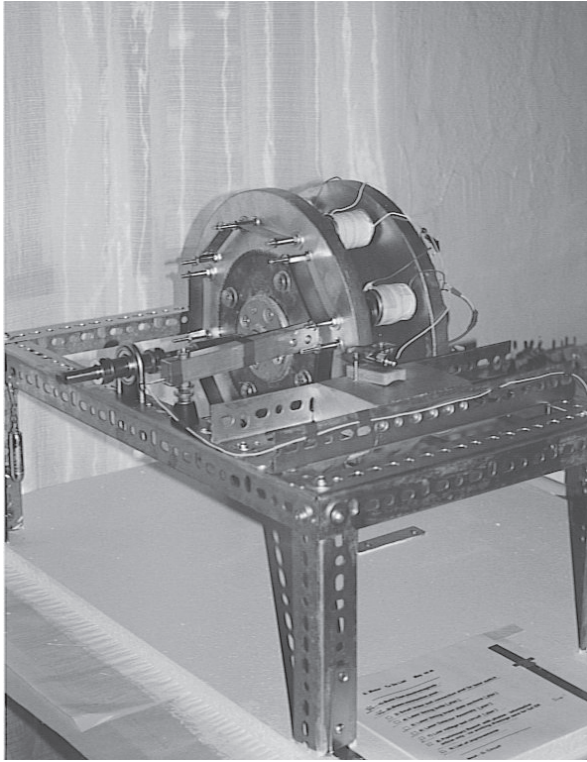

Now – briefly – scratch the negative terminal of the battery with other lead of the electromagnet. Notice what happens. If the electromagnet and permanent magnet are like poles, they will repel with a good deal of force. This is due to the transient current developed by the initial turning on of the switch. A capacitor will increase the transient effect. If the poles are opposite, the electromagnet attracts the permanent magnet.

This is a low voltage, safe demonstration of how briefly pulsing an electromagnet can perform useful work. This is the basic principle of a permanent magnet / pulsed electromagnet motor-generator. The rotor consist of permanent magnets. The stator consist of electromagnets. During the attractive phase of the two magnets coming into alignment, the magnetic flux of the permanent magnet attracts the soft steel core of the electromagnet. No power is consumed.

During the repulsive phase, after the magnets have passed center, a short duration pulse of high current is delivered to the electromagnet at the optimum time. The like pole of the permanent magnet provides half the magnetic flux for the repulsion phase. The only power

consumed to perform work is for a brief [milli-sec.] pulse, each time the magnets are slightly passed alignment. Most of the work [torque to the shaft] is done by the permanent magnets. A conventional electric motor consumes power constantly. Theory is fine and necessary, but theory must be confirmed by experimentation. I am an engineer and a firm believer in scientific method. If a theory is proposed, then an experiment that follows the design, build, test and report procedure confirms whether the theory works or does not. This experiment is safe to perform. Please do not try to discharge a high voltage capacitor or other high voltage apparatus through the electromagnet unless you a trained electrician or electrical engineer. Obviously the greater the voltage, the more the current. The strength of the electromagnet is dependent upon the number of turns and the amperage traveling through the coil.

Rare-earth permanent magnets are 4 times more powerful than ceramic magnets. If you use a stronger magnet please be careful – it is not for kids. Work safely and have fun!

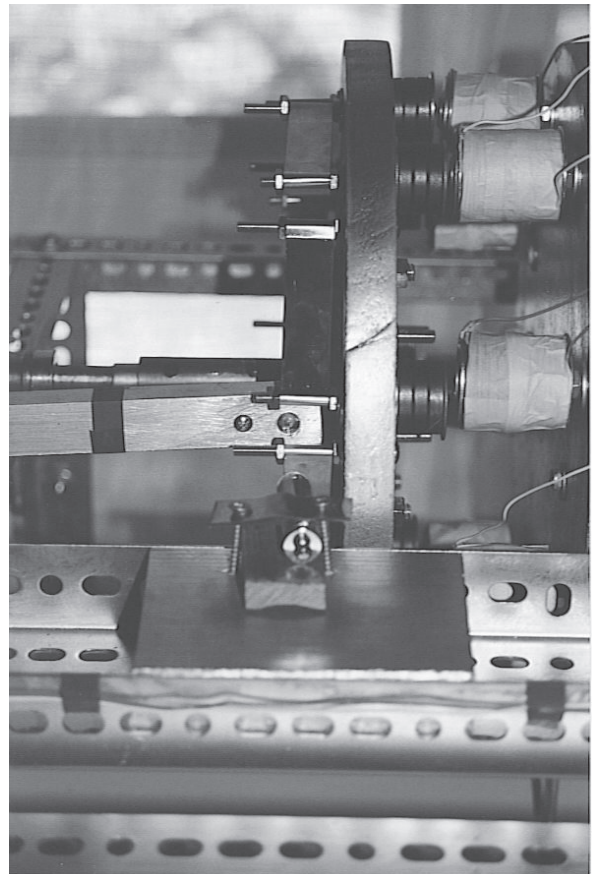

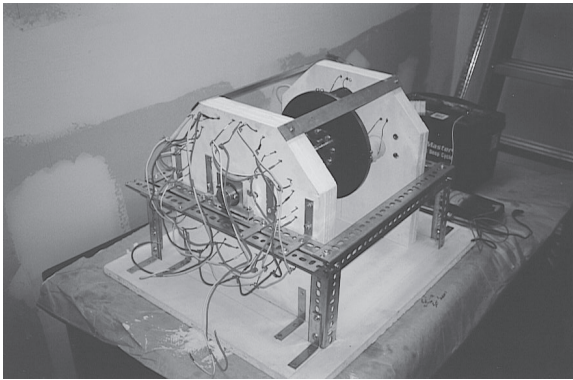

Transient Currents and Transient Voltages Power Pulse

In the design of a permanent magnet / pulsed dc electromagnet motor-generator, the creation of a high power pulse at the optimum time, when the permanent magnet and electromagnet are slightly past alignment, is the goal. The use of power is confined to a brief, few milliseconds thus conserving power and increasing efficiency. In order to create a high power pulse at the optimum time, it is helpful to analyze transient currents and transient voltages.

A transient current effect is associated with sudden changes in voltage when an emf is first applied. A transient current is developed when a switch is turned on. In this condition, the

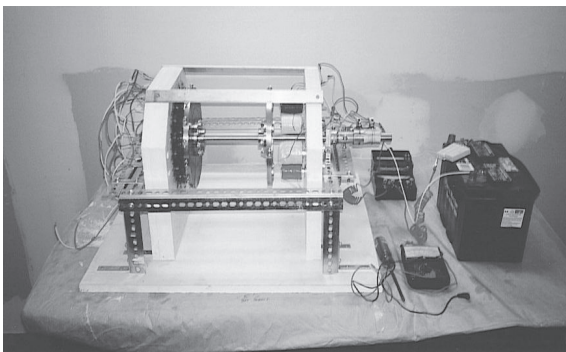

power is off in the circuit and then the switch is closed. At this point in time, power, being current and voltage being to flow in the circuit, but at different rates. When the switch is first closed there is an immediate surge in current which decreases exponentially over time to a steady state current. The voltage, on the other hand starts at zero and increases exponentially to a steady state condition.

The transient current effect is significant in two conditions, when a capacitor is employed in a basic RC circuit and when a high-voltage spark gap, exposed to open air creates an avalanche of free electrons.

Let us examine a series circuit with a capacitor and resistor. In a simple RC circuit the exponential change in current and voltage occur during a period of five time constants. As the switch is closed, one half of the current stored on the negative plate of the capacitor surges into the conducting circuit during the first time constant. The initial value of the current is determined by the voltage of the capacitor and the resistance in the circuit. The amount of transient current is directly proportional to the voltage and inversely proportional to the resistance. The less the resistance, the greater the initial current. This high current pulse or transient current can be of a much higher value than the normal allowable current rating for the wire size. This is because the duty cycle, time on / time off, allows the wire to cool in between pulses. This is important because the strength of the inductive pulse is determined by the amperage and the number of turns on the electromagnet.

Simple stated, the charge on the capacitor provides a powerful pulse of current to the electromagnet when the switch is first closed. This high current pulse forms a very strong magnetic flux in the turns of the electromagnet. The transient current provides an inductive kick to forcefully repel the permanent magnet and electromagnet. An other condition where a transient current is developed is by the means of avalanche due to the ionization of air molecules in a high-voltage spark gap exposed to open air. It is sufficient to say that with a spark gap exposed to open air of 4 mm at 5,000 vdc the process of avalanche produces some 5,000 free electrons that are absorbed by the high voltage anode into the circuit for every initial electron that leaves the cathode.

Editorial note: Experiments to increase current in electrical circuit by means of air ionization were demonstrated also in 1996, New Ideas in Natural Sciences conference, St.Petersburg, Russia. This method was patented by Russian scientist P.Yablotchkov, 1877. Efficiency was about 200%.

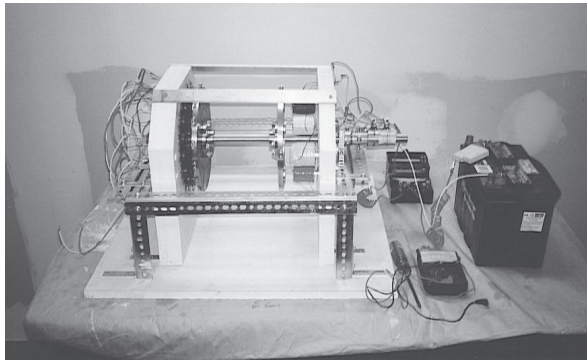

Permanent Magnet, Electromagnet Phase Diagram Description

Transition – The permanent magnet of the rotor is between electromagnets. The momentum of the rotor, [fly wheel], carries the permanent magnet to the electromagnet.

Attraction – The permanent magnet is close enough to the electromagnet. No power is supplied to the electromagnet. The torque is supplied by the magnetic flux of the permanent magnet.

Neutral – Brief alignment of the permanent magnet and electromagnet center.

Repulsion – When the permanent magnet center is slightly past the electromagnet center, a pulse of power fires through the electromagnet causing the poles of the permanent magnet and electromagnet to repel each other.

Back EMF – The permanent magnet is well past the electromagnet. The initial pulse of power creates a magnetic field. Upon the end of the power pulse, the electromagnetic field collapses creating a useful voltage which may be employed to recharge a secondary battery.

Transition – The cycle is then repeated with each alignment of the permanent magnets and electromagnets.

Power is consumed only during the repulsion phase. Here a short duration, high current, high voltage pulse at the optimum time provides torque to the rotor. An equal amount of torque is provided by the attraction phase where the magnetic flux of the permanent magnets do the work. This greatly increases the efficiency of the motor.

A detailed explanation of the avalanche process can be found in the work of L.Loeb and J.Meek's 'The Mechanism of The Electric Spark'. Transient voltage can be employed to create avalanche. A transient voltage is developed when a switch is turned off. In this condition, the power is on the circuit and the switch is opened. Automotive type ignition coils are an excellent example of transient voltage spike. The conventional Kettering spark ignition system uses a coil which performs the dual function of energy storage and voltage step transformer. It is typically about 100:1 turns ratio. DC power is applied to the primary producing a current of about 5 amps through the 8 mH coil, storing 100 mJoule of energy. When the current is interrupted by the points opening [switch is turned off], the voltage rises to 300 – 400 volts, $(L di/dt)$ which is stepped up to 30 – 40 kV (open circuit) in the secondary. This delivers the voltage spike necessary to ionize the air in the spark gap and cause avalanche. The dramatic increase in current developed in avalanche combined with the large voltage spike can produce a very powerful, short-duration pulse of power. This can be employed to produce high magnetic flux in the coil of the electromagnet for the repulsion of the permanent magnet and electromagnet at the optimum time for the optimum duration. In summary, there are two means by which an intense power pulse can be developed to provide high inductive kick that repels the electromagnet and permanent magnet of a permanent magnet, pulsed dc electromagnet motor-generator. The instantaneous discharge of a large capacitor and the combination of avalanche with the voltage spike of an ignition type transformer. It is my sincere hope that this information will clarify the technology necessary to create a power pulse for those involved in the R&D of permanent magnet / pulsed electromagnet motor-generator systems.

OVER UNITY PROPULSION

OF A ZERO POTENTIAL CASING ASYMMETRIC CAPACITOR SYSTEM

Prof. Nassikas A.A.

Technological Education Institute of Larissa
10, Ethnikis Antistaseos Str., 41335 Larissa
E-mail: a.a.nass@teilar.gr

The author wishes to thank Prof. A. Maglaras for his classical methodology calculations according to the "Quick Field" programme and according to author's desing.

Purpose of this paper is to describe a system for developing a thrust by means of asymmetric capacitors which are created when a set of metallic elements are placed in a non-symmetric way inside a solid strong insulation dielectric means that in turn is placed inside metallic casing of zero potential. This thrust, when the system works without having corona effects, leads to over unity energy production; this can be explained within a physics theory, which is based on the claim for minimum contradictions.

Introduction

It is already known from existing patents that the asymmetric capacitors develop a non-regular (abnormal) thrust as a result of high voltage imposed between the positive and negative plates. Indicatively the patents [1-7] are mentioned. It is also mentioned A. Frolov's asymmetric capacitor system which is described in [8,9]; in these papers a reference has been made to the experimental confirmation for the thrust development possibility in asymmetric capacitors having horizontal and vertical metallic plates. Recently the "lifter" device has been reported whose thrust is of the order of 2.5N [9,10]. In the above patents and papers there is not used an electrostatic arrangement with a solid strong insulating dielectric means, surrounded by a metallic casing of zero potential. A basic advantage of the system proposed is the fact that the mechanism described herein is externally electrically neutral.

This fact constitutes an advantage concerning on the one hand the use and on the other hand the thrust force multiplication capability by

placing similar devices in contact. Another advantage is that the strong solid insulator dielectric contributes to the performance of the system proposed due to its insulating capability, independently of its specific inductive capacity (dielectric constant). The use of a strong insulation material as dielectric means in combination with the geometry of the interposed metallic elements, as well as the connection way of the insulation dielectric means with the metallic elements and with the metallic casing provide the capability of a light construction and a very high thrust; e.g. system whose main weight is the one that would have a plastic plate of 5 mm thickness, can provide a thrust of 40 kp/m². Ten parallel such systems of total thickness 50 mm can provide a thrust force of 400 kp/m². When the system is working without having corona effects this means that the energy offered to the system is practically zero. Thus, when, according to calculations, the system is moving we have energy production of an over-unity effect. This effect can not be explained within a classical physics; it could be explained with a physics theory, which is based on the claim for minimum contradictions [11,12]. According to this theory space-time is matter itself and it has both massgravitational (g) and charge-electromagnetic (em) components. The charge space-time is regarded as an imaginary gravitational space-time which coexists with the real one the two of them being interconnected. This point of view permits us to explain the thrust and the energy, of the system mentioned, since there is something material i.e. the gravitational space-time, which offers the momentum and the energy required. In a moving electrostatic system, where there

is not charge motion with respect to the existing electric field, the energy produced could be due to the gravitational space time energy absorbed through a gravitational matter space time field created due to the existing electric field; the thrust could be due to gravitational space time absorbed momentum change; such a moving system is the system under study.

2. Proposed Asymmetric Capacitors System

2.1 General

Inside a dielectric means 1 (Fig. 1) are placed metallic conductors 3 which are electrically charged in relation to the metallic casing 2, which is electrically neutral.

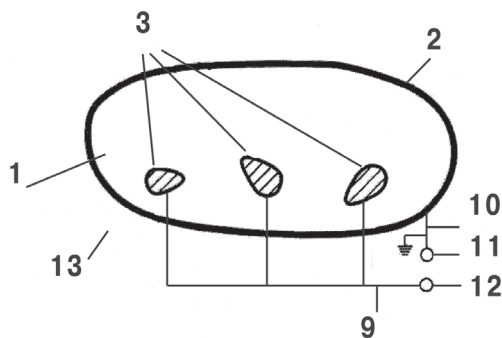

Fig.1

Zero potential casing asymmetric capacitor system . General arrangement

This is achieved by means of high voltage imposed between the conductors 3 and the metallic casing 2. We assume that the electrostatic field equation is everywhere in force, which concerning isotropic materials with constant specific inductive capacity (dielectric constant) is as follows:

$$\text{div} \vec{E} = -\nabla^2 \phi = \rho / \epsilon \quad (1)$$

where E_r is the field intensity, ϕ – the potential, ρ – the density of spatial charge.

The force F according to equation (1) for an area enclosed by a surface S is [13]:

$$\vec{F} = \frac{1}{2} \oint_S [\vec{E}(\vec{n}\vec{D}) + \vec{D}(\vec{n}\vec{E}) - \vec{n}(\vec{D}\vec{E})] ds \quad (2)$$

where D is the electric displacement and \vec{n} the orthogonal unitary vector on the surface S directed outside the area enclosed by the surface S . Consequently the resultant force F_{tot} on the whole system, according to equation (2) will be:

$$\vec{F}_{tot} = \frac{1}{2} \oint_{out2} (D\vec{E}) ds = \frac{1}{2} \oint_{out2} (dq / ds) \vec{E} ds = 0 \quad (3)$$

where ds is an elementary surface unit and dq the surface charge corresponding to the surface dS .

The force F_{tot} is equal to zero because the field intensity E on the outer surface of the casing 2 is equal to zero. In reality a charge dq on a metallic surface creates by induction a charge q_d on the dielectric 1 surface so that:

$$dq - dq' = \frac{dq}{\epsilon_r} \quad (4)$$

where ϵ_r is the relative dielectric constant of the dielectric means 1 [14,15].

Due to the equation (4), the total resulting force F , exerted on the charges dq and $(-dq')$, because of the existing electric field of intensity E corresponding to a surface element on the surfaces 2_{in} or 3_{out} , will be:

$$d\vec{F} = \frac{1}{\epsilon_r} \vec{E} dq = \frac{1}{\epsilon_r} \vec{E} \frac{dq}{ds} ds \quad (5)$$

A coefficient $1/2$ is needed because of dq and (dq') , distribution [16]; Eq.(5) shows that at the system surfaces always an acting force exists. Because of Eq.(5) we have:

$$\vec{F}_{tot} = \frac{1}{2\epsilon_r} \oint_{2in,3out} (dq / ds) \vec{E} ds = \frac{\vec{F}_M}{\epsilon_r} \quad (6)$$

wherein F_M is the total resultant force exerted on the conductors 2, 3, being derived if we assume that equation (2) is in force. Then F_{tot} according to equation (3) should be equal to zero. When however the total resultant force F_M exerted on the metallic elements 2,3 is not equal to zero, then, according to equation (6), F_{tot} will not be equal to zero as

well. The aspect that, according to equation (3), F_{tot} is zero, is compatible with the fact that the work of F_{tot} must be equal to zero when the externally offered energy is equal to zero (constant voltage and absence of leakages). However, the equation (3) does not take into consideration the exact forces which are exerted on the sum of the charges dq and (dq') , Eq.(6) takes into account the forces and the particularities of the boundary conditions between the surfaces 2_{in} , 3_{out} and the dielectric means 1. At the same time Eq.(6) calculates F_{tot} on the basis of the simulation being derived if we assume that the equations (1,2) are in force, i.e. on the basis of the classic solution of the field of fig.1 (boundary conditions of constant voltage on the elements 3, zero voltage on the casing 2 and dielectric constant of element 1).

Thus the question is raised of whether the classical approach, where F_{tot} is zero, or Eq.(6) where F_{tot} can be non zero, is valid. From Eq.(1) derives that we have charges in the whole extend of the dielectric 1 if the potential second derivative is not zero; this usually is valid in asymmetrical capacitors and it can be verified by the aid of finite elements calculation in various systems and more specifically in the system proposed as it will be later described. According to the classical point of view [Eq.(2)] the charges in dielectric 1 are virtual and they are used only for the purposes of the electrostatic field solution. Obviously this point of view is arbitrary; therefore Eq.(6) is more consistent since it takes into account the existing real charges.

2.2 Specific Arrangement [16]

The specific arrangement proposed is depicted in Fig.2. The elements 3 (3.1 and 3.2) are formed by metal deposition (e.g. by means of the “e-beam evaporation technique”) on the strong insulation solid dielectrics 1a and 1b, excluding the surfaces 8, wherein the elements 1a and 1b are formed by casting plastic material, e.g. polyethylene. The surfaces 8 may be covered by a mask and using a technique like lithography, in the case of metal deposition they can be cleaned and remain uncovered. On the contrary, all the rest surfaces

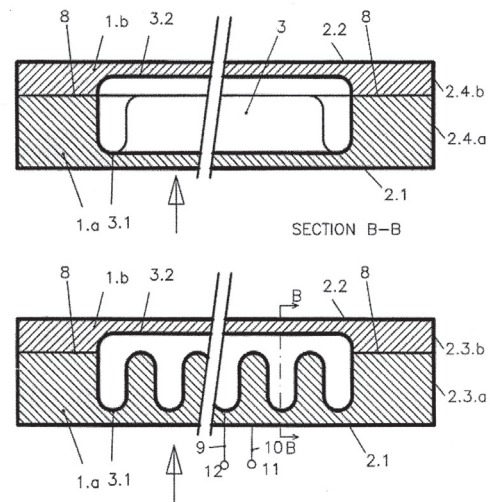

Fig.2

Zero potential casing asymmetric capacitor system
Specific arrangement

of the sections 1.a and 1.b are covered by a metallic substance e.g. chrome or nickel. The sections 1.a and 1.b are joined along the surfaces 8 by an insulation adhesive forming plates of dimensions e.g. 5 mm x 300 mm x 300 mm. In the case of metal deposition on dielectric, the developed cohesion is high enough to exclude the creation of gaps, which could be the cause of voltage breakdown; voltage breakdown is also avoided due to the curvature of the lower parts of element 3. The metal elements 3 and 2 are connected to the high voltage ends 11 and 12 through the conductors 9 and 10, where the conductor 9 is electrically isolated in such a way that electrical leakage to be avoided. In this way a thrust is created mainly due to the electric interaction of the element 3.1, the element 2.1 and the interposed dielectric 1a.

We use the method of finite elements for the arrangement of figure 2 with the following boundary conditions[16]. The voltage on the elements 3 is 20.000 V The voltage of the casing 2 is equal to zero. The relative dielectric constant of the dielectric means 1 is $\epsilon_r=1$, The teeth height of the elements 3 is 2 mm The minimum distance between the elements 3 and 2.1 is 1 mm The minimum distance between the

elements 3 and 2.2 is 1.5 mm The distance between two consecutive corresponding points of the teeth of elements 3 is 2 mm The curvature radius of the lower parts of the elements 3 is 0.5 mm.

On this basis we find a resultant upward thrust $F_{tot} = 4.17 \text{ g/cm}^2$. The reduction surface of F_{tot} is the projection surface of the elements 3 on the inner surface of the element 2.1. This force is calculated-simulated according to the finite elements method, on the basis of Eqs.(1,6). Using the same method for various dielectric means 1 we notice that the force F_M exerted on the metallic elements 2 and 3 increase with the dielectric constant, not happening the same concerning the thrust F_{tot} because according to the equation (6) this force is inversely proportional to the dielectric constant. Thus, it is:

$$\begin{aligned} \epsilon_r = 1, & \quad \bar{F}_M = 4.17 \text{ gr}^* / \text{cm}^2, \quad \bar{F}_{tot} = 4.17 \text{ gr}^* / \text{cm}^2 = 41.7 \text{ Kp} / \text{m}^2 \\ \epsilon_r = 2,3, & \quad \bar{F}_M = 9.6 \text{ gr}^* / \text{cm}^2, \quad \bar{F}_{tot} = 4.17 \text{ gr}^* / \text{cm}^2 = 41.7 \text{ Kp} / \text{m}^2 \\ \epsilon_r = 5, & \quad \bar{F}_M = 20.85 \text{ gr}^* / \text{cm}^2, \quad \bar{F}_{tot} = 4.17 \text{ gr}^* / \text{cm}^2 = 41.7 \text{ Kp} / \text{m}^2 \\ \epsilon_r = 100, & \quad \bar{F}_M = 417 \text{ gr}^* / \text{cm}^2, \quad \bar{F}_{tot} = 4.17 \text{ gr}^* / \text{cm}^2 = 41.7 \text{ Kp} / \text{m}^2 \end{aligned}$$

(5)

In the case in which $\epsilon_r=2,3$ the dielectric means 1 may be polyethylene (PE). The maximum developed intensity is 230 kV/cm and lies under the limit at which the Corona phenomena for the PE start. In this context we observe that in order to have a high force F_{tot} it is of substantial meaning the dielectric means 1 to be a strong insulator, independently of its dielectric constant. Indeed, it is then possible for the same minimum distance between the elements 3 and 2.1 to appear higher allowable imposed voltage and consequently capability for higher thrust.

More specifically we can have the following data:

- Mechanism as the one depicted in Fig. 2
- Material of 1a and 1b, polyethylene
- Metal deposition, chrome or nickel
- Fig. 2 plate dimensions, 5mm X 300mm X 330mm
- Thickness (1a +1b), 4.5mm
- Weight 4kp/m²

- Propulsion 40kp/m²
- Propulsion of a system consisting of 10 systems in touch as described above 400kp/m²
- Rest elements as described in finite elements method calculation

A simple and obviously working asymmetrical capacitor is the Frolov's one[8,9]. In Figure 3 a Frolov capacitor is depicted. According to this figure the forces exerted on the central metallic plate are eliminated, while remaining the forces achieving an upward thrust. This capacitor is an open-type one i.e. it exists within an electrical field, which is extended to the infinity.

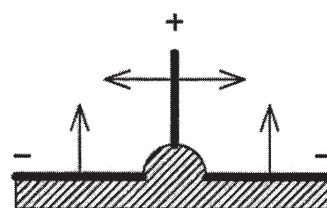

Fig. 3. Frolov's asymmetrical capacitor

Editorial Notes: This scheme, which allows to get non-zero resulting force, was published in 1994, New Energy News, USA. However, I did not considered application of this idea as open air capacitor only. So, I see no novelty in the Nassiaks idea, which is additional proposal to use the same effect in closed case. Some later I developed more effective design of the asymmetrical caps. Alexander V. Frolov

The proposed asymmetrical capacitor system is investigated both for theoretical and for practical reasons. This system is restricted by an electrically neutral casing, which implies that the electrical field created is also restricted within this casing. Thus, if the system works, it does mean that it is not due to an electrostatic phenomenon; the system is rather gravi-electrical as it will be later explained. The feature of metal deposition on wave formed strong insulation solid dielectric as indicated in Fig.2 provide, for reasons mentioned above, a high thrust and a safe operation; this implies the existence of great measurable magnitudes which can assure an over-unity operation.

Because of the fact that the elements 2.1 and 2.2 of Fig.2 are metallic and electrically neutral, there is the possibility of multiplication of the resultant thrust force by means of two or more systems proposed by consecutively placing the next one on the former one, as depicted in fig.4 where the purpose is the energy production.

More specifically we can have the following data:

Mechanism as the one depicted in Fig. 4

- Mechanisms – plates 13 as in Fig. 2
- Material of 1a and 1b, polyethylene
- Metal deposition, chrome or nickel
- Radius of disc 16, 100mm
- Fig. 2 plate dimensions, 5mm X 50mm X 300mm
- Rest elements as described in finite elements method calculation
- Number of plates 13 within the ring defined by the elements 14 and 15, $n = 125$
- Torque . = 900kpcm
- Power . for 4000rpm . = 50HP

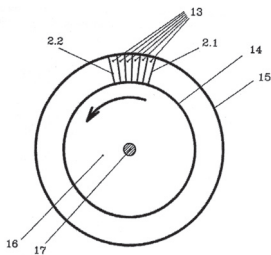

Fig.4. Zero potential casing asymmetric capacitor system
Energy production arrangement

Editorial notes: T.T.Brown's patent of 1927 also describes application of so called "gravitators" - it is asymmetrical capacitors to create propulsion force when they are placed on some rotor. It will create rotational momentum and this principle can be used to generate electrical power from the generator. T.T.Brown wrote that efficiency of this generator can be 1,000,000 to 1, considering that the leakage current can be very small. Alexander V. Frolov.

3.Explanation Basis

When the system is working without having corona effects this means that the energy

offered to the system is practically zero. Thus, when, according to calculations, the system is moving we have energy production of an over-unity effect. This effect can not be explained within classical physics; it would rather be explained with a physics theory which is based on the claim for minimum contradictions [11,12].

Our basic communication system, which consists of the Aristotle logic, the Leibniz sufficient reason principle and the claim that there is anterior-posterior in our communication, is contradictory [11,12]. Thus, any consequences of this system can derive with the aid of a claim for minimum contradictions. On this basis a physics theory is least contradictory when it is described in anteriorposterior and in extension in space-time terms. This leads to a matter space-time aether in which things exist and from which things are made. Lorentz's transformations derive on condition that a perfect (non-contradictory) physics theory can be stated; in this case, space-time is regarded as continuum. However, a physics theory is contradictory since it is expressed through the basic communication system. This leads, on the basis of the claim for minimum contradictions, to a stochastic matter spacetime.

The Claim for Minimum Contradictions, though being completely general, can lead by itself to the statement of minimum contradictions physics theory [11,12]. As it was mentioned according to this theory space-time is stochastic and it can be regarded as matter -aether. However, matter can be either mass or charge. Thus, there exist both mass-gravitational (g) and charge-electromagnetic (em) spacetime. The (em) spacetime behaves as a (g) spacetime , since both are spacetime and obey the same principles but it is not. Thus, any time interval in the (em) spacetime is incomprehensible with respect to a coexisting (g) spacetime and it can be regarded as an imaginary number which is incomprehensible too. A basic conclusion of this theory is that "The energy of any oscillating infinitesimal spacetime is equivalent to its internal time";

where as internal time is defined a time of a phenomenon of comparison. According to this conclusion the energy of an infinitesimal (em) spacetime can be regarded as imaginary since it is equivalent to an (em) time interval. Therefore, in general, the electromagnetic energy can be regarded as imaginary. A gravitational spacetime energy $g E$ can be converted into an electromagnetic spacetime energy $em E$ by means of photons and vice versa this being compatible with the first thermodynamic axiom. In extension (em) mass and momentum are imaginary as well. Because of the fact that the interactions between the (g) and the (em) space-time take place through photons we may assume that the momentum conservation principle is valid [17].

On this basis a space-time-matter field in general, locally behaves as a particle-space-time field; if we put $1 = \hbar c$ the following equations are valid [11,12,17,18].

(equations 7-11)

$$\partial_{xi} \frac{\square \Psi_g(\vec{r}, t)}{\Psi_g(\vec{r}, t)} = 0, \quad \partial_{xi} \frac{\square \Psi_{em}(\vec{r}, t)}{\Psi_{em}(\vec{r}, t)} = 0 \quad (i=1,2,3,4)$$

$$\partial_t \left(\frac{\partial_t \Psi_g(\vec{r}, t)}{\Psi_g(\vec{r}, t)} + i\alpha \frac{\partial_t \Psi_{em}(\vec{r}, t)}{\Psi_{em}(\vec{r}, t)} \right) = 0$$

$$\partial_i \left(\frac{\nabla \Psi_g(\vec{r}, t)}{\Psi_g(\vec{r}, t)} + i\alpha \frac{\nabla \Psi_{em}(\vec{r}, t)}{\Psi_{em}(\vec{r}, t)} \right) = 0$$

$$\vec{g}(\vec{r}, t) = \frac{c^2}{P(\vec{r}, t)} \nabla P(\vec{r}, t)$$

$$\vec{g}_{em}(\vec{r}, t) = \frac{i\alpha c^2}{P_{em}(\vec{r}, t)} \nabla P_{em}(\vec{r}, t)$$

where α is the fine structure constant, Ψ_g и Ψ_{em} are the gravitational and the electromagnetic spacetime wave functions, which are identical with equivalent particle functions Ψ , and $a(r, t)$ is a point of a hypothetical measuring field(HMF)[11,12,18]. Eqs.(7) describe Schroedinger relativistic equations; Eq.(8) describes the energy conservation principle; Eq.(9) describes the momentum conservation principle. Eqs.(10,11) describe the gravitational acceleration of the (g) and the (em) space-time; the probability density $P_g(r, t)$ is function of Ψ_g , Ψ_g^* , and their time partial derivatives. Geometry of (g) and (em) space-time can be defined by means of Ψ_g , Ψ_g^* , Ψ_{em} , Ψ_{em}^* and their

time partial derivatives[18].

Eqs(7-9) describe any kind of energy and momentum interactions between the (g) and the (em) space in the whole extend of a system including its surrounding space. We don't know if this equation system can be solved since it rather refers to a fractal space[11,12].

However we can get useful information for gravi-electrical problems.

In a circle motion of a particle e.g. electron an outside momentum is always required so that its momentum is always continuously changing; this could take place through gravitational energy absorption which would imply a momentum interaction; since electron's energy remains constant the energy absorbed should be radiated. This is compatible with Kozyrev radiation[19]. It is also compatible with electron's radiation as it has been described by C. Whitney[20].

Eqs(10,11) show that the gravitational acceleration of the (g) space-time is interconnected with the gravitational acceleration of the (em) space-time since they are functions of Ψ_g , Ψ_g^* , Ψ_{em} , Ψ_{em}^* and their time partial derivatives which, because of Eqs(7-9), are interconnected. Thus we can state that an electrical field creates a gravitational one and vice versa.

Photon emission because of energy level swift of an electron in the hydrogen atom could be due to gravitational energy absorption and not due to potential difference in proton's field; thus, the energy produced in various chemical interactions could originate from something material (matter space-time absorption) and not from a pure mathematical notion as the notion of potential does[21].

On this basis we can explain the thrust and the energy, of the system proposed, since there is something material i.e. the gravitational space-time which offers the momentum and the energy required. In a moving charge within an electrical field, the energy produced is due to the gravitational space time energy absorbed; the force exerted is due to gravitational space time absorbed momentum

change. In a moving charge within an electrical field, the energy produced is due to gravitational space time energy absorbed; the force exerted is due to gravitational space time absorbed momentum change. In a moving electrostatic system, where there is not charge motion with respect to the existing field, the energy produced could be due to the gravitational space time energy absorbed; the thrust could be due to gravitational space time absorbed momentum change; radiation might take place for energy balance; a gravitational field can be created because of the existing electric field; thus it can provide the energy and the momentum required.

REFERENCES

1. T.T.Brown, A method of and an apparatus or machine for producing force or motion. GB Patent N°300311, 1928.
2. T.T.Brown, Elektrokinetic Apparatus. US Patent N°2949550, 1960.
3. A.H.Bahnon JR, Electrical thrust producing device. US Patent N°2958790, 1960.
4. T.T.Brown, Elektrokinetic Transducer. US Patent N°3018394, 1962.
5. T.T.Brown, Elektrokinetic Apparatus. US Patent N°3187206, 1965.
6. A.H.Bahnon JR, Electrical thrust producing device. US Patent N°3227901, 1966.
7. NASA (US)- Campbell J. (US), Apparatus for generating thrust using a two dimensional, asymmetrical capacitor module. US2002012221, 2002.
8. A.V. Frolov "Frolov's Asymmetrical Capacitors". New Energy Technologies, Faraday Laboratories Ltd. St Petersburg Russia, Issue #5 (8), 2002.
9. A.V. Frolov, The Application of Potential Energy for Creation of Power, New Energy News, USA, 1994.
10. <http://jnaudin.free.fr/lifters/>
11. A.A.Nassikas, "The Relativity Theory and the Quantum Mechanics under the Claim for Minimum Contradictions", Hadronic Journal, Hadronic Press, Inc, Vol. 5, No. 6, pp. 667-696 (2002).
12. A.A.Nassikas, "Minimum Contradictions Physics as a New Paradigm". NPA Conference, CT USA. Proceedings in Press, Journal of New Energy, 2003.
13. Quick Field, User's Guide. Tera Analysis Ltd, 2002.
14. J. D. Kraus, Electromagnetics. McGraw Hill, 1984.
15. Halliday, Resnich, Physics. John Wiley & Sons, Inc, 1976.
16. A.A.Nassikas, Developing a thrust force by means of an electrostatic device equipped with a strong insulation dielectric and a casing of zero potential. Patent Application 20040100246/11-06-2004, Industrial Property Organization, OBI Greece, 2004.
17. A.A.Nassikas, "On Minimum Contradictions Physics". AAAS-NPA Conference. Denver Colorado USA, 2004.
18. A.A.Nassikas, The Hypothesis of the Quantum Space Time - Aether. Galilean Electrodynamics, Special Issues 2, 2000.
19. A.N. Dadaev, Astrophysics and Casual Mechanics. GED Vol. 11, Special Issues, 2000.
20. C.K.Whitney. Do Atoms Really Have "States"? PIRT-VIII 2002. London.
21. A.A.Nassikas, "The Cold Fusion As a Space Time Energy Pumping Process". Proceedings of the 8th International Conference on Cold Fusion. Nuovo Cimento, 2000.

On this basis we can explain the thrust and the energy, of the system proposed, since there is something material i.e. the gravitational space-time which offers the momentum and the energy required. In a moving charge within an electrical field, the energy produced is due to the gravitational space time energy absorbed...

The nature of electric power interactions

Alexander V. Frolov

Faraday Lab Ltd

<http://www.faraday.ru> 7-812-3803844

The modern experiments on the use of asymmetrical electric accumulators in a role motors shows the perceptiveness of the given approach, but calls for corresponding theory development. In 1998, I offered a few sentences on nature of electric power interactions [1]. Taking the vector sum of tension of an electric field of two interacting bodies, Fig.1, we can make a conclusion that the reason of action of the attractive or driving away forces is the gradient electric field, created as a result of a superposition of usual fields of every body.

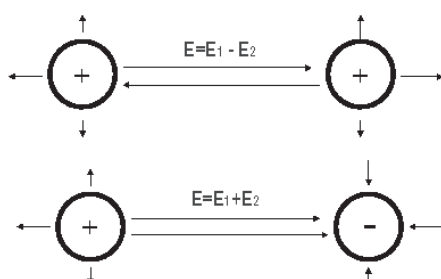

Fig.1

The summary intensity of the electric field between the bodies is more or less than intensity on the other sides. It is an obvious fact, but it was paid a little attention. It is important to take into account that the interaction is not happening between the bodies, but between each body and its surrounding space, in which a gradential electric field is created. Coming from here, assuming that the electric forces are one of the etherodynamics phenomenon, we come to a conclusion that this type drive must work as analogy to aerodynamical systems, but not by a way of creation of a reactive stream or wing air pressure gradient, but by means of creating of a ether pressure gradient. Different ether pressure in different parts of a device gives a non-zero resulting electric force, which have mechanical natural force.

Let's look at the given assumption more detailed. There are models of the physical vacuum, where the structure of vacuum is described as the paired virtual particles. The electric field may be explained, as a structured vacuum, in which, comparing to the usual vacuum, some polarization of the virtual particles occurs. When the polarization is strong, a pair of particles is born from vacuum (this is an experimental fact). In any case, even a weak electrical field changes the static balance of virtual particles as the result their polarization. Due to this polarization it becomes possible to transfer the impulse from a virtual particle to a real particle. For an observer this effect is displays as an electrical force interaction, i.e. attraction or repulsion of charged particles. From here is the conclusion: the basis of electric force interactions lays is mechanical phenomenon of an impulse transfer during collision of virtual and real particles. This phenomenon is ether-dynamics effect.

In article [1] an assumption was made, which can be practically proved if design and exploitation of powerful drive of this kind will be organized: It was assumed that the losing of some part of kinetic momentum from the virtual particles will change the space-time properties, that is curvature change, or other words, to a slowing or accelerating of any processes (speed of time) in space.

From here appears an understanding of physical principles of the electric drive work, known from T.T. Brown's times, that is from 1927. The special shape of the plates or a special properties of the dielectric, which is placed between the plates, let us get a non-zero resulting force, which is acting, on a system of electrically charged bodies in a result of the ether pressure gradient creating. It is important to note that in work [1] theoretically assumed a possibility of creating of a propulsion force in a single charged body.

For that it is necessary to create a gradient of electric field surrounding the given charged body. Technically it is achieved due to the special kind of dielectric with which the charged surface is covered. In the work [1] an example of calculation for the force, which is created by a charged surface of 100 square meters surface. For 10 kV potential the force is about 80 tons.

In some publications notions of “the asymmetric capacitors” or “Frolov’s capacitor” were mentioned. In 1994 in USA it was published by me some thoughts on application of electric fields in a specific configuration to produce some useful work without any wastes of power from the primary source of power [2]. On Fig. 2 there is a picture from that article, illustrating one of the cases of creating of a non-zero summary force of an electrical interaction. It is not even an capacitor, but a system of a few charged bodies.

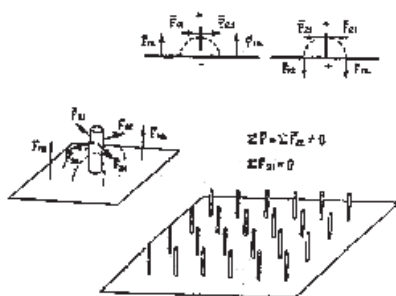

Fig.2

Later some other schemes were created, for example, the T-shaped dielectric let to create a co-directed forces for two opposite polarity charged bodies. (See Fig.3)

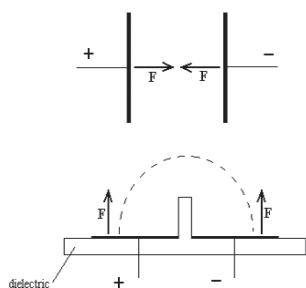

Fig.3

The same idea with a cylindrical dielectric have got the name “Frolov’s hat”, (Fig. 4)



Fig.4

Let us mark shortly that in some systems using crossed magnetic and electric fields also a propulsion force can be created, that is theoretically based as the pondemotoric effect (the vector of Umov-Pointing). This is one more ether pressure gradient effect. However in such sort systems it is necessary to create some rotation of fields and they also have some other disadvantages. That is why pure electrical drive appear to be more interesting for the designers of the new aerospace propulsion systems.

The most perspective direction of researches in the given area is the search for the technological decisions on the electric field gradient creation by means of dielectric specific properties but not by means of a special shape or the plates disposition. A single charged body, covered with such dielectric (the frame of the device can be a body like that) will be the drive of the new generation vehicles. At the same time the energy losses on the leakage currents, which are in reality will have a place, can be minimized. This will allow to build a transport of any cargo load capability and it will not demand of onboard powerful sources of energy. Thus, the cost of the cargo delivery to the space orbit can be decreased dramatically and the space exploration will become real commercial projects.

References

1. Frolov A.V., The active motion. The congress's “The Fundamental Problems of Natural Sciences” works, volume 1, pages 195-201, RAN publishing, Saint-Petersburg, 1999
- 2 Alexander Frolov, The application of potential energy for creation of power, New Energy News, volume 2, N 1, May 1994, USA.

New Product

Vortex heat-generator

Vortex heat-generator (VHG) is designed for heating and hot water supply for houses, buildings, industrial facilities, storage rooms and agricultural buildings located far from traditional heating sources.



Fig.1. The VHG-11, VHG-22 generators

These generators are designed and manufactured under the guidance of Academician Yu. S. Potapov, who is owner of the patent #2045715 registered in the Russian Federation (priority from 26.04.1993).

The VHG-generators extract heat from water and nonfreezable fluids by means of complex processes of intensive vortex motion which is created in a peculiar design. The heat energy released is by a factor of 116% - 120% more than power consumption of the motor of the pump making the fluid circulate (depending on the operating mode of the pump).

VHGs are supplied from 3-phase mains. The heat produced is used for heating water directly in heating systems by connecting generators to calorifers or heat exchangers.



Fig.2. The VHG-37, VHG-55 generators

The generators are free-running, environmentally friendly and highly economical plants. The temperature limit for their automatics operation is +95C.

The generators are reliable and high-performance in comparison with heating facilities of other types.

Compactness, maximum reduction of the distance from a heat source to a consumer, absolute ecological safety, programmed automatic control, no expenditures on construction and repairing of heating mains –

all this makes the generator one of the outstanding technical achievements of the present age. The maximum efficiency of the generators is achieved when their heat and hydrodynamic characteristics are matched with features of heating and hot water supply systems of buildings where the generators are installed. The efficiency factor of these generators is by 23% higher than that of electrode heaters and by 42% higher than that of thermoelectrical heaters.



Fig.3. Control panel of the generators

The heat-generators are provided with all accessories required to connect them to objects; they have an automatic control system. The generators can be easily connected both to a heating system under construction and to an existing one. Their design and sizes make it possible to install them just in any area.

Maintenance is to retain the quantity of the liquid required inside the system and to eliminate leakages from connection elements of the heating system.

Low operating pressure of the liquid inside the system makes the generators safe and durable. They don't use substances polluting the environment (like coal, gas, diesel oil). So, there is no emission of combustion materials and air consumption.

It is not necessary to get any special state certification to put the VHG in operation.

	BTY-11	BTY-22	BTY-37	BTY-55
Installed capacity (kW)	11	22	37	55
Power consumption (kW)	7.5	17	32	54
Speed of motor rotation (rpm)	2900	2900	2900	2900
Voltage (V)	380	380	380	380
Heated volume (m ³)	Up to 350	Up to 700	Up to 1500	Up to 2400
Temperature of heat-carrying agent (C)	Up to 95	Up to 95	Up to 95	Up to 95
Heating efficiency (kcal/h)	7600	17000	35000	55700
Weight (control panel excluded) (kg)	130	250	400	550
Overall dimensions:Length (m)	1.3	1.3	1.5	1.8
Width (m)	0.5	0.8	0.8	0.8
Height (m)	1.3	1.8	1.9	1.7
Operating mode	Auto	Auto	Auto	Auto
Recommended water capacity (l)	150 - 200	400	650 - 700	1000
Price INCOTERMS FCA (USD)	4,310	6,400	7,827	8,750

Sales representative contact address:

Faraday Lab Ltd
 7 Lev Tolstoy str., St.-Petersburg, Russia, 197376.
 Tel/fax: (812) 3803844
 e-mail: office@faraday.ru,
<http://www.faraday.ru>

Our laboratory can demonstrates for the Customers the technology and we can organize test measurements of the efficiency for 5kW water vortex heat-generator.

The Secret of Antigravitation

Tim Ventura

<http://www.americanantigravity.com>
tventura6@comcast.net

Phone: 425-820-5675 Mobile: 425-260-4175

Dear Mr. Frolov,

I haven't been cc'ing you on my latest work as I should have -- I've been feeling a bit guilty about it, and thought I should write to ask you how the magazine is coming along, and if there are any papers that I can submit to you. I will attach my editorial piece "Secrets of Antigravity" - it is perhaps not the quality that I normally write, but more an opinion piece than my other work. Also, I have cc'd you on some interesting interviews I did with Russian Physicist Evgeny Podkletnov. Last week Dr. Eugene Podkletnov stunned the experimental AG community with the revelation that his Superconducting Force-Beam Generator was producing an output in excess of hundreds of pounds of pure gravitational force. We've just finished a follow-up interview with Podkletnov to learn more about the results that he's been getting, and we're amazed to say that the more we learn, the more impressive his experiments become: Podkletnov claims that the gravitational beam is generated by a 3 to 5 megavolt drop onto a 4-inch diameter superconductor, which is enclosed in a wrapped-solenoid to create a magnetic field around the apparatus. Pulses are powerful enough to punch through brick, concrete, and deform light-metals "like hitting it with a sledgehammer". The beam doesn't disappear rapidly with distance -- in fact, it's been measured at distances of up to 5 kilometers, and seems to penetrate all materials without a decrease in force. These are only a few of the details that he provides as we cover listener questions in this follow-up interview.

Original Interview (High-Quality) WinMedia Audio [1 mb]
<http://www.intalek.com/AV/Eugene-Podkletnov.wma>

Additional information is online at:
<http://www.americanantigravity.com/gravitywaves.shtml>

You can reach Podkletnov directly via email at:
epodkletnov@hotmail.com

Sincerely;

Tim Ventura
<http://www.americanantigravity.com>
tventura6@comcast.net

Community of Mind

A lot of what I do on a day to day basis consists of talking to experts in the field of gravity research – not only am I interested in learning more about the formal work that they've done, but I also like to hear about their thoughts and opinions as to "what makes gravity tick" – ie: the gut feelings that they have about what works and doesn't in the realm of antigravity research.

I've talked to a very diverse group of people working on many aspects of this technology – from Tom Bearden on the electronics and engineering side of things to Bob Lazar with relation to his supposed work on UFO systems for the government in the late 80's. I've talked to a diverse mixture of 'formal scientists', inventors, and other people with input on the subject and expertise to give them valuable input. What I've learned doesn't come from any one single source, but is instead a composite from a group of different people working towards a singular goal – they compose a "community of mind" that lends its expertise to moving the goal of antigravity research forward.

The Limits of Science

In the interest of fairness, I should state the Antigravity research really falls outside of conventional science. A lot of new people to AG research (including the 'general interest' segment of the public) have the impression that

we're opposed to conventional scientific establishment or government research efforts, but this isn't true – the research that's being done in the open-source community is really outside of the scope of 'big-science' and government-sponsored efforts, which is why it limits our ability to work with them on these projects.

There are two main theories that would seem to be the path for 'big science' in the formal community to tie in with Antigravity research – Quantum Theory and Relativity Theory. As I've stated in the past, the problem is that neither of these really provides the type of coverage that we need to move forward with a theory that promotes Antigravity as an extension of conventional science.

One of the main problems here is simply observational – thus far, devices that have produced an observable Antigravity effect have been few and far between, which makes it difficult for the conventional scientific community to really engage itself in learning about Antigravity and tying that knowledge back into conventional theory in terms of measurable theoretical models.

Quantum Theory

I saw a lecture on the internet by Dr. Richard Feynman last week in which he describes gravity as really falling outside of the confines of Quantum Theory due to the fact that it's so much weaker than the other forces that it isn't measurable on Quantum levels (ie: in single particle interactions). This limitation of the science has limited the ability of quantum-theory researchers to really include gravity research into their model of science, although some newer theorists are making great strides in this area.

One of the big proponents of an extension of quantum mechanics that would include a model for gravity (allowing gravity shielding) is Dr. Ning Li, formerly of the University of Huntsville. Her team, formerly part of the University but now working as an independent research group in a startup-company has been working with a method of creating what she calls "AC-Gravity" that is related to the rotating

superconductor experiments conducted by Eugene Podkletnov at Tampere, Finland in 1992.

Podkletnov noticed that smoke from a senior-researcher's pipe traveled in a column up towards the ceiling when his rotating superconductor apparatus was operated under certain conditions, and after careful work confirming this effect he attempted to publish a document suggesting that a "gravitational-shielding" effect was happening. Despite protest by the scientific community, Dr. Ning Li stepped forward nearly a year later to claim that she'd published a paper that had predicted his results nearly 2 years before he's obtained them.

Ning Li is now working in a secret-environment on her own experiments involving rotating superconductors, and from my research I've learned that she's getting results – in fact, in a carefully-written communique that I received from her in early 2003 she claimed that her team was able to produce over 11 kilowatts of "AC-Gravity" effect. This is the last that I've heard from her on the subject, and I suspect that her startup-company's financiers have restrained her from wanting publishing of her day-to-day research results.

Relativity Theory

Two particles traveling parallel to each other will not have an interaction between their magnetic fields, despite a conventional field-interaction between these particles if they aren't traveling on parallel paths. This was a section of a textbook on "relativity theory applied to magnetism" in a physics text that I own that helped me to realize that Relativity theory offers more leverage into gravity research than I'd originally thought. What it means is that magnetism, which is generally considered to be a fundamental force, is really nothing more than the interaction of the electrical fields of moving particles. Depending on how the particles are moving, this magnetic force may not even exist.

Decades after his death, the genius of Einstein's theory of Relativity continues to provide direction into gravity and Antigravity research. In another recently published article, the author mentions that the gravitational field of the sun

is slightly larger due to the heat (kinetic energy) of its constituent atoms. This is a consequence of Relativity theory, in this case related to the relative mass of a traveling particle and how it is related to the gravitational field that it creates around itself (more mass = larger displacement of the time-space continuum).

Biefeld-Brown Notes

I'd known about the Biefeld-Brown effect for about ten years before I became involved with building Lifters. This prior knowledge came from a 4 year period of researching levitation and antigravity technologies with Hovortech's Bill Butler, who was interested in Biefeld-Brown because of its potential to manipulate ions.

In short, the Biefeld-Brown effect uses the concept of 'asymmetrical capacitance' to create thrust, but its always been a difficult idea to sell because of a widespread opinion in the scientific community that it is nothing more than ion-wind. The Biefeld-Brown effect has defied categorization for the most part because it is so difficult to isolate from the associated ion-wind present in BB-Effect devices. In other words, these devices all use high-voltages, which inherently lead to the creation of ion-wind. While vacuum-chamber tests might serve to finally close the case on the BB-Effect, the chambers require a pressure of $10 \text{ E } -7$ torr to perform an adequate test – this pressure is exceedingly difficult to obtain without expensive lab equipment and a large-scale laboratory vacuum-chamber to test in.

Bill Butler had postulated that the Biefeld-Brown effect could be enhanced from the early charged-disk designs that Brown himself had used by containing the ions with a magnetic containment field. Although Brown's reported output didn't meet our needs for propulsion, an enhancement to increase the efficiency could be used fill a magnetic-plenum with charged particles, which should have theoretically created an air cushion below the devices containment field.

In reality, our experimentation didn't provide the results that we'd hoped it would, although

it did open some new doors for research that we'd previously neglected. Consequently, I'd written of Lifter technology as not being highly useful due to the same reasons that NASA tends to belittle it – not enough power or efficiency for useful propulsion.

Years went by, and I eventually became involved with Lifters in 2002 – these are small devices that utilize the Biefeld-Brown effect to actually lift off a surface and fly using only high-voltage electrical current. My first test flight was an interesting experience – because of my inexperience building Lifters and some older design requirements it barely stayed aloft, although the effect was spectacular enough to both keep me interested in the technology as well as attract the interest of the media and general public.

Lifters are Linear

Since the inception of the American Antigravity website in March 2002, I've had the opportunity to build and test nearly 200 Lifters, and found that the qualities of these devices that initially made them easy to experiment with also greatly limit the potential efficiencies of these devices for large-scale commercial applications.

In other words, Lifter technology is highly engineerable, which is positive in the sense that it makes designing and building these devices much less difficult than many other proposed Antigravity technologies. Although most of the calculations that I use are closer to estimates than precise working values, the result is that I generally have a good feel for when a Lifter will work or not – which is great when you take into consideration the demands of filming these devices to generate publicity for Antigravity research.

Unfortunately, the dark side of Lifter technology is that despite dramatic increases in efficiency, these devices generally speaking do not produce large amounts of thrust. The advances that have occurred since Brown's day are mostly incremental advances related to construction and precision – no major materials advances or giant leaps in technology have presented themselves.

Therefore, while increasing the size and power of a Lifter increases its overall thrust, the limitation on efficiency is still roughly comparable to that of a traditional helicopter. Efficiencies on that scale would be great for a company like Boeing or Lockheed to engineer, but aren't quite as useful for small, independent inventors who require much higher output-thrust ratios to create new prototypes.

High-Efficiency Antigravity Systems

At the same time that testing is repeatably producing grams (and sometimes pounds) of thrust from Lifter technology, there is another branch of research into Antigravity technology that seems to be producing much higher efficiencies from lower energy input.

Most members of the online Antigravity community on the Internet are familiar with the claims of inventors like Searl, Hamel, and more recently inventors like Marcus Hollingshead. These individuals are merely a few of the many who have stepped forward over the course of the 20th century to discuss experimental results that they claim far exceed those attainable with Lifter technology. In fact, the results that they've claimed are great enough the majority that it strains believability to listen to them describe these experiments, which also predictably never seem to work when a camera is rolling.

I conducted a correlation-study in early 2003 to analyze the claims of inventors like Searl in the hopes of learning more about what specific techniques or materials they might be using to produce thrust measurable in tons, rather than in grams.

The study, which was not as in-depth as I'd hoped it would be, showed a few common features. Firstly, these high-output experiments are much less repeatable and/or predictable than technologies like the Lifters are. While inventors like Searl claim to be able to build prototypes with highly consistent performance, there are a substantial number of inventors on the net attempting to either replicate or enhance designs like the Searl device who claim to have had no results at all. The reason for

many of these prototype failures is lack of construction expertise, poor materials, bad tolerances, and generally low-grade construction, but it would appear that several well-constructed prototypes have also failed.

Overall, there seems to be far more failure than success in this category of device, but this could also be due to the generally more precise requirements involved with building the advanced devices in comparison to the comparatively simple Biefeld-Brown technology. The Searl Effect generator, which Searl claims to have built and tested in the 1960's, actually requires at least several hundred thousand of today's dollars, and requires specialized fabrication due to the requirements of a complex magnetization process for its components.

Warping Time and Space

Unlike the very linear output of the Lifter technology, devices like the SEG or devices built by Hamel, Marcus, and others seem to produce an effect that is not directly related to their input energy. In other words, the effect almost seems to be an over-unity process, except that instead of generating electrical energy these devices produce a gravitational energy.

While producing twice the thrust in a Lifter requires approximately twice the input energy, the Marcus device uses only a few hundred watts of energy and is claimed by Marcus to create tons of propulsive force. Similarly, the SEG is reported to require only a spin on the central armature to spin the device up to speed, after which the device is supposed to not only maintain its speed with no input energy but also produce an Antigravity effect measurable in tons.

These results can also be extended to both Podkletnov and Ning Li's research, in that these researchers claim to have created a 'column' of Antigravity/AC-Gravity that changes the properties of all objects in its path. Thus, the amount of force actually exerted by these devices can very rapidly surpass the input energy.

Without having to resort to explanations

involving ‘over-unity’ processes, which are nearly akin to magic with relation to modern science, the most likely explanation for the incredible output of the SEG and related devices is that they’re actually somehow modifying the properties of time and space to create the operative propulsive force.

Dimensions & Bubbles

The geometry of time and space is just a tiny bit different on the Earth’s surface than it is in nearby space. The only real difference that we can obviously feel is that on Earth we experience gravity, whereas in space the same gravitational field will be much less. This is because as gravity’s pull tapers off with the square of the distance, the curvature of space-time tends to flatten out.

Picture time-space as being a flat sheet of rubber, and the Earth as being a heavy marble placed onto this flat rubber sheet. Naturally, the rubber would bend to accommodate the marble’s weight, and as a result anything else on the sheet that was near the bend would also experience a tendency to roll towards that marble.

Gravity works a lot like this rubber-sheet, and in the same way the geometry of the rubber is warped by the weight of the marble, the geometry of time-space is warped by the Earth’s mass. Hence, we live in a gravity well, where the Einsteinian curvature of the fabric of space provides the familiar pull that we experience as gravitational force.

Any point on the rubber-sheet surroun the vicinity of our marble has a certain curvature – an angle at which the rubber is curved. Similarly, any object sitting in the curved space surrounding the Earth will also be in a localized region of curved space. This curvature wouldn’t be noticeable to the object itself, but to an observer than can see both the flat part of the rubber sheet and the curved part the difference would resemble a ring around the marble (or a series of concentric rings of different angles, which seamlessly blend into each other as the rubber-sheet bends).

The idea that had occurred to me is that the

Searl Effect Generator and other devices of this type might actually be curving space around themselves, creating a region where the curvature of space is just a tiny-bit different than in the local environment. If the curvature is positive, the SEG would experience a greater attraction to the Earth than normal, but if the SEG was able to “uncurve” space to a certain degree then it may experience a generally reduced gravitational attraction to the Earth.

In other words, if you push your finger up from the bottom of the rubber sheet, the curvature will disappear in that region, and any objects rolling over that region will not experience the force that would otherwise pull them towards the marble.

Curved Space and Thrust

Assuming that these devices are able to uncurve Einsteinian space, or perhaps block the gravitons that are described in Quantum Mechanics, the expectation would then be that the SEG should sit motionless unless an upward force is applied. This isn’t what the reports about this device describe, however – the SEG can reportedly lift tons of weight, which would seem to either indicate that in addition to negating the device’s weight the SEG can also produce thrust, or alternatively that something else is causing an acceleration. The first explanation isn’t unreasonable, but the idea of an outside influence causing the acceleration and thrust would seem to be more in-line with conventional physics.

When you inflate a helium-balloon, it will tend to rise until it reaches a point in the atmosphere where the air is thin enough that the displacement weight of the balloon is the same as the external weight of the surrounding air (after which the balloon will cease to rise). What’s intensely interesting about this phenomenon is that the balloon itself isn’t doing any of the work – the outside environment performs the work of lifting the balloon. In fact, the energy put into lifting the balloon comes specifically from the Earth’s gravitational field, as it is that gravity that pushes the atmosphere down onto the planet and creates the 15-psi pressure that we normally live in.

Similarly, I believe that the energy that creates lift in the SEG, Marcus and Hamel devices comes not from the devices themselves but instead from the surrounding environment. In short, these devices create a curvature of time & space that's different than the curvature of the surrounding environment, and as a result the energy in the surrounding environment moves this 'bubble of curved space' until the curvature inside the bubble match that of the surrounding environment.

Thus, the function of the SEG-style of Antigravity device is simply to curve space, and in doing so, a very powerful propulsive effect emerges as a shadow force. This is an elegant solution in that not only does it seem to mesh with Relativity Theory, it also doesn't directly contradict known physics.

Editorial notes: This ideas was offeed also in article "Practical application of the time control theory", New Energy Technologies, 2001, #3. Alexander V. Frolov.

By removing the burden from the actual Antigravity device itself and placing it on the environment, it becomes much easier to visualize the tons of payload that these devices are reportedly capable of lifting. The gravitational field of the Earth is enormous, and a great deal of energy is bound up in this field – the energy can be harnessed to perform work simply by creating a local region of time-space that the Earth's environment naturally rejects.

Side-Effects

Not only does the explanation of the SEG as a device to curve space fit well with the reported payload capabilities that have been described, it also fits well with the reported 'side-effects' of operating these devices.

While the Lifter technology has some interesting side-effects while in operation, the high-output devices like the SEG, Marcus device, and others have an interesting array of effects that are described with remarkable similarity despite being observed by a variety of individuals who are usually not familiar with each other's research.

The side-effects from these devices appear to include things like inertial dampening inside the perimeter of the device's field while in operation, as well as changes in the air described as a "dark blurring" or "black cloud" that surrounds the device while in operation. Several other effects are also reported, but these two are some of the more notable effects.

Marcus experimented with placing a glass of water partially within the field of the device while it operates, which resulted in the water showing the field perimeter by having different water levels inside and outside the field's perimeter. Searl had reported that the inside of the SEG exhibited a constant ? G force in all directions that provides inertial dampening during operation.

The description of these devices as creating a localized curvature of time & space would support the notion of inertial dampening effects – after all, the properties of space-time are different than they are outside of the device's field-radius. The black-cloud would result from the bending of light (and/or Doppler shifting) that would be expected to occur as light passes through a heavily distorted region of time-space.

Creating the Effect

The correlation study seemed to show a common feature among nearly all of the devices reported to create large-scale AG propulsion – namely, the utilization in these devices of Rotating Magnetic Fields.

It's been said that Einstein based his study of Gravity on an examination of magnetism, and with only a few exceptions these forces definitely are similar in many respects. To begin with, both of these forces are 'field-only effects' – ie: magnetism only exists in the presence of moving electric fields, but doesn't exist if the fields are static (indicating that it is an aspect of electricity and time/space, and not a discrete force tied to the particle. Similarly, gravity is considered a consequence of the curvature of time/space and in the past has been called a "shadow force" on different occasions because it is very weak and difficult to interact with directly.

The physics textbook example that I cited in the first part of this treatise would seem to indicate that magnetism really doesn't exist without relative motion between particles – even if both of the particles are moving through space but yet remain motionless relative to each other. This suggests that magnetism is a bit like the wake in the ocean that a boat kicks up when it passes – the effect that the wake has on other boats is largely dependent on their orientation to it.

It is because of this similarity between magnetism and gravity that I believe that the SEG is able to create a “bubble” of localized space-time. The device possibly uses magnetic energy to create a ‘vortex’ in the background of the time-space continuum, and this vortex is then rejected from the local gravitational field by the surrounding environment.

Kinetic Motion

Another element that the Marcus device, SEG, and others have in common is kinetic-motion – more specifically in the form of rotation (the SEG uses rings and rollers, and the Marcus device utilizes circular rotating armatures, Hamel has off-center rotating magnets, etc...). Since electrons move through a wire when current flows, it took me a while to figure out what it was about the actual motion of the device itself that creates the AG effect. In other words, if electrons are moving through a wire while the device operates, why do they also require being physically moved through space by rotating part of the device itself?

Editorial notes: Prof. Butusov, St.Petersburg, proposed several methods of creation of the longitudinal waves. For example, mechanical rotation of the current circuit produce longitudinal waves of energy in vacuum. Properties of the waves are close to the antigravitation waves described by Tim Ventura. Small experimental device was built in Faraday Lab Ltd, St.Petersburg in 2002. The current was only a few Amperes and we did not detected some significant mass changes. But we detected some influence of this wave to radioactivity. We assume that the *Podkletnov's effect is related with the longitudinal waves conception.* Alexander V. Frolov

Interestingly, Tom Bearden provided the solution for me offhand one day when he mentioned that electrons typically only travel 8 to 10 inches per hour through copper wire when a normal current is flowing.

If magnetism is really a form of ‘wake’ in the fabric of space-time from moving electric fields, then it stands to reason that this magnetic-effect will be more pronounced if the electrons are moving more rapidly. After realizing how slowly electrons travel through wire in normal conduction, it stands to reason that whatever effect they produce would be very pronounced if they are moving much more rapidly.

Rotational Motion

The idea of rotation in these devices has been pointed out in the past, and one of the popular explanations for why these devices incorporate rotating components is that the rotation of the device creates a ‘symmetrical vortex’ in the fabric of time-space that concentrates whatever effect would otherwise happen into a smaller geometric area. An associated idea is that if the AG effect involves disturbing the fabric of time-space then without a continuous disruption in a small physical area the fabric of time-space will lapse back to normal.

The explanation above sounds more complicated than it really is – in practice, this would be the difference between something traveling rapidly through the ocean versus something traveling in a circular manner – in the first example the result would be a wake, and in the second a whirlpool would result.

There may be something more to this view than conventional physics would like to believe. Conventional explanations of centrifugal force are usually explained by being broken down into an object attempting to travel in a straight line and encountering a resistance, usually illustrated somewhat like a tether-ball traveling around a pole and being forced into a circular pattern by the tension of the rope.

However, there have been indications that more is going on with rotational force than meets the eye. Firstly, there was Erik Laithwaite's stunning presentation for the Royal Academy

of Sciences. After lugging a heavy 50-pound electric gyroscope into the auditorium, he then powered it up to normal rotational speed and easily hefted it above his head using only one hand.

A Relativity Thought Experiment

Imagine yourself in a space station, where the station is rotating enough to provide a steady 1-G acceleration against the interior walls of the station (much like the crew compartment of the spacecraft in the movie 2001: A Space Odyssey). While the traditional tether-ball explanation of centrifugal force would seem to explain the artificial-gravity with in Newtonian physics, it doesn't entirely work in Relativity Theory.

Let's take our theoretical space-station and move it into deep-space – perhaps a region of space so far removed from normal space that the stars aren't even visible. Looking outside the space-station, all that you would see is inky-blackness, and you couldn't see any part of the outside world with which to orient yourself.

Despite being in your space station in space so remote that you couldn't tell if it was rotating or in fact standing still with regard to the rest of the Universe, you would still feel the artificial gravity pushing you down onto the floor, presumably to the same degree of force that you'd experience at any other point in space.

Again, in Newtonian physics this isn't a problem, but in Relativity theory this is a real issue. One of the major tenets of relativity assumes that everything in the Universe is relative – that's why time moves more slowly in a traveling aircraft than on the Earth's surface, and why objects that fall into a black-hole can never reach its center (because at some point time stops for them due to the super-intense gravity).

In relativity theory, the only way that you can experience the centrifugal-force inside your space-station is if that space-station is rotating in relation to something else. This also applies here on Earth – if you hold your arms out and spin around in a circle, it not only appears that the world is spinning, but in a world based on pure relativity theory the world IS spinning.

However, if you try this experiment you'll astutely notice that while your arms experience a centrifugal force pushing them outward, the rest of the room you are inside does not. What does this mean?

The Third Observer – Mach's Principle

My interpretation of the experience of centrifugal force is that there must be a third-party that is the absolute standard that motion is compared against. Otherwise, how would it be possible that the person on the space station (or you in your room spinning around) experiences centrifugal force while the rest of the Universe does not?

What I am describing here is quite simple – it's a variant on Mach's principle, which states something like that kinetic energy is related to the sum total of all the gravitational energy in the Universe. Mach was obviously close to the point, and yet all of the Mach's principle devices that we've seen tested tend to fail miserably, so what gives?

Maybe Mach's principle has nothing to do with gravitational sum-totals and everything to do with the fabric of space-time. This fabric of space-time is the 3rd Observer that I mentioned above, as well as being the means of transfer for the actual 'energy' contained in kinetic energy.

Relativity theory has basically been proven through experimentation, and yet my elaboration on it would seem to undermine the theory. The only way around this is if the fabric of space-time is a 3rd Observer, but also is able to be manipulated under certain circumstances. In other words, you can bend, stretch, twist, or mangle the fabric of time and space, but be forewarned that in cases where something is actually moving through the fabric of space-time it functions as a 3rd Observer.

This explanation of time-space is a lot closer to a neo-ether theory than I would like it to be, but Einstein himself alluded to these with Relativity theory. In any case, this isn't meant to be the foundation of a new physics – merely a new perspective on time-space that fits with the strange effects of these Rotating Magnetic Field AG devices.

Heavy-Duty AG Design Specs

What I've been describing so far is basically a few different approaches to AG that involve Rotating Magnetic Fields. Once again, these typically consist of the mechanical rotation of electrical charges/currents through space. Depending on the level of detail that you want to drill down to, you can really summarize the majority of larger-scale ideas as belonging to this family of AG devices.

Paul Brown envisioned the SEG as working by a few different methods, and he wasn't sure which of these was correct (or the 'most correct' of his choices). One that caught my eye was his description of the SEG as being a Homopolar generator, in which the SEG itself was the stator and the Earth or the Earth's magnetic field was the amature.

This caught my eye after a conversation with Richard Hoagland, in which he suggested that rotation is the key to Antigravity but that conventional materials aren't able to spin fast enough to normally make the effect happen on a consistent basis. Hoagland is very familiar with the research of the late Bruce DePalma, who had reported some effects that resembled Antigravity effects when working with conventional rotating devices and especially in his research with Homopolar generators.

While I can't say for sure that Homopolar generator technology is a potential means for reducing the complexity of Rotating Magnetic Field AG-devices, it piques my curiosity because it involves both rotation and magnetic fields.

While this explanation may not apply to devices like the Hamel design or the Marcus device, it certainly does help to see where amateurs could have bad-luck creating AG if the SEG is really working as a new type of Homopolar generator.

Feedback Loops

This is moving out of the territory of the known and into the realm of things that are really just guesswork, but suppose for a moment that the key to the SEG is that it is a Homopolar Generator and also a magnetic energy storage device. In other words, a Homopolar generator works by rotating

a disk in a magnetic field, which in turn moves the electrons in the disk to create a current. One of the key factors to operation is the size of the magnetic field, which would increase with rotational speed in the SEG because the rollers themselves are Neodymium magnets.

In this view, the faster the SEG spins, the larger the magnetic field is, which means that more current is produced. Since the current being produced has a magnetic field of its own, it is entirely possible that the SEG can amplify the amount of power that it produces through a feedback loop.

Realistically, if the key to the SEG is a feedback loop, I don't think that this process is loss-less enough to be over-unity – however, it is possible that the overall field could be amplified to many times that of other devices based on a similar design. The key in this case would be in connecting the electrical output from the rim of the device to an input in the center of the device, as well as positioning the wiring-conduits to create a magnetic field that is additive with the one produced by default from the magnetic rollers.

The feedback-enhanced SEG would function as a battery for magnetism – storing an enormous magnetic field in a dynamic manner in the same way that a flywheel dynamically stores kinetic energy.

Micro-Rotation

Hoagland suggested another approach to the idea of Rotating Magnetic Field antigravity – in his view, DePalma was moving towards larger machines when the best substance to use might be a chunk of material in which the atoms could be spun synchronously. This could be achieved using a Nuclear Magnetic Resonance technique and might provide a solution for creating Antigravity on a mostly-electronic basis rather than the formerly-attempted kinetic-electric systems like the SEG.

Interestingly, if rotation has some intrinsic connection to the fabric of time-space that makes it especially useful in generating Antigravity effects, then Hoagland's idea might have more merit than larger-scale approaches to AG have in the past. The reason is that if both

rotation and linear motion include the concept of directional motion, however, in rotation the directional motion also as a rotational radius (for instance, the radius of each ring in an AG, or the radius of the armatures in the Marcus device). As this radius of rotation tightens, it's not unreasonable to expect that whatever interesting effects that rotation might have would be increased as a result (after all, if the rotational radius is zero then the object is simply traveling in a straight line).

Editorial notes: S. Poliakov and O. Poliakov demonstrated several methods of gravitation waves generation. One of the methods is precession of gyroscope and change of the gyroscope radius. It can be mechanical macro-gyroscope or micro-gyroscope in ferromagnetic material. Alexander V. Frolov

Imagine instead of an armature spinning with electrons being moved in a circle with a rotational diameter measurable in feet, condense the picture down to the scale of an individual atom, rotating with a radius so small that its not visibly measureable – this would have to disturb a larger portion of space in the local vicinity due to the increase rotational speed, although admittedly in a much smaller area.

Science rarely works with individual atoms, though, and in the case of an NMR technique for Antigravity its much easier to work with them in bulk. These atoms naturally have a spin associated with them, but normally the spins are not aligned – by using NMR to align the spins for specific elements, it would be interesting to see if there is an associated weight reduction involved.

Hoagland actually provided another facet to his idea of atomic-scale Antigravity, which was the concept of precession. He cited the Laithwaite experiments with gyroscopes as an example of precession being used for uni-directional force generation. This would be nearly as effective as gravitational-shielding (by comparison, Lifters are also generally considered to be uni-directional force generators).

Ordinarily, for every force, an equal an opposite force is created – this is why rockets use fuel, and aircraft need propellers to move the air. The

force that is generated on the propellant or surrounding air creates an opposite force that propels the rocket/aircraft forward as a result.

The rumor is that Laithwaite himself became interested in precession after watching a mechanic replace a gyroscope on an aircraft. The mechanic was pressed for time, and was carrying the still-spinning gyroscope down the steps of the aircraft from the cockpit to the runway below when he hit a step too hard and the gyroscope went into precession.

Precession occurs in rotating systems when an applied force manifests itself 90 degrees later in the direction of rotation from the position where the force was applied. In other words, this mechanic hits the step too hard and it sends a mechanical shock through the gyroscope, which in turn slams the technician's body & the gyroscope into the pavement below at high-speed.

Hoagland suggested that it might be possible to align atomic or possibly even molecular spin in a material and then find a way to send the entire block of substance into precession – which would then move in a direction with tremendous speed (the speed would probably depend on what percentage of the substance's atoms/molecules went into precession).

Conclusion

The information above is neither complete nor perfect – it's a best-guess approach to one particular method of Antigravity based on reported information available both in texts and on the web. There are a lot of factors that could invalidate this information, including misleading or falsified reports by inventors about what they've seen, and/or simple inaccuracies or unknowns in the underlying science.

Please note that while most of the time I take great pains to delineate speculation from known and validated science, in this article I tend to blur the line a fair amount. Also, don't leave with the impression that the ideas that I've cited in this document are the only paths of Antigravity research that are being pursued – these are in fact only a few of many approaches to AG -- I haven't covered the other approaches due simply to time constraints.

New Energy Technologies CD

All back issues of 2001 – 2004

We would like to suggest you to have a look at the list of articles that were published in our magazine during past years.

You may order this CD, containing PDF-files of all these issues (covers included and are in JPEG format).

Price is \$46 (with one printed current issue copy).

Visit our web site <http://www.faraday.ru> to pay online.

2001, №1 (1)

- An Experimental Investigation of the Physical Effects In a Dynamic Magnetic System. V.V. Roschin and S.M. Godin
- Torsion Technologies Are XXI Age Technologies. A. Akimov
- On New Energy and Political Authority, Alexander V. Frolov
- Effect of Many-Cavity Structures by Prof. Valery F. Zolotariov
- Quasi-Superconductive Technology, Prof. Dmitry S. Strebkov
- Water is the Basis of the Future Energetics. Phillip M. Kanarev
- Over-unity Patent of 1877 by Pavel Yablotchkov
- The Fundamentals of the New Principles of Motion, P. Sherbak
- Pondemotor Effect. Acad. Gennady F. Ignatyev.
- Experimental Gravitonics. S.M.Poliakov, O. S. Poliakov
- The Physical System of Artificial Biofield. A. Mishin
- Experimenting with Rate of Time. Vadim A. Chernobrov
- On Some Properties of Physical Time and Space. Albert I. Veinik
- Causal Mechanics. A review by Prof. Nickolay A. Kozyrev
- Spin (axion) Field Generator, Alexander Shpilman
- Sixth Revolution in Physics, Dr. Atsukovsky

2001, №2 (2)

- Kozyrev-Dirac Magnet-Monopole. Dr. Ivan M. Shakhparonov.
- The Hydro-Magnetic Dynamo by Acad. Oleg Gritskevitch
- Investigation of the Searl's Effect, S. M. Godin and V.V. Roshin
- Theoretical Basis of the Searl's Effect, by Dr. Rykov
- Hydrogen - helium Energy Dr. Oleg M. Kalinin
- A New Concept of Physical World, Dr. Nikolaev.
- The Main Principle of Etherodynamics, Dr. Mishin
- New Experimental Data from Dr. Mishin on the Ether and Antigravity Effects. The Discovery of The Center of The Universe.
- Capacitance Converter N.E.Zaev.
- Longitudinal Waves. Dr. Kirill P. Butusov.
- Work, Alexander V. Frolov
- Reactionless Propulsion and Active Force, A.V. Frolov
- Rythmodynamics of Amplitudeless fields, Y. N. Ivanov
- The DNA molecule and 4-D Holography, Alexander V. Frolov
- Gravity and Aether, I.Hayrullin.

2001, №3 (3)

- Time is a Mystery of the Universe, Dr. Lavrenty S. Shikhobalov,
- Experiments With a Time Machine. Vadim Chernobrov.
- Time is a Physical Substance, Dr. Kirill P. Butusov.
- Experimenting With Time, Prof. Velimir Abramovich.
- Practical Application of the Time Rate Control (TRC) Theory. Alexander V. Frolov, Russia
- Irving Langmuir and the Atomic Hydrogen. Dr. N. Moller, Greece
- Hydrogen Energy. Studennikov V.V., Kudymov G.I, Russia
- On Strange Effects Related to Rotating Magnetic Systems. M. Pitkanen, Finland
- Experiments with Lifters. Jean-Louis Naudin, France
- On the Great Constant 137.036. Dr. Anatoly Rykov, Russia
- Inertia Propulsion Drives. Boris D. Shukalov, Russia
- "Silver Cup" Antigravitational Spacecraft, E. Kovalyov, Latvia
- Gravity-inertial Mass. J.A. Asanbaeva, Republic Bashkiria
- Propulsion due to the Relativity Effect of the Inertia Force. Takuya Ishizaka, Japan
- Physical Properties of Axion Fields. Influence of an Axion Field on the Hardness of the Pearlitic Cast Iron. Alexander Shpilman,
- On the Significance of the Conical Shape of the Rotor of Clem's Generator. Alexander V. Frolov, Russia
- On History of the Cold Nuclear Fusion in Russia in 1960s. Review,

2002, №1 (4)

- On the Possibilities of Vortex Energy. News About Experiments by Acad. Gritskevitch O.V. and Lisniak S.A., Vladivostok, Russia.
- Tesla, "Time Control" and other aspects of Tesla's research, Prof. Velimir Abramovich, Rotterdam.
- Future Energy Technologies, Dr. Thomas Valone, USA.
- On the Question of Work Performed by an Electrostatic Field,
- New Methods of producing propulsion force. Eugene Sorokodum.
- The Antigravitational Wing, Ponomarev D.V. and Shibeko R.V.
- The Radio-telescope in Pulkovo Receives Signals Coming From the Center of the Universe, Dr. Alexandra A. Shpitalnaya and Dr. Alexander M. Mishin, St.Petersburg, Russia.
- The Inertialess Motion and Antigravity Are No More Secrets, Dr. Anatoly Rykov, Moscow, Russia.
- Inductive Conversion of Heat Energy to Electrical Energy, Experiments With Magnetic Materials Aimed At Getting Free Electric Energy From Magnetic Materials by Nikolay E. Zaev, Moscow, Russia.
- Tetra-space Coordinates, Josef Hasslberger, Italy.
- To the Question of Multipolarity, Alexander V. Frolov.
- Ball Lightning, Ivan Tshinarev, Tver, Russia
- The Problem of Electron and Physical Properties of Time Regarding Electronic Technologies of the 21st Century, Prof. Oleinik,
- Parametrical Generation of Alternating currents by N.D.Papaleksi, Alexander V.Frolov.
- Gerlovin's Theory of Activation.

2002, №2 (5)

- MEG Over-unity Electromagnetic Transformer by T.E.Bearden and Flux-machine, Alexander V. Frolov
- Fuelless Energy, N.E.Zaev.
- Symmetrization of Maxwell-Lorentz Equations. Experimental Methods Of Generating Longitudinal Waves in a Vacuum, K. Butusov
- Vortex Heat Generators, Dr. Eugene Sorokodum.
- Experimental Investigations Based on the Model of Electromagnetic Solitary Waves (solitons), Mikhail V. Smelov
- N.Kozyrev's Ideas Today, Dr. Shikhobalov.
- Kozyrev on the Possibility of Decreasing the Mass and Weight of a Body Under the Influence of Active Properties of Time.
- Longitudinal Thermomagnetic Effect, Dr. Alexander M. Mishin.
- An Introduction to Gravity, Low Price and Mart Gibson.
- A Physical Model of Experiments Carried Out by E. Podkletnov, V. Roshin and S.Godin, Anatoly Rykov
- Scalar Wars, T.E.Bearden
- The Problem of Electron and Superluminal Signals
- Gravitational Electrolysis

2002, №3 (6)

- Large-Scale Sakharov Condition, D. Noever and C.Bremner
- Matter As a Resonance Longitudinal Wave Process, A.V. Frolov
- The Physical Principles of The Time Machine, A.V. Frolov
- The Time Machine Project by Alexander V. Frolov
- Kozyrev-Dirak Radiation, Ivan M. Shakhparonov
- Electrical-Vortex Non-Solenoidal Fields, S. Alemanov
- Physical Mechanism of Low-Energy Nuclear Reactions, V.Oleinik, Yu. Arepjev
- The Evolution of the Lifter Technology, T. Ventura
- Reality and Consciousness in Education and Activity, A.Smirmov
- On the Influence of Time on Matter, A. Belyaeva
- Ageing-Preventive Features of Bio-Heater, A. Belyaeva
- A Technical Report on Belyaeva's Heater, Sh. Mavlyandekov
- Fundamental Properties of the Aether, A. Mishin

- The Influence of the Magnetic Blow-Wave Field I. Shakhparanov.
 - Nikola Tesla and Instantaneous Electric Communication, V. Korobeynikov
 - A Unified Theory of Gravity, I. Kuldoshin
 - New Sources of Energy from the Point of View of the Unitary Quantum Theory, L.G. Sapogin, Yu.A. Ryabov, V.V. Graboshnikov
 - Antigravity Force and the Antigravity of Matter. A. K. Gaponov
 - A Capacitor, Which Possesses Energy of an Atomic Bomb (Review of Gaponov's research)
- 2002, №4 (7)**
- Gravitonics, Spartak M. Poliakov, Oleg S. Poliakov
 - Experimental Research on a Gravity Propulsion System.
 - The Beamship Technology, Russell Anderson
 - Commercial Antigravity, Tim Ventura
 - Action Without Reaction. Yuri N. Ivanov
 - New Possibilities of Vortex El. Devices, Stanislav A. Lisnyak
 - An Investigation of Electric Energy Transmission Processes in non-Metallic Conducting Channels, D.S. Strebkov, A.I. Nekrasov, S.V. Avraamenko
 - Microcosm – Universe - Life, A.G. Shlienov, E.L. Petrov
 - Hypothesis of a Theory of Everything, Jack P. Gibson
 - The Charge and Mass of a Photon, Dzabrail Kh. Baziev
 - The Homopolar Motor: A True Relativistic Engine, Jorge Guala-Valverde, Pedro Mazzoni, Ricardo Achilles
 - Weight Reductions Caused by Bucking-Field Permanent Magnets, William C. Simpson
 - Nuclear Waste Decontamination Technologies, M. Poringa
 - Experimental Investigations of the Change in the Radioactive Isotope Half-Value Period in the Local Volume of Cause-Effect Relations, Igor A. Melnik
 - Tilley Electric Vehicle
 - The Problem of Time: Force as the Cause of Change in the Course of Time, Valentin P. Oleinik
 - Time and its Physical Relationships, Andrew Michrowski
 - Time as a Phenomenon of the Expanding Universe, Shulman
 - Experiments on Thermo-Gravitation. Review
- 2002, №5 (8)**
- Frolov's Asymmetrical Capacitors
 - The Electrokinetic Apparatus by T.T. Brown
 - Nikola Tesla's Later Energy Generator Designs, Oliver Nicholson
 - High-Efficiency Electrolysis, Alexander V. Frolov
 - New Results of Development and Testing of a Single-Wire Electric Power System, Prof. Dmitry S. Strebkov, Eng. Stanislav V. Avramenko, Dr. Aleksey I. Nekrasov, Eng. Oleg A. Roschin
 - Shauburger's Engine? by Eugene Arsentyev
 - The De Aquino ELF Gravitational Shield, Tim Ventura
 - Ferrites and Generation Of Free Energy by Means of Ferromagnetics, Nikolay E. ZaeV
 - Key Concepts for the Conversion and Control of Gravitational Energy, Glenn M. Roberts
 - Analysis of the Additional Energy Formation Processes in Vortices and Vortex Heat Generators, Dr. Alexey M. Savchenko
 - Kuldoshin's Transformer, Review
 - Disappearance of Inertia Force Mechanical Resonances and Free Energy Work, Arkady P. Kuligin
 - The F-Machine, Vyacheslav I. Boryak
 - The LUTEC Magnet Motor-Generator
 - How to Build Electrical Solid-State Over-Unity Devices, William Alek
 - The "Time" Seminar Held in Moscow State University
 - A Vortex DC Motor
 - Valerian Sobolev's Discovery. Review
 - Review on the Tilley Electric Car, E. Mallove
- 2002, №6 (9)**
- Some Experimental News, A.V. Frolov
 - On the Possibility of Controlling the Course of Time, V.P. Oleinik, Yu.C. Borimsky, Yu.D. Arepjev
 - Spontaneous Polarization of some Glasses and Direct Current as an Inexhaustible Energy Source, L.G. Sapogin, Yu.A. Ryabov
 - New Fuelless Space Power Engineering, V.D. Dudyshev
 - Electrodynamical Explanation of Ball Lightning, S.B. Alemanov
 - The Nature of Torsion Fields, V.V. Uvarov
 - Matter, Space and Time in Aether Field Concept, A.M. Mishin
 - Reidar Finsrud's Perpetual Mobile in Norway, John Pasley
 - Physical Quantum Vacuum is a Source of Electromagnetic Energy, P.M. Shalyapin
 - Instantaneous Electrical Communication, VI. Korobeynikov
 - Investigation of a Single-Wire Electric Power System, D.S. Strebkov, S.V. Avramenko, A.I. Nekrasov, O. A. Roschin
 - Fuelless Monothermic Engine (Invention by Y. Volodko)
 - On Viktor S. Grebennikov's Discoveries. Review
 - Experimental Study of Properties of Time. Review
 - Bedini Generator, David Mason
 - Article Update for An Introduction to Gravity, Lew P. Price
 - The CIP Engine Principle, Robert L. Cook
 - The Energy Machine of Joseph Newman, Michael Williamson
 - What is the RQM Technology? Review
 - Experimental Data on Time Control by Acad. A.I. Veinik
 - The Space Power Generator by P. Tewari. Review
- 2003, №1 (10)**
- Testatika. A Review of a Well-Known Electrostatic System.
 - Cold Fusion by Plasma Electrolysis of Water. Ph.M. Kanarev.
 - What A Cold Fusion Is? E. Storms
 - Technical Introduction to LENR-CANR (Low Energy Nuclear Reactions). E. Storms
 - It all Started in 1989... (History of Cold Fusion Development). P. Hagelstein
 - A Science Tutorial (Cold fusion). T. Chubb
 - LENR (Low Energy Nuclear Reactions) Experiments.
 - On Electrogravitation. A.V. Leshenko
 - Avalanche-drive Propulsion Device. M.L. Filho
 - Hydrogen-Powered Vehicles. P. Behr, G. Schneider
 - Unusual Permanent Magnet Motors. T. Valone
 - Hydrogen Energetics. A. Pashova
 - On the Longitudinal Electromagnetic Waves. A.V. Frolov
 - Space and Terrestrial Transportation. T.C. Loder
 - Commercialising the "Searl Effect".
 - Interesting Publications of the Last Year.
 - "Lifter" Project
 - New Electric Fire Technology. V.D. Dudyshev
 - New Effect of "Cold" Evaporation. V.D. Dudyshev
 - Conceptual Hurdles to New Millennium Physics. D. Reed
 - Resonant Phenomena in AC Current Circuit. A.V. Frolov
- 2003, №2 (11)**
- Minato Wheel. E. Vogels (Sweden)
 - Mechanism of Drive-Free motion. S.A. Gerasimov (Russia)
 - Production of Ball Lightning. Report by A. Pashova (Russia)
 - Electric Discharge. G.D. Shabanov, O.M. Zhrebtsov (Russia)
 - Free Energy. A.V. Frolov (Russia)
 - Some General Properties of Matter and Energy Sources. E.D. Sorokodum (Russia)
 - Commercial Exploration of Space. Review by O. Leontyeva.
 - Prospects of Hydrogen Energetics. Ph.M. Kanarev.
 - Heater Producing Healthy Effect. A.L. Belyaeva
 - Inertial Propulsion Device. V.E. Senkevich (Russia)
 - Unlimited Accelerated Nonreactive Motion. Review.
 - Revolutionary Current. S.K. Baliyan (India)
 - Tilley Electric Vehicle. Review.
 - Trends in the Application of Motor-Generators. A. Akau
 - Electric Vehicle in Russia. Review by A. Pashova (Russia)
 - The Richard Clem Motor and the Conical Pump. R. Koontz.
 - Spontaneous Flow Heat Pump. J.-L. Brochet (France)
 - Registration of Gravitational Waves. V.N. Petrov (Russia)
 - High-Energy Hyper-Low-Frequency Electric Field. Yu.V. Ivanko.
 - To the Question of Work Performed by the Electrostatic Field. A.V. Frolov (Russia)
- 2003, №3 (12)**
- Designing of a Time Machines. Vadim A. Chernobrov (Russia)
 - Control of Temporal Parameters of Physical Processes. A. Frolov.
 - Etherodynamics as a New Field of Physics. V. Atsukovsky.
 - Electromagnetic Gravitational Interaction, V. Ya. Kosyev
 - Medium For Existing of Matter in Nature. Anatoly V. Rykov.
 - Adams Motor. Sergey S. Abramov (Russia).
 - Field Transformation in the Model of Extended Space. Dmitry Yu. Tsipenyuk (Russia).
 - Joe Flynn's Parallel Path Magnetic Technology. Tim Harwood.
 - Flux-machine and Its Analogues. Review
 - Russian Patents on Alternative Energetics.
 - Gravitational Spaceships. Gregory R. Uspensky (Russia)
 - On Velocity Of Drive-Free Motion. S.A. Gerasimov
 - Electromagnetic Self-Action. S.A. Gerasimov, A.V. Volos
 - Uranium Photoaccumulator. Anton I. Yegorov (Russia)
 - Teleportation. Alla V. Pashova (Russia)

- "Mass Defect" in Home Conditions. Prokofy V. Sherbak.
- Aether as Unified Field. Alexander M. Mishin (Russia)
- Global Energy. Philip M. Kanarev (Russia)
- Fusion Processes Of Molecules Of Oxygen, Hydrogen And Water. Philip M. Kanarev (Russia)
- Plasma Energy Power Generation. Bruce A. Perreault.
- The Marcus Device Controversy. Tim Ventura (USA)
- Systems of conversion of thermal energy to mechanical one. Review

2003, №4 (13)

- Single-Wire And Wireless Electric Power Transmission. N.V. Kosinov and others (Ukraine)
- The possibility of almost complete transformation of thermal energy into mechanical one. S.N. Doonaevsky (Russia)
- Inventor Club. Review. Vector Propulsion Engine (Electromagnetic Version). A. S. Tukanov (Russia)
- Inertial Dynamic Generator. S.N. Schmidt (Russia)
- Latent Potential Energy of Electrical Field. V.D. Dudyshev
- Energy from Air. M.P. Beshok (Russia)
- A Parade of Gravitational Aircrafts. V.A. Chernobrov • Energy from vacuum. Review
- Meeting of Nobel Prize Laureates in Saint Petersburg
- Perpetual Motor With Magnetic Control Elements.
- Who Needs A Controlled Thermonuclear Fusion? I.B. Kalugin
- Fuel cells. Edwin Cartlidge (USA)
- Free Energy. Thomas F. Valone (USA)
- Secrets of Nicola Tesla's Experiments. S.S. Makukhin
- Alternative Cold. Review
- High-Efficiency Technology of Magnetic Cooling. E.N. Tishina (Russia)
- Interference Disc Electric Generator. Alan L. Francoeur (an announcement of the future article) (Canada)
- Howard Johnson and his Motor. Review
- Bogomolov's Centrifugal Generator. V.I. Bogomolov
- Magnetic Motor. A.V. Vydrin (Russia)
- "Omega" Anomalous Hydrogen Reactor
- Gravitational Shielding. Harald Chmela (Austria)
- The Concept of Magnetic Gas

2003, №5-6 (14-15)

- Novozhilov's Motor, Y. Novozhilov, Russia
- Self-Action in the case of Magnetic Rotation, S. Gerasimov and others, Russia
- Capillary Motor, I. Elshansky, Russia
- Gravity-Heat Energy System, V. Sukhanov, Russia
- Modern Perpetual Mobile, Review
- Free Energy and Antigravitation, (Spin Wave Lasers), Ines Espinosa, USA
- Mechanical Analogies, Y. Ivanko, Ukraina
- Cell of Fine-Plasma Electrolyse, Ph. Kanarev, Russia
- Smith's Generator, Review.
- Strategy of Over-unity Devices Marketing, R. Wood, USA
- Hutchison Effect, Mark Solis, USA
- Heat Energy Conversion by Means of Non-Linear Dielectric, A Ries and others, Brasil
- Gates' Motor, A. Akau, USA
- "Cold Electricity", A.Akau, USA
- Gravity Conversion Rotary Device
- Torsion Technologies, China
- News
- Antigravitation, B.Smith, USA
- Electric Levitation, MacLeod, Canada
- Perpetual Mobile, V. Likhatchev, Russia
- Interference Generator, A.Francoeur, Canada
- A New Paradigm of Time, D. Reed, USA
- On the Rotating Permanent Magnet System, A.Frolov.
- Inventor's Week, USA
- Patents on Inertial Propulsion Systems
- Bogomolov's Experiment With Spring Drive, Russia
- History of Perpetual Mobile
- Tesla Energy Science Conference, USA
- Perendev's Company, Review
- Internet Pages About Free Energy
- Matveev's Electrical Generator, Russia

- Perpetuum Motor With Magnets, France
- The most interesting of 2003
- Hydrogen Power Engineering, Review
- News on Hydrogen Fuel Cells
- Electric Discharge as Part of the Over-Unity Device.

2004, №1 (16)

- Torsion Technologies Are Technologies of The XXIst Century, A.E.Akimov, Russia
- The Antigravitational Platform, Review
- Potapov's Vortex Heat Generator, Yu.S.Potapov
- Fuelless Air Combustion, Alexander V.Frolov
- A Free Energy Generator, Zoltan Losonc, Hungary
- Society for Development of Free Energy Technologies (GFE, Germany)
- The "Confined B-field" Homopolar Dynamotor, J. Guala-Valverde, and Pedro Mazzoni, Argentina
- A Hydroelectric Heat Generator, F.M.Kanarev, Russia
- Conversion of Environmental Energy, B.M.Kondrashov, Russia
- The World of Free Energy, Peter Lindemann, USA
- The LUTEC Free Energy Generator, Australia
- Pulsed Direct Current for Light Circuits, Gary Magratten, USA
- Patent Applications on Thermo-Gravitation, Russia
- An Electrogravitational Engine
- "BREEZE 5000" Wind Energy Installation, T.A.Pungas, Russia
- Silicon-Based Power Engineering
- A Method of Extraction (Restitution) of Energy, V.F.Markelov, Russia
- Asymmetric Capacitors, Alexander V.Frolov
- Force on An Asymmetric Capacitor, Chris Fazi, USA
- The Working Principle of Frolov's T-Capacitor, Zoltan Losonc, Hungary
- A Precession Free Energy Generator, V.I.Bogomolov
- On The Way To A New Astronautics, A.V.Perfiliev, Russia
- An Energy Converter, Review
- What Ever Happened To Black Light Power? Patrick Bailey, USA

2004, №2 (17)

- The Techno Maestro's Amazing Machine Kohey Minato.
- A Thermomagnetic Engine, Yu. Novozilov, Russia
- A System of Effective Energy Conversion, Yu. Novozilov, • News from Prof. Kanarev, Russia
- U.S. Will Give Cold Fusion Second Look, Kenneth Chang.
- Life After The Oil Crash, M. Savinar, USA
- Movement From Nothing, P.Ball, USA
- Vortex Heat Generators, Review by N. Ovtcharenko
- A Thermogenerator And A Liquid-Heating Device, R. Mustafaev
- Energy Generator, G.N.Ryabusov, Russia
- Ethanol For The Hydrogen Economy, S. Clifford, USA
- To The Stars, W. Scott, USA
- Many Faces of the Electron, A.Akau, USA
- Vortex Heat Generators by Yu. S. Potapov, A. Frolov.
- Tesla & Schauburger Technologies, F. Germano, USA
- The Nature Of The Electron, L.Price, USA
- The Gravity Conversion Device
- A Device For Converting Potential Energy, A.I.Doronkin, • A Manual for Designing Ether-based Engines, G.Ivanov, • How To Calculate the Efficiency, V.I.Korobeinikov, Russia
- Commercializing The "Searl Effect", Review
- Wallace Minto's Weeel
- Original Ideas of William R. Lyne, Notes From Editor
- The Magnetic Field Rotator, A.Sidorovitch
- Newman's Motor
- Road To Hydrogen, Press Release
- The Waterjet Turbine, Edward Neurohr, Germany
- The Homopolar Transfer of the Mass Charge, V. Dudishev, • Electron-Positron
- Is A Revolution In The Fundamental Sciences Possible? V.Andrus, Ukraine
- In Memory Of Eugene Mallove
- Esoterica As A Catalyst For A New Era In Physics, D.Reed,